

Pitman Arm: Service and Repair

Sector Shaft Arm Drag Link



Special Tool(s)

Removal and Installation

1. If equipped, remove the steering linkage damper.
2. Remove the RH outer tie-rod end cotter pin and nut.
 - ^ Discard the cotter pin.
 - ^ To install, tighten to **95 Nm (70 ft. lbs.)**.

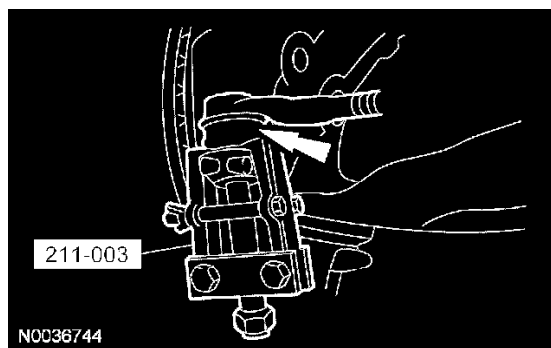

3. Using the special tool, separate the RH outer tie-rod end from the wheel spindle.
4. Remove the inner tie-rod end cotter pin and nut.
 - ^ Discard the cotter pin.
 - ^ To install, tighten to **95 Nm (70 ft. lbs.)**.

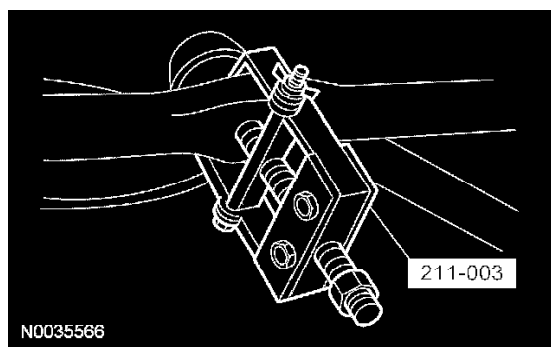

5. Using the special tool, separate the inner tie-rod end from the sector shaft arm drag link.

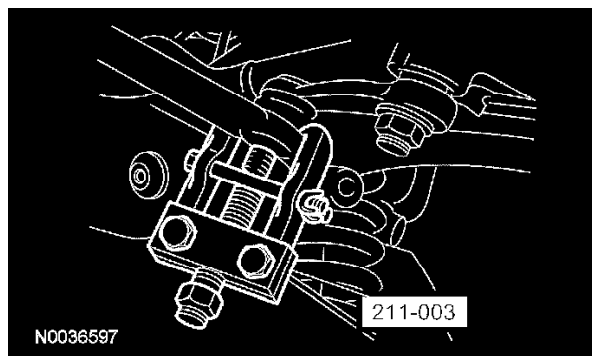

6. Using the special tool, separate the sector shaft arm drag link from the sector shaft arm and remove the drag link.
7. **NOTE:** For reference during installation, count and record the number of turns required to separate the outer tie-rod end and adjusting sleeve from the sector shaft arm drag link.

Loosen the RH outer tie-rod adjusting sleeve nut and separate the outer tie-rod end and adjusting sleeve from the sector shaft arm drag link.

^ To install, tighten to **49 Nm (36 ft. lbs.)**.

8. If equipped, remove the 4 steering linkage damper U-bolt nuts, the 2 U-bolts and the bracket.

NOTE: When tightened, the tie-rod adjusting sleeve bolts, nuts and clamps must be positioned within a limit of **45 degrees (±)**. The threaded ends of the LH adjusting sleeve bolts point towards the front of the vehicle. The threaded ends of the RH adjusting sleeve bolts point rearward.

NOTE: When installing the steering linkage damper bracket, make sure the bracket is properly positioned on the sector shaft arm drag link before tightening the U-bolt nuts.

To install, reverse the removal procedure.

10. Check and, if necessary, align the front end.