

Computers and Control Systems: Pinpoint Tests

Pinpoint Test Schematic

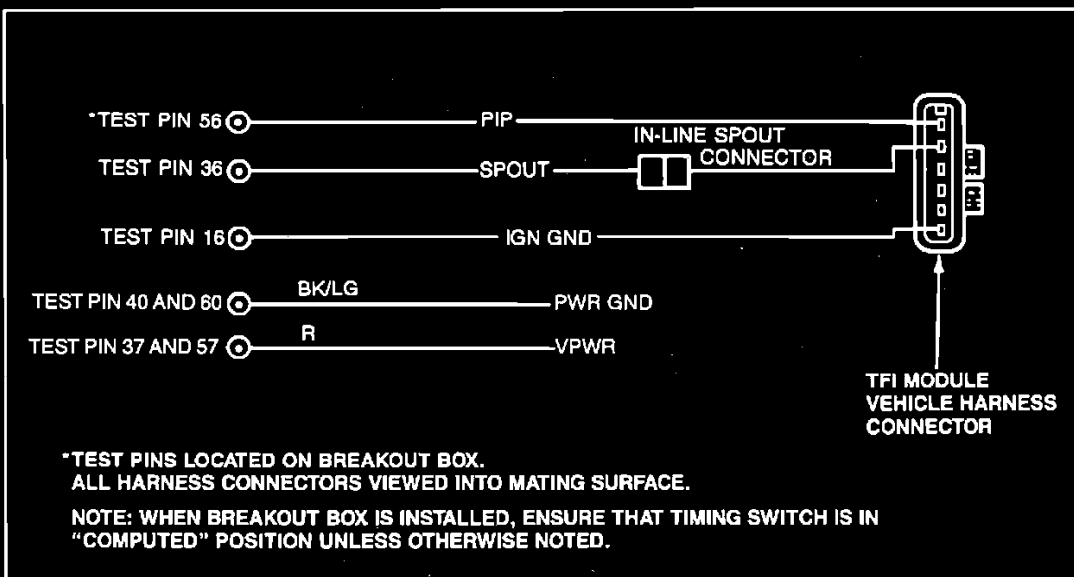

Test Pin 16	IGN GND
Application	Wire Color
5.8L F-Series	O
All Others	O/R

Test Pin 36	SPOUT
Application	Wire Color
2.9L Ranger 4.9L F-Series 5.0L F-Series 5.8L F-Series	PK
All Others	Y/LG

Test Pin 56	PIP
Application	Wire Color
2.9L Ranger 4.9L F-Series 5.0L F-Series 5.8L F-Series	GY/O
All Others	DB

EEC-IV Pinpoint Test

Note

You should enter this Pinpoint Test only when Quick Test has been successfully completed and the engine is still a no start or when directed here from IGNITION SYSTEMS.

Remember

To prevent the replacement of good components, be aware that the following non-EEC areas may be at fault:

- Fuel: quantity and quality
- Ignition: general condition, moisture, cracks, damage, etc.
- Engine: internal, valves, timing belt, camshaft
- Starter and battery circuit
- Dual hall sensor
- TFI or DIS module
- Distributor
- Camshaft sensor (CID)
- Single hall crankshaft sensor (PIP)
- Ignition coil or DIS coil
- Engine Governor Module

This Pinpoint Test is intended to diagnose only the following:

- Spark (as related to EEC-IV)
- Harness circuits: PIP, SPOUT, IGN GND, VPWR
- Processor assembly (-12A650-)

NOTE: This pinpoint test is intended to diagnose TFI ignition systems, Closed Bowl Distributor (CBD) with remote mount TFI systems and Distributorless Ignition Systems (DIS).

To identify your system, please refer to the application chart below.

IGNITION SYSTEM APPLICATION CHART:

Ignition Connector	Vehicle Application
DIS Connector (Pins 1-6 and 7-12)	2.3L EFI Truck,
Distributor Hall Connector and TFI Connector (used for closed bowl distributor, remote mount TFI systems)	3.0L Aerostar/Ranger, 7.5L Truck
TFI Connector	All Others



EEC-IV Pinpoint Test

WARNING

STOP THIS TEST AT THE FIRST SIGN OF A FUEL LEAK AND SERVICE AS REQUIRED.

CAUTION

No open flame — No smoking during fuel delivery checks.

TEST STEP		RESULT	ACTION TO TAKE
A1	ATTEMPT TO CRANK ENGINE		
<p>NOTE: For DIS vehicles, if continuous memory code 19/214 is present, refer to Quick Test Step A10 or A11 for proper direction.</p> <ul style="list-style-type: none"> Does engine crank? 		<p>Yes</p> <p>No</p>	<p>GO to A2</p> <p>GO to STARTING AND CHARGING SYSTEM</p>
A2	CHECK FOR VREF AT THROTTLE POSITION SENSOR		
<p>NOTE: Verify fuel pump inertia switch is set (button pushed in). Refer to FUEL SYSTEMS/COMPONENT LOCATIONS for location.</p> <ul style="list-style-type: none"> Key off. Disconnect TP sensor. Key on, engine off. Measure voltage between VREF circuit and SIG RTN circuit at the TP sensor vehicle harness connector. Is voltage between 4.0 volts and 6.0 volts? 		<p>Yes</p> <p>No</p>	<p>RECONNECT TP sensor. GO to A3.</p> <p>GO to Pinpoint Test C, Step C1.</p>
<p>SIG RTN ————</p> <p>VREF ————</p> <p>TP SIGNAL ————</p>  <p>ALTERNATE THROTTLE POSITION SENSOR VEHICLE HARNESS CONNECTOR</p>			
<p>SIG RTN ————</p> <p>TP ————</p> <p>VREF ————</p>  <p>THROTTLE POSITION (TP) SENSOR VEHICLE HARNESS CONNECTOR</p>			

EEC-IV Pinpoint Test

TEST STEP		RESULT	ACTION TO TAKE
A3	CHECK FOR SPARK AT PLUGS		
	<ul style="list-style-type: none"> • Disconnect the spark plug wire to any accessible cylinder (on 2.3L DIS truck disconnect exhaust side spark plug only.) • Connect spark tester between spark plug wire and engine ground. • Crank engine and check for spark. • Reconnect the spark plug wire to the spark plug. • Was spark present and consistent? 	Yes No	GO to A12 . For DIS vehicles: GO to A5 . For all others: GO to A4 .
A4	CHECK FOR SPARK AT COIL		
	<ul style="list-style-type: none"> • Remove high tension coil wire from distributor and install spark tester. • Check for spark while cranking. • Reconnect high tension coil wire to distributor. • Was spark present during crank? 	Yes No	Go to IGNITION SYSTEM for distributor cap, rotor, and wire troubleshooting. GO to A5 .
A5	CHECK CONTINUITY OF IGN GND CIRCUIT		
	<ul style="list-style-type: none"> • Key off. • Disconnect processor 60 pin connector. Inspect for damaged or pushed out pins, corrosion, loose wires, etc. Service as necessary. • Install breakout box, leave processor disconnected. For vehicles with TFI only: — Disconnect TFI module connector. For vehicles with DIS: — Disconnect DIS module (Pins 7-12). For vehicles with distributor hall and TFI: — Disconnect distributor hall connector.	Yes No	GO to A6 . SERVICE open circuit. REMOVE breakout box. RECONNECT all components. RERUN Quick Test. (Refer to TESTING PROCEDURES/QUICK TEST AND DIAGNOSTIC AIDS/ DETAILED QUICK TEST PROCEDURES/KEY ON ENGINE OFF SELF TEST for quick test procedures).
A6	ISOLATION OF PROBLEM TO SPOUT CIRCUIT		
	<ul style="list-style-type: none"> • Reconnect TFI module, DIS module (pins 7-12) reconnect distributor hall connector, as applicable. • Breakout box installed. • Connect processor to breakout box. • Timing switch to "Dist" position on breakout box. • Attempt to start vehicle. • Does the vehicle start? 	Yes No	Timing switch to "Computed" position on breakout box. GO to A10 . GO to A7 .

EEC-IV Pinpoint Test

TEST STEP		RESULT	ACTION TO TAKE
A7	CHECK SPOUT SIGNAL		
<ul style="list-style-type: none"> • Key on, engine off. • Breakout box installed, processor connected. • Timing switch to "DIST" position on breakout box. • Measure voltage between Test Pin 36 at the breakout box and battery negative post during crank. • Is voltage between 3.0 and 6.0 volts? 		Yes	▶ EEC system OK. REMOVE breakout box. RECONNECT all components. Go to IGNITION SYSTEM for TFI or DIS troubleshooting.
		No	▶ PLACE timing switch to "Computed" position and GO to A8 .
A8	CHECK SPOUT AND PIP CIRCUITS FOR SHORTS TO POWER AND GROUND		
<ul style="list-style-type: none"> • Key off. • Breakout box installed. • Disconnect processor. <p>For 3.0L SHO:</p> <ul style="list-style-type: none"> — Disconnect crankshaft sensor. — Disconnect DIS module (pins 1-6) connector. <p>For 2.3L Truck</p> <ul style="list-style-type: none"> — Disconnect DIS module (pins 1-6) connector. <p>For vehicles with "Integral" or "Pigtail" distributor hall:</p> <ul style="list-style-type: none"> — Disconnect distributor hall and TFI module. <p>For all others:</p> <ul style="list-style-type: none"> — Disconnect TFI module. <ul style="list-style-type: none"> • Measure resistance between Test Pin 36 (SPOUT) and Test Pins 16, 20, 40, 46, 60 (short to GROUND), 26, 37, 57 (short to POWER) and 56 (short to PIP) at the breakout box. • Measure resistance between Test Pin 56 (PIP) and Test Pins 16, 20, 40, 46, 60 (short to GROUND), 26, 37, 57 (short to POWER). • Is each resistance greater than 10,000 ohms? 		Yes	▶ GO to A9 .
		No	▶ SERVICE short circuit. REMOVE breakout box. RECONNECT all components. RERUN Quick Test. If vehicle does not start, GO to A9 .









EEC-IV Pinpoint Test

TEST STEP	RESULT	ACTION TO TAKE
<p>A9 ISOLATE SHORT(S) IN PROCESSOR</p> <ul style="list-style-type: none"> • Key off. • Breakout box installed. • Reconnect processor to breakout box. <p>For 3.0L SHO:</p> <ul style="list-style-type: none"> — Disconnect crankshaft sensor. — Disconnect DIS module (pins 1-6) connector. <p>For 2.3L Truck</p> <ul style="list-style-type: none"> — Disconnect DIS module (pins 1-6) connector. <p>For vehicles with "Integral" or "Pigtail" distributor hall:</p> <ul style="list-style-type: none"> — Disconnect distributor hall and TFI module. <p>For all others:</p> <ul style="list-style-type: none"> — Disconnect TFI module. <ul style="list-style-type: none"> • Measure resistance between Test Pin 36 (SPOUT) and Test Pins 37 and 57 (short to POWER) also, Test Pins 40 and 60 (short to GROUND) at the breakout box. • Measure resistance between Test Pin 56 (PIP) and Test Pins 37 and 57 (short to POWER). Also Test Pins 40 and 60 (short to GROUND) at the breakout box. • Is each resistance greater than 500 ohms? 	<p>Yes</p> <p>No</p>	<p>RECONNECT all components. GO to A10 .</p> <p>REPLACE processor. REMOVE breakout box. RECONNECT all components. RERUN Quick Test.</p>
<p>A10 CHECK PIP SIGNAL</p> <ul style="list-style-type: none"> • Key off. • Breakout box installed, processor connected. • Measure voltage between Test Pin 56 and Test Pin 16 at the breakout box. (For 2.3L DIS truck and Mustang, switch timing switch to "Dist" position on breakout box.) • Crank engine, record reading. • Is voltage between 3.0 and 7.0 volts? 	<p>Yes</p> <p>No</p>	<p>REPLACE processor. REMOVE breakout box. RECONNECT all components. RERUN Quick Test.</p> <p>GO to A11 (for 2.3L DIS truck switch timing switch to "Computed" position on breakout box.)</p>

EEC-IV Pinpoint Test

TEST STEP		RESULT	ACTION TO TAKE
A11	CHECK CONTINUITY OF PIP CIRCUIT		
	<ul style="list-style-type: none"> • Key off. • Breakout box installed. • Disconnect processor. <p>For 3.0L SHO:</p> <ul style="list-style-type: none"> — Disconnect crankshaft sensor. — Disconnect DIS module (pins 1-6) connector. <p>For 2.3L Truck</p> <ul style="list-style-type: none"> — Disconnect DIS module (pins 1-6) connector. <p>For vehicles with "Integral" or "Pigtail" distributor hall:</p> <ul style="list-style-type: none"> — Disconnect distributor hall and TFI module. <p>For all others:</p> <ul style="list-style-type: none"> — Disconnect TFI module. <ul style="list-style-type: none"> • Measure resistance between Test Pin 56 at the breakout box and PIP circuit at the following connectors as appropriate: TFI, distributor hall, crankshaft sensor, DIS module or engine governor module. • Is resistance less than 5.0 ohms? 	<p>Yes</p> <p>No</p>	<p>REMOVE breakout box. RECONNECT all components. Go to IGNITION SYSTEM for TFI or DIS troubleshooting.</p> <p>SERVICE open circuit. REMOVE breakout box. RECONNECT all components. RERUN Quick Test.</p>
A12	SPOUT SIGNAL VERIFICATION		
	<ul style="list-style-type: none"> • Key off. • Disconnect processor 60 pin connector. Inspect for damaged or pushed out pins, corrosion, loose wires, etc. Service as necessary. • Install breakout box and connect processor to breakout box. • Ensure timing switch is in "Computed" position on breakout box. • Measure voltage between Test Pin 36 and Test Pins 40 and 60 at the breakout box during crank. • Is voltage between 3.0 and 6.0 volts? 	<p>Yes</p> <p>No</p>	<p>GO to A20 .</p> <p>GO to A8 .</p>
A13	ATTEMPT TO RESTART VEHICLE		
	<ul style="list-style-type: none"> • Key off. • Disconnect the engine governor module. • Attempt to start vehicle • Does the vehicle start? 	<p>Yes</p> <p>No</p>	<p>REPLACE engine governor module. RERUN Quick Test.</p> <p>GO to A14 .</p>

EEC-IV Pinpoint Test

TEST STEP		RESULT	ACTION TO TAKE
A14	CHECK CONTINUITY OF PIP CIRCUIT		
	<ul style="list-style-type: none"> • Key off. • Disconnect processor 60 pin connector. • Install breakout box, leave processor disconnected. • Engine governor module disconnected. • Measure resistance between pin 17 at the governor module and Test Pin 56 at the breakout box. • Is resistance less than 5 ohms? 	Yes  No 	GO to A15 . SERVICE open circuit. REMOVE breakout box. RECONNECT all components. RERUN Quick Test.
A15	CHECK CONTINUITY OF PIP CIRCUIT		
	<ul style="list-style-type: none"> • Key off. • Processor disconnected. • Disconnect distributor hall connector. • Measure resistance between PIP circuit at the distributor hall connector and Test Pin 56 at the breakout box. • Is resistance less than 5 ohms? 	Yes  No 	GO to A16 . SERVICE open circuit. REMOVE breakout box. RECONNECT all components. RERUN Quick Test.
A16	CHECK PIP CIRCUIT FOR SHORT TO POWER AND GROUND		
	<ul style="list-style-type: none"> • Key off. • Breakout box installed. • Processor disconnected. • Governor module disconnected. • Distributor hall disconnected. • Measure resistance between Test Pin 56 and Test Pins 16, 20, 40, 46, 60 (short to ground) and 26, 37, 57 (short to power). • Is each resistance greater than 10,000 ohms? 	Yes  No 	GO to A17 . SERVICE short circuit. REMOVE breakout box. RECONNECT all components. RERUN Quick Test.
A17	ISOLATE SHORTS IN PROCESSOR		
	<ul style="list-style-type: none"> • Key off. • Breakout box installed. • Reconnect processor to breakout box. • Measure resistance between Test Pin 56 and Test Pins 16, 20, 40, 46, 60 (short to ground) and 26, 37, 57 (short to power). • Is each resistance greater than 10,000 ohms? 	Yes  No 	GO to A18 . REPLACE processor. REMOVE breakout box. RECONNECT all components. RERUN Quick Test.

EEC-IV Pinpoint Test

TEST STEP		RESULT	ACTION TO TAKE
A18	CHECK PIP SIGNAL		
<ul style="list-style-type: none"> • Key off. • Breakout box installed, processor connected. • Reconnect distributor hall and engine governor module. • Measure voltage between Test Pin 56 and Test Pin 16 at the breakout box. • Is voltage between 3.0 and 7.0 volts? 		Yes	REPLACE processor. REMOVE breakout box. RECONNECT all components. RERUN Quick Test.
		No	GO to A5 .
A20	CHECK FUEL PRESSURE		
<div style="border: 1px solid black; padding: 2px; width: fit-content;">WARNING</div> <p>IF FUEL STARTS LEAKING, TURN KEY OFF IMMEDIATELY. NO SMOKING.</p> <ul style="list-style-type: none"> • Connect fuel pressure gauge. • Note initial pressure reading. • Observe pressure gauge as you pressurize fuel system. (Turn key to RUN for 1 second, then turn key to OFF. Wait 10 seconds. Repeat 5 times.) • Does fuel pressure increase? 		Yes	GO to Pinpoint Test S, Step S1 .
		No	TURN key OFF and GO to A21 .
A21	CHECK INERTIA SWITCH RESISTANCE		
<ul style="list-style-type: none"> • Key off. • Disconnect fuel pump inertia switch. Refer to Owner Guide for location. • Measure the resistance of the fuel pump inertia switch. • Is resistance less than 5.0 ohms? 		Yes	GO to Pinpoint Test J, Step J1 .
		No	VERIFY inertia switch is reset. If switch will not reset, REPLACE switch. REMOVE breakout box. RECONNECT all components. RERUN Quick Test.

EEC-IV Pinpoint Test

Pinpoint Test Schematic

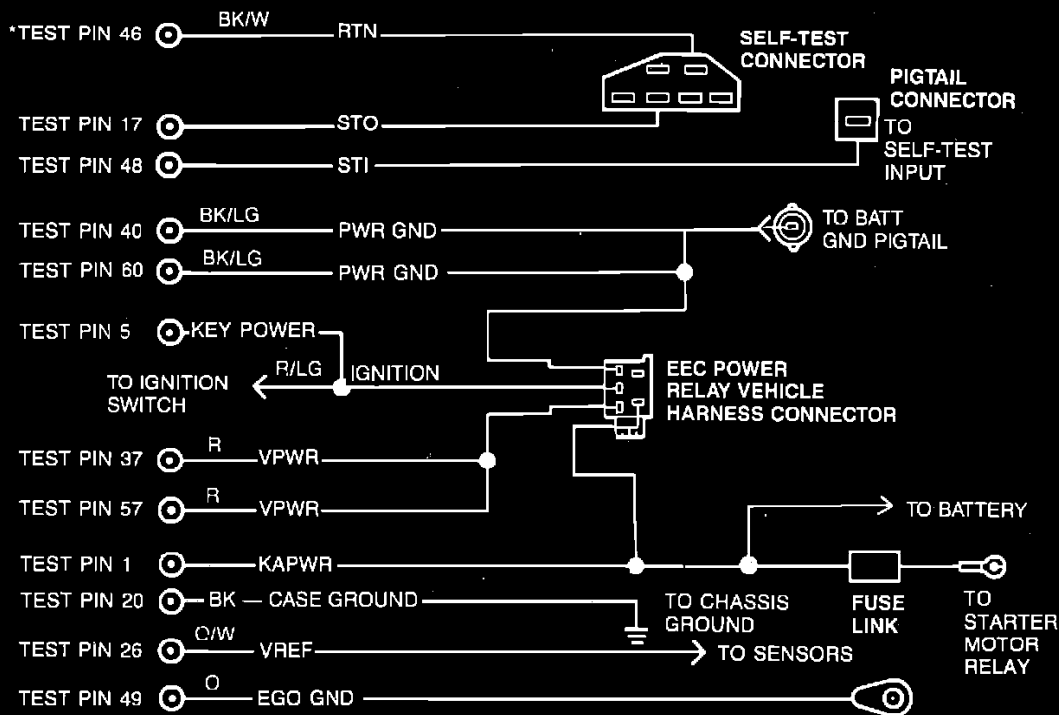

*TEST PINS LOCATED ON BREAKOUT BOX.
ALL HARNESS CONNECTORS VIEWED INTO MATING SURFACE.

EEC-IV Pinpoint Test

Test Pin 17		STO		Test Pin 1		KAPWR	
Application	Wire Color	Application	Wire Color	Application	Wire Color	Application	Wire Color
F-Series	PK/LG			E-Series	BK/0		
2.3L				All Others		Y	
3.0L MA							
4.0L Ranger/Explorer							
All Others	T/R						

Test Pin 48		STI	
Application	Wire Color	Application	Wire Color
2.3L	W/BK		
2.9L			
3.0L EFI/MA			
4.0L Ranger			
All Others	W/R		

EEC-IV Pinpoint Test

Note

You should enter this Pinpoint Test only when directed here from Pinpoint Tests C , J or P

Remember

To prevent the replacement of good components, be aware that the following non-EEC areas may be at fault:

- Ignition Switch
- Battery Cables
- Alternator
- Voltage Regulator
- Ground Straps

This Pinpoint Test is intended to diagnose only the following:

- Processor (-12A650-)
- Harness circuits: SIG RTN, STO, STI, PWR GND, GROUND, VPWR, KAPWR, VREF, IGNITION
- Battery Voltage
- Power Relay (-12A646-)

EEC-IV Pinpoint Test

TEST STEP		RESULT	ACTION TO TAKE
B1	CHECK BATTERY VOLTAGE		
	<ul style="list-style-type: none"> • Key on, engine off. • Measure voltage across battery terminals. • Is voltage greater than 10.5 volts? 	Yes No	GO to B2 . SERVICE discharged battery. Go to STARTING AND CHARGING SYSTEMS .
B2	CHECK PWR GND CIRCUIT CONTINUITY		
	<ul style="list-style-type: none"> • Key off. • Disconnect processor 60 pin connector. Inspect for damaged or pushed out pins, corrosion, loose wires, etc. Service as necessary. • Install breakout box and connect processor to breakout box. • Measure resistance between battery negative post and Test Pins 40 and 60 at the breakout box. • Is each resistance less than 5 ohms? 	Yes No	GO to B3 . SERVICE open in PWR GND circuit. REMOVE breakout box. RECONNECT processor. RERUN Quick Test.
B3	CHECK FOR OPEN BETWEEN SIG RTN AND PWR GND CIRCUITS AT PROCESSOR		
	<ul style="list-style-type: none"> • Key off. • Breakout box installed, processor connected. • Measure resistance between Test Pin 46 and Test Pins 40 and 60 at the breakout box. • Is each resistance less than 5 ohms? 	Yes No	GO to B4 . REPLACE processor. REMOVE breakout box. RERUN Quick Test.

EEC-IV Pinpoint Test

TEST STEP		RESULT	ACTION TO TAKE
B4	CHECK SIG RTN CIRCUIT CONTINUITY		
<ul style="list-style-type: none"> • Key off. • Breakout box installed, processor connected. • DVOM on 200 ohm scale. • Measure resistance between Test Pin 46 at the breakout box and SIG RTN circuit in the Self-Test connector. • Is resistance less than 5.0 ohms? 		Yes No	GO to B5 . SERVICE open in SIG RTN circuit. REMOVE breakout box. RECONNECT processor. RERUN Quick Test.
B5	CHECK KAPWR CIRCUIT VOLTAGE AT EEC POWER RELAY		
<ul style="list-style-type: none"> • Key on, engine off. • Measure voltage between KAPWR circuit at the EEC power relay vehicle harness connector and battery negative post. • Is voltage greater than 10.5 volts? 		Yes No	GO to B6 . SERVICE open in KAPWR circuit between EEC power relay and battery positive post. REMOVE breakout box. RECONNECT processor. RERUN Quick Test.
B6	CHECK IGNITION CIRCUIT VOLTAGE AT EEC POWER RELAY		
<ul style="list-style-type: none"> • Key on, engine off. • Measure voltage between the battery negative post and IGNITION circuit at the EEC power relay vehicle harness connector. • Is voltage greater than 10.5 volts? 		Yes No	GO to B7 SERVICE open in ignition switch circuits. REMOVE breakout box. RECONNECT processor. RERUN Quick Test.

EEC-IV Pinpoint Test

TEST STEP		RESULT	ACTION TO TAKE
B7	CHECK PWR GND CIRCUIT CONTINUITY		
	<ul style="list-style-type: none"> • Key off. • Measure resistance between PWR GND circuit at the EEC power relay vehicle harness connector and battery negative post. • Is the resistance less than 10 ohms? 	<p>Yes</p> <p>No</p>	<p>GO to B8.</p> <p>SERVICE open circuit. REMOVE breakout box. RECONNECT processor. RERUN Quick Test.</p>
B8	CHECK VPWR CIRCUIT VOLTAGE AT EEC POWER RELAY		
	<ul style="list-style-type: none"> • Key on, engine off. • Measure voltage between battery negative post and VPWR circuit at the EEC power relay vehicle harness connector. • Is the voltage greater than 10.5 volts? 	<p>Yes</p> <p>No</p>	<p>SERVICE open or short to ground in VPWR circuit between processor and EEC power relay. REMOVE breakout box. RECONNECT processor. RERUN Quick Test.</p> <p>REPLACE EEC power relay. REMOVE breakout box. RECONNECT processor. RERUN Quick Test.</p>

EEC-IV Pinpoint Test

Note

You should enter this Pinpoint Test only when a check for VREF has failed in the sensor Pinpoint Tests (D-Series) or Pinpoint Tests A or QA .

Remember

This Pinpoint Test is intended to diagnose only the following:

- Sensor harness circuits: SIG RTN, VREF
- 3-Wire Sensors: TP, EVP, PFE, DPFE, MAP, BP
- Processor assembly (-12A650-)

Pinpoint Test Schematic

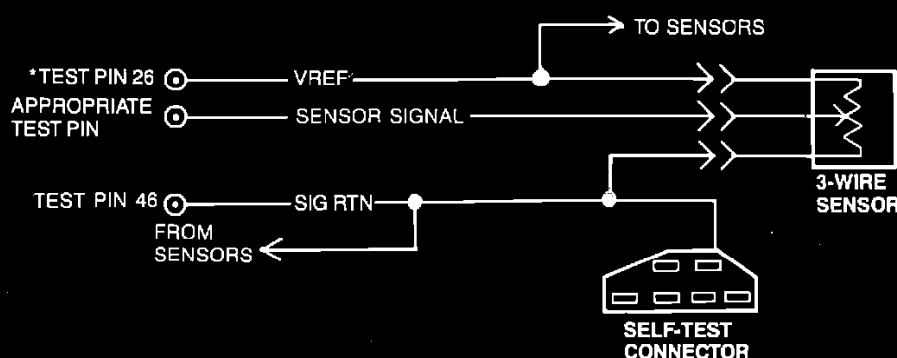

*TEST PINS LOCATED ON BREAKOUT BOX.
ALL HARNESS CONNECTORS VIEWED INTO MATING SURFACE.

Test Pin 26	VREF
Application	Wire Color
All	BR/W

Test Pin 46	SIG RTN
Application	Wire Color
All	GY/R

EEC-IV Pinpoint Test

TEST STEP		RESULT	ACTION TO TAKE
C1	CHECK VEHICLE BATTERY POWER CIRCUIT		
	<ul style="list-style-type: none"> • Key off. • Disconnect 60 pin connector. Inspect for damaged or pushed out pins, corrosion, loose wires, etc. Service as necessary. • Install breakout box and connect processor to breakout box. • Key on, engine off. • Measure voltage between Test Pin 37 at the breakout box and SIG RTN circuit in the Self-Test connector. Note voltage. • Measure voltage across battery terminals. Note voltage. • Are both voltages greater than 10.5 volts; and are both voltages within 1.0 volt of each other? 	<p>Yes ▶</p> <p>No ▶</p>	<p>GO to C2 .</p> <p>RECONNECT sensor (if applicable).</p> <p>GO to PINPOINT TEST B, STEP B1.</p>
C2	CHECK VREF VOLTAGE		
	<ul style="list-style-type: none"> • Key on, engine off. • Breakout box installed, processor connected. • Measure voltage between Test Pin 26 and Test Pin 46 at the breakout box. • What is the voltage? 	<p>Greater than 6.0 volts ▶</p> <p>Less than 4.0 volts ▶</p> <p>Between 4.0 volts and 6.0 volts ▶</p>	<p>GO to C4 .</p> <p>GO to C5 .</p> <p>GO to C3 .</p>
C3	CHECK VREF AND SIG RTN CIRCUITS FOR CONTINUITY		
	<ul style="list-style-type: none"> • Key off. • Sensor that sent you here disconnected. • Breakout box installed. • Disconnect processor. • Measure resistance between Test Pin 26 at breakout box and VREF circuit at vehicle harness connector of the sensor that sent you here. • Measure resistance between Test Pin 46 at breakout box and SIG RTN circuit at vehicle harness connector of the sensor that sent you here. • Is each resistance less than 5.0 ohms? 	<p>Yes ▶</p> <p>No ▶</p>	<p>Reference voltage OK. REMOVE breakout box. RECONNECT sensor. RERUN Quick Test.</p> <p>SERVICE open in VREF or SIG RTN circuits. REMOVE breakout box. RECONNECT all components. RERUN Quick Test.</p>

EEC-IV Pinpoint Test

TEST STEP		RESULT	ACTION TO TAKE
C4	CHECK FOR EXCESS VOLTAGE ON VREF CIRCUIT		
<ul style="list-style-type: none"> • Key off. • Breakout box installed. • Disconnect processor. • Disconnect Star Tester (if applicable). <p>NOTE: For proper results of this test, the STAR Tester must be disconnected. Due to the circuitry of the STAR Tester and the vehicle, KAPWR can be fed to the VREF circuit giving the false indication of a short to power.</p> <ul style="list-style-type: none"> • Key on, engine off. • Measure voltage between Test Pin 26 at the breakout box and battery ground. • Is voltage less than 0.5 volts? 		<p>Yes</p> <p>No</p>	<p>REPLACE processor. REMOVE breakout box. RECONNECT sensor. RERUN Quick Test.</p> <p>SERVICE short to battery power in vehicle harness. REMOVE breakout box. RECONNECT processor and sensor. RERUN Quick Test. If condition persists, REPLACE processor.</p>
C5	CHECK FOR SHORTED THROTTLE POSITION SENSOR		
<ul style="list-style-type: none"> • Key off. • Breakout box installed, processor connected. • Disconnect Throttle Position (TP) sensor from vehicle harness. • Key on, engine off. • Measure voltage between Test Pin 26 and Test Pin 46 at the breakout box. • Is voltage less than 4.0 volts? 		<p>Yes</p> <p>No</p>	<p>RECONNECT TP sensor: For vehicles equipped with EVP/PFE/DPFE sensor: GO to C6 .</p> <p>For all other vehicles: GO to C7 .</p> <p>REPLACE TP sensor. REMOVE breakout box. RECONNECT all components. RERUN Quick Test.</p>

EEC-IV Pinpoint Test

TEST STEP		RESULT	ACTION TO TAKE
C6	CHECK FOR SHORTED EVP/PFE/DPFE SENSOR		
<ul style="list-style-type: none"> • Key off. • Breakout box installed, processor connected. • Disconnect EVP/PFE/DPFE sensor. • Key on, engine off. • Measure voltage between Test Pin 26 and Test Pin 46 at the breakout box. • Is voltage less than 4.0 volts? 		Yes	RECONNECT EVP/PFE/DPFE sensor. GO to C7 .
		No	REPLACE EVP/PFE/DPFE sensor. REMOVE breakout box. RECONNECT all components. RERUN Quick Test.
C7	CHECK FOR SHORTED MAP/BP SENSOR		
<p>NOTE: For vehicle not equipped with a MAP/BP sensor, go to C9</p> <ul style="list-style-type: none"> • Key off. • Breakout box installed, processor connected. • Disconnect MAP/BP sensor. • Key on, engine off. • Measure voltage between Test Pin 26 and Test Pin 46 at the breakout box. • Is voltage less than 4.0 volts? 		Yes	RECONNECT MAP/BP sensor. GO to C9
		No	REPLACE MAP/BP sensor. REMOVE breakout box. RECONNECT processor and sensor(s). RERUN Quick Test.

EEC-IV Pinpoint Test

TEST STEP		RESULT	ACTION TO TAKE
C8	CHECK FOR SHORTED 4EAT MODULE		
<ul style="list-style-type: none"> • Key off. • Breakout box installed, processor connected. • Disconnect both 4EAT(A/T) module vehicle harness connectors. • Key on, engine off. • Measure voltage between Test Pin 26 and Test Pins 46 at the breakout box. • Is voltage less than 4.0 volts? 		<p>Yes</p> <p>No</p>	<p>RECONNECT both 4EAT (A/T) connectors. GO to C9 .</p> <p>REMOVE breakout box. RECONNECT all components except 4EAT module. GO to TRANSMISSION, CLUTCHES, DIFFERENTIALS, AXLES, AND DRIVE SHAFTS for 4EAT troubleshooting.</p>
C9	CHECK VREF CIRCUIT FOR SHORT TO GROUND		
<ul style="list-style-type: none"> • Key off. • Breakout box installed. • Disconnect processor. • Disconnect TP sensor. • Disconnect EVP/PFE/DPFE, MAP/BP, and 4EAT module, if so equipped. • Measure resistance between Test Pin 26 and Test Pins 20, 40, 46 and 60 at the breakout box. • Is any resistance less than 5 ohms? 		<p>Yes</p> <p>No</p>	<p>SERVICE short to ground. REMOVE breakout box. RECONNECT all components. CONNECT all sensors. RERUN Quick Test. If original condition still exists, REPLACE processor.</p> <p>REPLACE processor. REMOVE breakout box. RECONNECT all components. RERUN Quick Test.</p>

EEC-IV Pinpoint Test

Notes:

Engine coolant temperature must be greater than 50°F to pass the KOEO test and greater than 180°F to pass the KOER test. To accomplish this, the engine should be at normal operating temperature.

Ambient temperature should be above 50°F to receive acceptable input from the Air Charge Temperature sensor.

Voltage values were calculated for VREF=5.0 volts. These values may vary 15 percent due to sensor and VREF variations.

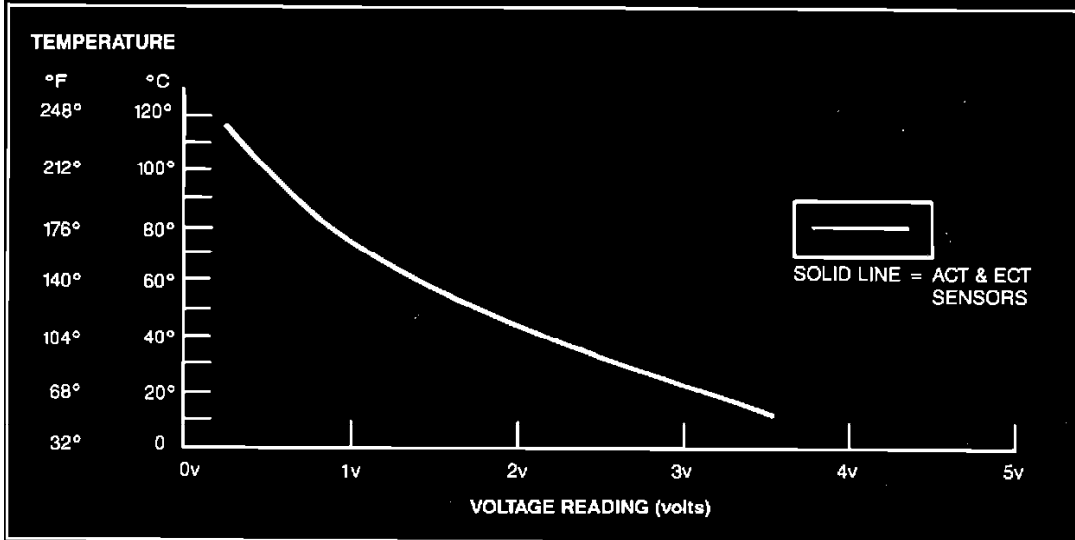

Temperature		Engine Coolant/Air Charge Temperature Sensor Values	
°F	°C	Voltage (volts)	Resistance (K ohms)
248	120	.27	1.18
230	110	.35	1.55
212	100	.46	2.07
194	90	.60	2.80
176	80	.78	3.84
158	70	1.02	5.37
140	60	1.33	7.70
122	50	1.70	10.97
104	40	2.13	16.15
86	30	2.60	24.27
68	20	3.07	37.30
50	10	3.51	58.75

EEC-IV Pinpoint Test

Note

You should enter this Pinpoint Test only when you have been directed here from Quick Test.

Remember

To prevent the replacement of good components, be aware that the following non-EEC areas may be at fault:

- Coolant level
- Cooling System
- Electro drive cooling fan
- Water pump drive belt
- Engine operating temperature
- Engine oil level
- Thermostat
- Air cleaner duct
- Ambient temperature

This Pinpoint Test is intended to diagnose the following:

- ACT sensor (-12A697-)
- ECT sensor (-12A648-)
- Harness circuits: ACT, ECT, and SIG RTN
- Processor assembly (-12A650-)

EEC-IV Pinpoint Test

Pinpoint Test Schematic

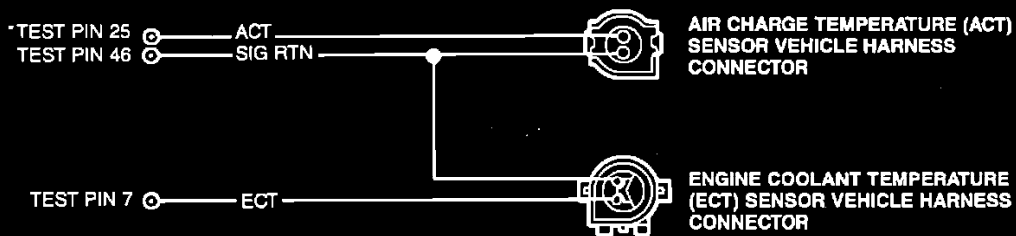

*TEST PINS LOCATED ON BREAKOUT BOX.
 ALL HARNESS CONNECTORS VIEWED INTO MATING SURFACE.

Test Pin 46	SIG RTN
Application	Wire Colors
All	GY/R

Test Pin 7	ECT
Application	Wire Colors
All	LG/R

Test Pin 25	ACT
Application	Wire Colors
2.3L EFI Ranger	GY
2.9L EFI	
2.9L MA EFI	
3.0L MA EFI	
4.0L MA EFI	
4.9L EFI F-Series, Bronco	R/BK
5.0L EFI F-Series, Bronco	
5.8L EFI F-Series, Bronco	
7.5L EFI F-Series	
4.9L EFI E-Series	R/BK
5.0L EFI E-Series	
5.8L EFI E-Series	
7.5L EFI E-Series	
All Others	LG/P

EEC-IV Pinpoint Test

TEST STEP		RESULT	ACTION TO TAKE
DA1	SERVICE CODE 21/116 OR 24/114: CHECK OPERATION, INSTALLATION OF TEMPERATURE SENSOR		
	<p>Service code 21/116 (ECT) or 24/114 (ACT) indicates that the corresponding sensor is out of Self-Test range. Correct range of measure is 0.3 to 3.7 volts.</p> <p>Possible causes:</p> <ul style="list-style-type: none"> — ACT sensor improperly mounted in air cleaner (2.5L only). — Low coolant level (ECT). — Ambient temperature below 50°F (ACT). — Faulty harness connector. — Faulty sensor. <ul style="list-style-type: none"> • Run engine for 2 minutes at 2000 rpm. <ul style="list-style-type: none"> — For NO STARTS: GO to DA3 . — For vehicle STALLS: GO to PINPOINT TEST S, STEP S1. 	<p>Yes</p> <p>No</p>	<p>GO to DA2 .</p> <p>SERVICE other codes as necessary.</p>
DA2	CHECK VREF CIRCUIT VOLTAGE AT THROTTLE POSITION SENSOR		
	<ul style="list-style-type: none"> • Refer to schematic below • Key off. • Disconnect TP sensor. • Key on, engine off. • Measure voltage between VREF circuit and SIG RTN circuit at the TP sensor vehicle harness connector. • Is voltage between 4.0 volts and 6.0 volts? 	<p>Yes</p> <p>No</p>	<p>RECONNECT TP sensor. GO to DA3 .</p> <p>GO to PINPOINT TEST C, STEP C1.</p>

EEC-IV Pinpoint Test

Pinpoint Test Schematic

- *TEST PIN 46 ○ — SIG RTN
- TEST PIN 47 ○ — TP
- *TEST PIN 26 ○ — VREF



THROTTLE POSITION (TP) SENSOR VEHICLE HARNESS CONNECTOR



THROTTLE POSITION (TP) SENSOR CONNECTOR



ALTERNATE THROTTLE POSITION (TP) SENSOR VEHICLE HARNESS CONNECTOR



ALTERNATE THROTTLE POSITION (TP) SENSOR CONNECTOR

*TEST PINS LOCATED ON BREAKOUT BOX.
ALL HARNESS CONNECTORS VIEWED INTO MATING SURFACE.

EEC-IV Pinpoint Test

TEST STEP		RESULT	ACTION TO TAKE
DA3	CHECK RESISTANCE OF TEMPERATURE SENSOR WITH ENGINE OFF		
<ul style="list-style-type: none"> • Key off. • Disconnect suspect temperature sensor. • Measure resistance between sensor signal circuit and SIG RTN circuit at the temperature sensor. Refer to the corresponding chart at the beginning of this Pinpoint Test for resistance specifications. • Is resistance within specifications? 		Yes	<p>▶ For ECT sensor with a NO START: Do not service code 21/116 at this time. GO to PINPOINT TEST A, STEP A1</p> <p>▶ For all others: GO to DA4 .</p>
		No	▶ REPLACE suspect sensor. RECONNECT vehicle harness. RERUN Quick Test.
DA4	CHECK RESISTANCE OF TEMPERATURE SENSOR WITH ENGINE RUNNING		
<p>NOTE: Engine may have cooled down. Always warm engine before taking ECT sensor resistance measurements. Check for open thermostat.</p> <ul style="list-style-type: none"> • Key off. • Suspect temperature sensor disconnected. • Run engine for 2 minutes at 2000 rpm. • Measure resistance between sensor signal circuit and SIG RTN circuit at the temperature sensor. Refer to the corresponding chart at the beginning of this Pinpoint Test for resistance specifications. • Is resistance within specification? 		Yes	▶ REPLACE processor. RECONNECT vehicle harness. RERUN Quick Test.
		No	▶ REPLACE suspect sensor. RECONNECT vehicle harness. RERUN Quick Test.

EEC-IV Pinpoint Test

TEST STEP	RESULT	ACTION TO TAKE
<p>DA10 SERVICE CODE 51/118 OR 54/113: INDUCE OPPOSITE CODE 61/117 OR 64/112</p> <p>Service codes 51/118 (ECT) or 54/113 (ACT) and 58 (VAT) indicate that the corresponding sensor signal is greater than the Self-Test maximum. The maximum for ECT and ACT sensors is 4.6 volts.</p> <p>Possible causes:</p> <ul style="list-style-type: none"> — Open in harness (ACT or ECT). — Faulty connection. — Faulty sensor. — Faulty processor. • Key off. • Disconnect suspect temperature sensor. • Connect a jumper wire between the sensor signal circuit and SIG RTN circuit at the temperature sensor vehicle harness connector. • Run Key On Engine Off Self-Test. • Is Code 61, 64, 112, or 117 present? 	<p>Yes</p> <p>No</p>	<p>REPLACE suspect sensor. REMOVE jumper wire. RECONNECT vehicle harness. RERUN Quick Test.</p> <p>REMOVE jumper wire. GO to DA11 .</p>
<p>DA11 CHECK CONTINUITY OF SENSOR SIGNAL AND SIG RTN CIRCUITS</p> <ul style="list-style-type: none"> • Key off. • Suspect temperature sensor disconnected. • Disconnect processor Pin 60 connector. Inspect for damaged or pushed out pins, corrosion, loose wires, etc. Service as necessary. • Install breakout box, leave processor disconnected. • Measure resistance between sensor signal circuit at the temperature sensor vehicle harness connector and Test Pin 7 (ECT) or 25 (ACT) at the breakout box. • Measure resistance between SIG RTN circuit at the temperature sensor vehicle harness connector and Test Pin 46 at the breakout box. • Is each resistance less than 5 ohms? 	<p>Yes</p> <p>No</p>	<p>REPLACE processor. REMOVE breakout box. RECONNECT all components. RERUN Quick Test.</p> <p>SERVICE open circuits. REMOVE breakout box. RECONNECT all components. RERUN Quick Test.</p>

EEC-IV Pinpoint Test

TEST STEP		RESULT	ACTION TO TAKE
DA20	SERVICE CODE 61/117 OR 64/112: INDUCE OPPOSITE CODE 51/118 OR 54/113		
	<p>Service codes 61/117(ECT) 64/112(ACT) indicate that the corresponding sensor's signal is less than the Self-Test minimum. The ACT and ECT sensor minimum is 0.2 volts.</p> <p>Possible causes:</p> <ul style="list-style-type: none"> — Grounded circuit in harness. — Faulty sensor. — Faulty processor. — Faulty connection. • Key off. • Disconnect vehicle harness from suspect sensor. Inspect for damaged, corroded, pushed out pins or loose wires, etc. Service as necessary. • Run Key On Engine Off Self-Test. • Is code 51, 54, 113 or 118 present? 	<p>Yes</p> <p>No</p>	<p>REPLACE sensor. RECONNECT harness. RERUN Quick Test.</p> <p>GO to DA21 .</p>
DA21	CHECK VREF CIRCUIT VOLTAGE AT THROTTLE POSITION SENSOR		
	<ul style="list-style-type: none"> • Refer to schematic following step DA2. • Key off. • Suspect temperature sensor disconnected. • Disconnect TP sensor. • Key on, engine off. • Measure voltage between VREF circuit and SIG RTN circuit at the TP sensor vehicle sensor connector. • Is voltage between 4.0 volts and 6.0 volts? 	<p>Yes</p> <p>No</p>	<p>RECONNECT TP sensor, GO to DA22 .</p> <p>GO to Pinpoint Test Step C1 .</p>
DA22	CHECK TEMPERATURE SENSOR SIGNAL CIRCUIT FOR SHORT TO GROUND		
	<ul style="list-style-type: none"> • Key off. • Suspect temperature sensor disconnected. • Disconnect processor Pin 60 connector. Inspect for damaged or pushed out pins, corrosion, loose wires, etc. Service as necessary. • Install breakout box, leave processor disconnected. • Measure resistance between Test Pin 7 (ECT) or 25 (ACT) and Test Pins 40, 46 and 60 at the breakout box. • Is each resistance greater than 10,000 ohms? 	<p>Yes</p> <p>No</p>	<p>REPLACE processor. REMOVE breakout box. RECONNECT all components. RERUN Quick Test.</p> <p>SERVICE short circuit. REMOVE breakout box. RECONNECT all components. RERUN Quick Test.</p>

EEC-IV Pinpoint Test

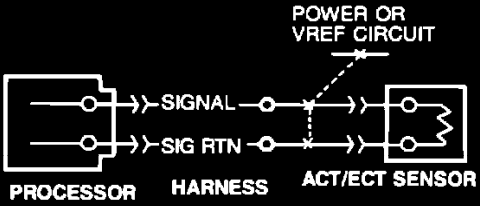
TEST STEP		RESULT	ACTION TO TAKE					
DA90	CONTINUOUS MEMORY CODE 51/118, 54/113, 61/117, OR 68/112: CHECK SENSOR							
<p>Continuous Memory codes 51/118 and 54/113, indicate that the sensor signal was greater than the Self-Test maximum of 4.6 volts. The code was generated under normal driving conditions.</p> <p>Continuous Memory codes 61/117 and 64/112, indicate that the sensor signal was less than the Self-Test minimum of 0.2 volts. The code was generated under normal driving conditions.</p> <table border="1"> <thead> <tr> <th>Sensors</th> <th>Continuous Memory Codes</th> </tr> </thead> <tbody> <tr> <td>ACT</td> <td>54/113 and 64/112</td> </tr> <tr> <td>ECT</td> <td>51/118 and 61/117</td> </tr> </tbody> </table> <p>Possible causes:</p> <ul style="list-style-type: none"> — Faulty sensor. — Open circuit in harness. — Grounded circuit in harness. — Faulty processor. • Enter Key On Engine Off continuous monitor mode. Refer to Quick Test Appendix. • Observe VOM or STAR LED for indication of a fault while performing the following: <ul style="list-style-type: none"> — Tap on the sensor to simulate road shock. — Wiggle the sensor connector. • Is a fault indicated? 		Sensors	Continuous Memory Codes	ACT	54/113 and 64/112	ECT	51/118 and 61/117	<p>Yes</p> <p>▶ DISCONNECT and inspect connectors. If OK, REPLACE the sensor. CLEAR Continuous Memory (Refer to TESTING PROCEDURES/QUICK TEST AND DIAGNOSTIC AIDS/DETAILED QUICK TEST PROCEDURES/CONTINUOUS MEMORY CODES) RERUN Quick Test.</p>
Sensors	Continuous Memory Codes							
ACT	54/113 and 64/112							
ECT	51/118 and 61/117							
		<p>No</p> <p>▶ GO to DA91 .</p>						

EEC-IV Pinpoint Test

TEST STEP		RESULT	ACTION TO TAKE
DA91	CHECK EEC-IV VEHICLE HARNESS		
<ul style="list-style-type: none"> • Still in Key On Engine Off continuous monitor mode. • Observe VOM or STAR LED for fault indication while performing the following: <ul style="list-style-type: none"> — Refer to the illustration in Step DA90 . Grasp the vehicle harness close to the sensor connector. Wiggle, shake, or bend a small section of the EEC-IV system vehicle harness while working your way to the dash panel. Also wiggle, shake, or bend the EEC-IV system vehicle harness from the dash panel to the processor. • Is a fault indicated? 		Yes	ISOLATE fault and SERVICE as necessary. CLEAR Continuous Memory. RERUN Quick Test. Refer to TESTING PROCEDURES/QUICK TEST AND DIAGNOSTIC AIDS/DETAILED QUICK TEST PROCEDURES/CONTINUOUS MEMORY CODES.
		No	GO to DA92 .
DA92	CHECK PROCESSOR AND VEHICLE HARNESS CONNECTORS		
<ul style="list-style-type: none"> • Key off, wait 10 seconds. • Disconnect processor Pin 60 connector. Disconnect sensor connector. Inspect for damage, loose or pushed out pins, loose or poorly crimped wires. • Are connectors and terminals OK? 		Yes	Unable to duplicate and/or identify fault at this time. For further diagnosis using the EEC-IV Monitor box, Go to TESTING PROCEDURES/INTERMITTENT FAULT DIAGNOSIS. All others, CLEAR Continuous Memory. RERUN Quick Test. Refer to TESTING PROCEDURES/QUICK TEST AND DIAGNOSTIC AIDS/DETAILED QUICK TEST PROCEDURES/CONTINUOUS MEMORY CODES.
		No	SERVICE as necessary. CLEAR Continuous Memory. RERUN Quick Test. Refer to TESTING PROCEDURES/QUICK TEST AND DIAGNOSTIC AIDS/DETAILED QUICK TEST PROCEDURES/CONTINUOUS MEMORY CODES.

EEC-IV Pinpoint Test

MAP Sensor Graph

NOTE: MAP sensor output frequency versus manifold vacuum data is based on 30.0 in-Hg barometric pressure.

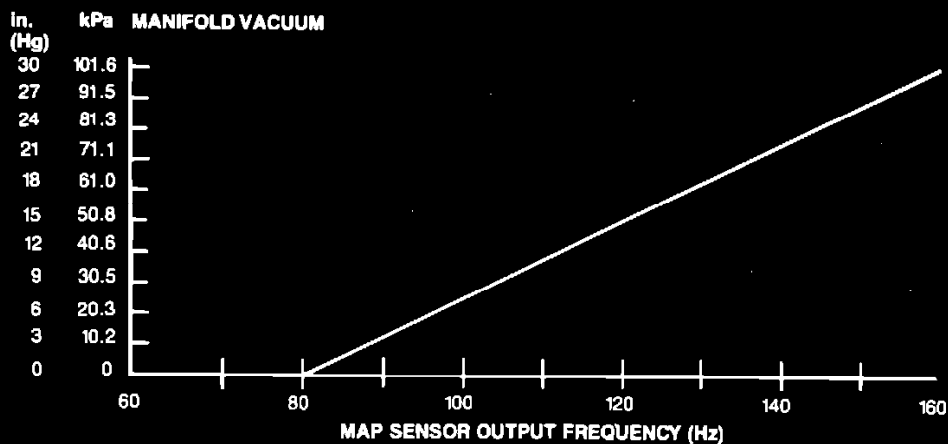

MAP Sensor Data

Manifold Vacuum		Frequency
in-Hg	kPa	Hz
0	0	159
3	10.2	150
6	20.3	141
9	30.5	133
12	40.6	125
15	50.8	117
18	61.0	109
21	71.1	102
24	81.3	95
27	91.5	88
30	101.6	80

EEC-IV Pinpoint Test

MAP/BP Sensor Graph (KOEO)

NOTE: Frequency may vary plus or minus 3 Hz from the values given due to sensor variations.

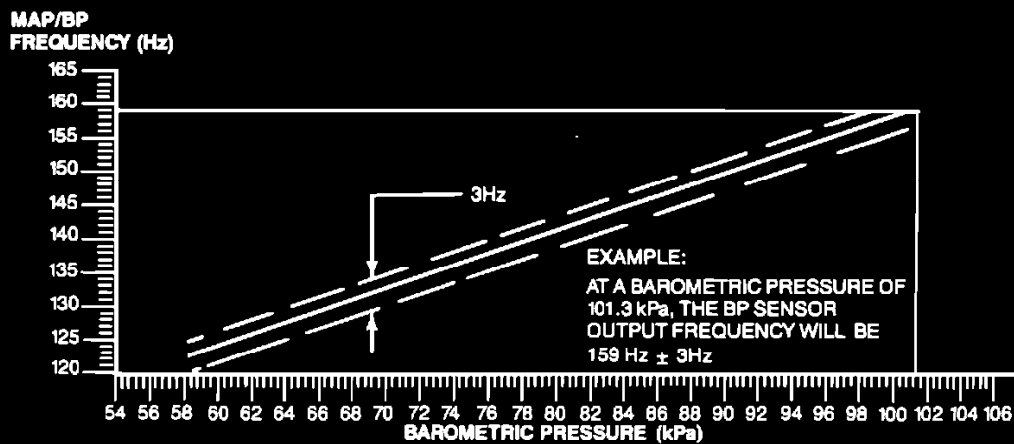

MAP/BP Sensor Data

Barometric Pressure in-Hg	Barometric Pressure kPa	Frequency Hz
17.1	58	122.4
18.3	62	125.5
19.5	66	128.7
20.7	70	131.9
21.8	74	135.1
23.0	78	138.3
24.2	82	141.8
25.4	86	145.4
26.6	90	148.9
27.7	94	152.5
28.9	98	156.1
30.1	102	159.6
31.0	105	162.4

EEC-IV Pinpoint Test

Pinpoint Test Schematic

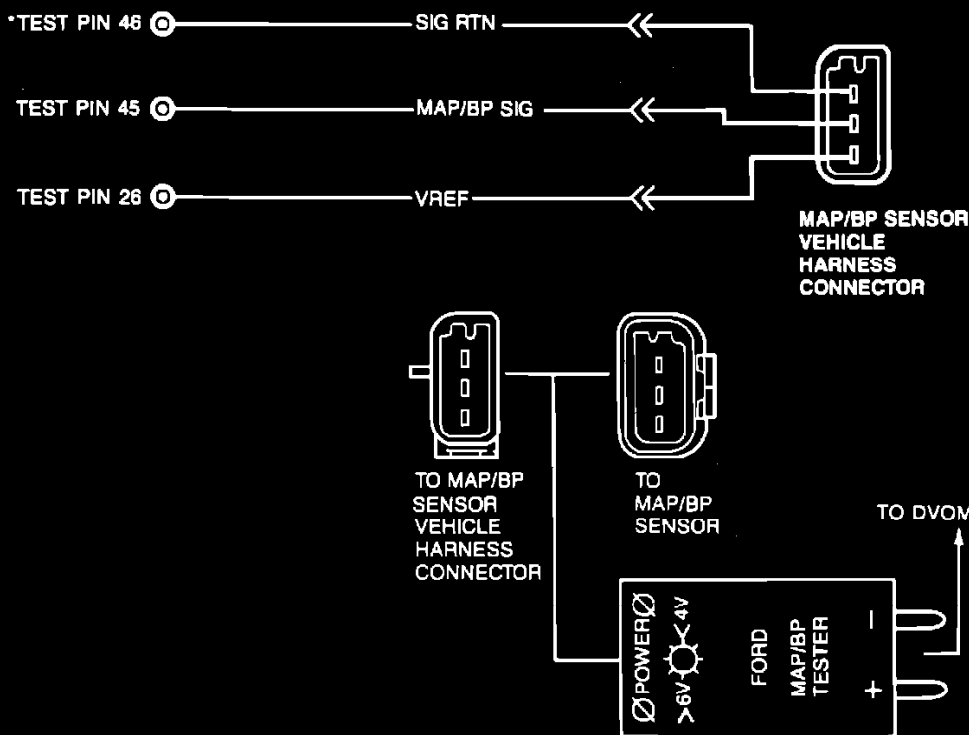

*TEST PINS LOCATED ON BREAKOUT BOX.
 ALL HARNESS CONNECTORS VIEWED INTO MATING SURFACE.

EEC-IV Pinpoint Test

Test Pin 45		MAP/BP SIG
Application	Wire Color	
3.0L Aerostar	DB/LG	
4.0L Aerostar		
4.9L E-Series		
5.0L E-Series		
5.8L E-Series		
7.3L E-Series Diesel		
7.5L E-Series		
All Others	LG/BK	
Test Pin 46		SIG RTN
Application	Wire Color	
All	GY/R	
Test Pin 26		VREF
Application	Wire Color	
All	BR/W	

EEC-IV Pinpoint Test

Note

You should enter this Pinpoint Test only when you have been directed here from Quick Test or Pinpoint Test **S**.

Remember

To prevent the replacement of good components, be aware that the following non-EEC areas may be at fault:

- Unusually high/low barometric pressure.
- Kinked or obstructed vacuum lines (MAP).
- Basic engine (valves, vacuum leaks, timing, EGR valve, etc.).

This Pinpoint Test is intended to diagnose only the following:

- MAP/BP sensor (9F479)
- Harness circuits: VREF, MAP/BP SIG, and SIG RTN
- Processor assembly (12A650)
- MAP vacuum line

EEC-IV Pinpoint Test

TEST STEP		RESULT	ACTION TO TAKE
DF1	SERVICE CODE 22/126: CHECK FOR POWER TO MAP/BP SENSOR		
	<p>Service Code 22/126 indicates that the Manifold Absolute Pressure (MAP)/Barometric Pressure (BP) sensor is out of Self-Test range. Correct MAP/BP tester range of measurement is typically from 1.4 to 1.6 volts.</p> <p>Possible causes:</p> <ul style="list-style-type: none"> — MAP/BP SIG circuit open between sensor vehicle harness connector and processor. — MAP/BP SIG circuit shorted to VREF, SIG RTN, or GND. — Faulty MAP/BP sensor. — Vacuum trapped at MAP/BP sensor. — High atmospheric pressure. — Faulty processor. — VREF circuit open at MAP/BP sensor. — SIG RTN circuit open at MAP/BP sensor. <ul style="list-style-type: none"> • Key off. • Disconnect the MAP/BP sensor from the vehicle harness. • Connect the MAP/BP tester between the vehicle harness connector and the MAP/BP sensor. • Insert MAP/BP tester banana plugs into DVOM. <p>NOTE: Green light on tester indicates VREF is OK (4-6v). Red light (or no light) indicates VREF is either too low or too high.</p> <ul style="list-style-type: none"> • Key on. • Is green light on? 	<p>Yes</p> <p>No</p>	<p>GO to DF3 .</p> <p>GO to DF2 .</p>
DF2	CHECK FOR POWER AT SENSOR VEHICLE HARNESS CONNECTOR		
	<p>NOTE: Green light reaffirms that VREF is OK (4-6v). Red light (or no light) indicates VREF is either too low or too high.</p> <ul style="list-style-type: none"> • Key on. • MAP/BP tester connected. • DVOM connected to MAP/BP tester. • Disconnect MAP/BP sensor. • Is green light on? 	<p>Yes</p> <p>No</p>	<p>REPLACE MAP/BP sensor. RERUN Quick Test.</p> <p>REMOVE MAP/BP tester. RECONNECT MAP/BP sensor. GO to Pinpoint Test C, STEP C1.</p>

EEC-IV Pinpoint Test

TEST STEP		RESULT	ACTION TO TAKE																		
DF3	CHECK MAP/BP SENSOR OUTPUT																				
<p>NOTE: Measure several known good MAP/BP sensors on available vehicles. The measured voltage will be typical for your location on the day of testing.</p> <ul style="list-style-type: none"> • Key on. • MAP/BP tester connected. • DVOM connected to MAP/BP tester. • Measure MAP/BP sensor voltage on customer vehicle. • Is DVOM voltage in range for your altitude? <table border="1"> <thead> <tr> <th><u>Approximate Altitude (Ft.)</u></th> <th><u>Voltage Output (+/- .04 Volts)</u></th> </tr> </thead> <tbody> <tr><td>0</td><td>1.59</td></tr> <tr><td>1000</td><td>1.56</td></tr> <tr><td>2000</td><td>1.53</td></tr> <tr><td>3000</td><td>1.50</td></tr> <tr><td>4000</td><td>1.47</td></tr> <tr><td>5000</td><td>1.44</td></tr> <tr><td>6000</td><td>1.41</td></tr> <tr><td>7000</td><td>1.39</td></tr> </tbody> </table>		<u>Approximate Altitude (Ft.)</u>	<u>Voltage Output (+/- .04 Volts)</u>	0	1.59	1000	1.56	2000	1.53	3000	1.50	4000	1.47	5000	1.44	6000	1.41	7000	1.39	<p>Yes</p> <p>No</p>	<p>REMOVE MAP/BP tester. GO to DF4 .</p> <p>REMOVE MAP/BP tester. GO to DF5 .</p>
<u>Approximate Altitude (Ft.)</u>	<u>Voltage Output (+/- .04 Volts)</u>																				
0	1.59																				
1000	1.56																				
2000	1.53																				
3000	1.50																				
4000	1.47																				
5000	1.44																				
6000	1.41																				
7000	1.39																				
DF4	CHECK MAP/BP SIG CIRCUIT CONTINUITY																				
<ul style="list-style-type: none"> • Key off. • MAP/BP sensor disconnected. • Disconnect processor 60 pin connector. Inspect for damaged or pushed out pins, corrosion, loose wires, etc. Service as necessary. • Install breakout box, leave processor disconnected. • Measure resistance between MAP/BP SIG circuit at the MAP/BP sensor vehicle harness connector and Test Pin 45 at the breakout box. • Is resistance less than 5.0 ohms? 		<p>Yes</p> <p>No</p>	<p>REPLACE processor. REMOVE breakout box. RECONNECT MAP/BP sensor. RERUN Quick Test.</p> <p>SERVICE open circuit. REMOVE breakout box. RECONNECT all components. RERUN Quick Test.</p>																		

EEC-IV Pinpoint Test

TEST STEP		RESULT	ACTION TO TAKE
DF5	CHECK MAP/BP SIG CIRCUIT FOR SHORTS TO VREF, SIG RTN AND GROUND		
	<ul style="list-style-type: none"> • Key off. • MAP/BP sensor disconnected. • Disconnect processor 60 pin connector. Inspect for damaged or pushed out pins, corrosion, loose wires, etc. Service as necessary. • Install breakout box, leave processor disconnected. • Measure resistance between Test Pin 45 and Test Pins 26, 46, 40 and 60 at the breakout box. • Is each resistance greater than 10,000 ohms? 	<p>Yes</p> <p>No</p>	<p>REPLACE MAP/BP sensor. REMOVE breakout box. RECONNECT processor. RERUN Quick Test.</p> <p>SERVICE short circuit. REMOVE breakout box. RECONNECT all components. RERUN Quick Test.</p>
DF7	ENGINE RUNNING SERVICE CODE 22/126: CHECK FOR EGR SERVICE CODES		
	<p>Service Code 22/126 (KOER) indicates the MAP/BP signal is out of range for Engine Running Self-Test.</p> <p>Possible causes:</p> <ul style="list-style-type: none"> — Faulty MAP/BP sensor. — Faulty vacuum hoses. — Excess EGR. <p>• Are Engine Running Service Codes 31, 32, 33, 34, 35, 327, 326, 328, 332, 334, 336 or 337 present?</p>	<p>Yes</p> <p>No</p>	<p>Refer to TESTING PROCEDURES/QUICK TEST AND DIAGNOSTIC AIDS/QUICK TEST CODES AND DEFINITIONS for appropriate Pinpoint Test.</p> <p>GO to DF8</p>
DF8	CHECK MAP SENSOR OPERATION		
	<ul style="list-style-type: none"> • Key off. • Disconnect vacuum supply hose from MAP sensor. • Install vacuum pump to MAP sensor. • Apply 18 in-Hg vacuum to MAP sensor. • Does MAP sensor hold vacuum? 	<p>Yes</p> <p>No</p>	<p>RELEASE vacuum. GO to DF9</p> <p>REPLACE MAP sensor. CONNECT vacuum supply hose to MAP sensor. RERUN Quick Test.</p>

EEC-IV Pinpoint Test

TEST STEP		RESULT	ACTION TO TAKE
DF9	ATTEMPT TO ELIMINATE ENGINE RUNNING SERVICE CODE 22 or 126		
<ul style="list-style-type: none"> • Key off. • Plug MAP sensor vacuum supply hose. • Start engine and maintain 1500 ± 100 engine rpm. • Slowly apply 15 in-Hg vacuum to MAP sensor. • While maintaining rpm, perform Engine Running Self-Test. • Is Engine Running Service Code 22 or 126 still present? <p>NOTE: Disregard any other Service Codes at this time.</p>		<p>Yes</p> <p>No</p>	<p>REPLACE MAP sensor. CONNECT vacuum supply hose to MAP sensor. RERUN Quick Test.</p> <p>INSPECT vacuum supply hose to MAP sensor. SERVICE as necessary. If OK, SERVICE other Engine Running Service Codes. If none, GO to Diagnostic Routines, for a low vacuum problem.</p>
DF10	SERVICE CODE 72/129: RERUN DYNAMIC RESPONSE TEST		
<p>Service Code 72/129 indicates that the MAP sensor output did not change enough during the Dynamic Response Test.</p> <p>Possible causes:</p> <ul style="list-style-type: none"> — System failed to detect partial WOT. — MAP sensor vacuum supply hose improper routing, blockage and/or linkage. — Faulty MAP sensor. <ul style="list-style-type: none"> • Rerun Engine Running Self-Test. Be sure a complete WOT is performed during the Dynamic Response portion of the test. • Is Engine Running Service Code 72 or 129 still present? 		<p>Yes</p> <p>No</p>	<p>GO to DF11</p> <p>SERVICE other Service Codes as necessary. If none, testing complete.</p>

EEC-IV Pinpoint Test

TEST STEP		RESULT	ACTION TO TAKE
DF11	SERVICE CODE 81/128: CHECK VACUUM HOSES		
	<p>Continuous Service Code 78/128 indicates the MAP sensor vacuum has not changed greater than 2 in-Hg during normal vehicle operation.</p> <p>Possible causes:</p> <ul style="list-style-type: none"> — MAP sensor vacuum supply hose improper routing, blockage and/or linkage. — MAP sensor leak. <ul style="list-style-type: none"> • Key off. • Check vacuum hoses for proper routing. Refer to VECI decal. Check MAP sensor vacuum supply hoses for disconnections, kinks or blockage. • Are vacuum hoses OK? 	<p>Yes</p> <p>No</p>	<p>GO to DF12 .</p> <p>SERVICE vacuum hoses as necessary. RERUN Quick Test.</p>
DF12	CHECK MAP SENSOR OPERATION		
	<ul style="list-style-type: none"> • Key off. • Disconnect vacuum supply hose from MAP sensor. • Install vacuum pump to MAP sensor. • Apply 18 in-Hg vacuum to MAP sensor. • Does MAP sensor hold vacuum? 	<p>Yes</p> <p>No</p>	<p>RELEASE vacuum. REMOVE vacuum pump. RECONNECT vacuum supply hose to MAP sensor. GO to DF13</p> <p>REPLACE MAP sensor. RECONNECT vacuum supply hose to MAP sensor. RERUN Quick Test.</p>
DF13	CHECK THAT VACUUM TO MAP SENSOR DECREASES DURING DYNAMIC RESPONSE		
	<ul style="list-style-type: none"> • Key off. • Tee a vacuum gauge in the intake manifold vacuum supply hose at the MAP sensor. • Perform Engine Running Self-Test while observing vacuum. • Did vacuum decrease by more than 10 in-Hg vacuum during Dynamic Response test? 	<p>Yes</p> <p>No</p>	<p>REPLACE MAP sensor. REMOVE vacuum gauge. RERUN Quick Test.</p> <p>EEC-IV system OK. GO to ENGINE MECHANICAL for probable causes affecting engine vacuum.</p>

EEC-IV Pinpoint Test

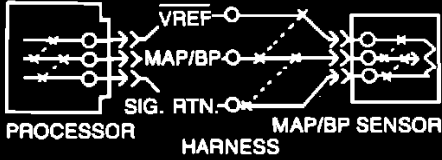
	TEST STEP	RESULT	ACTION TO TAKE
DF90	CONTINUOUS MEMORY CODE 22/126: EXERCISE MAP/BP SENSOR		
	<p>Continuous Memory Service Code 22/126 indicates the Manifold Absolute Pressure (MAP)/Barometric Pressure (BP) sensor was out of self-test range. The code was set during normal driving conditions. Correct range of measurement is typically from 1.4 to 1.6 volts.</p> <p>Possible causes:</p> <ul style="list-style-type: none"> — Faulty MAP/BP sensor. — Faulty EEC-IV vehicle harness. — Faulty MAP/BP sensor vehicle harness connectors and/or terminals. — Unusually high/low barometric pressure. <p>• Using Key On, Engine Off Continuous Monitor Mode, observe VOM or STAR LED for indication of a fault while performing the following:</p> <ul style="list-style-type: none"> — Connect a vacuum pump to the MAP/BP sensor. — Slowly apply 84 kPa (25 in-Hg) vacuum to the MAP/BP sensor. — Slowly bleed vacuum off the MAP/BP sensor. — Lightly tap on MAP/BP sensor (simulate road shock). — Wiggle MAP/BP connector. <p>• Is fault indicated?</p> 	<p>Yes</p> <p>No</p>	<p>DISCONNECT and INSPECT connectors. If connector and terminals are good, REPLACE MAP/BP sensor. RERUN Quick Test.</p> <p>GO to DF91 .</p>

EEC-IV Pinpoint Test

TEST STEP		RESULT	ACTION TO TAKE
DF91	CHECK EEC-IV VEHICLE HARNESS		
<ul style="list-style-type: none"> • Remain in Key On, Engine Off Continuous Monitor Mode. • Observe VOM or STAR LED for a fault indication while performing the following: <ul style="list-style-type: none"> — Referring to the illustration in Step DF90 , grasp the vehicle harness closest to the sensor connector. Wiggle, shake or bend a small section of the EEC-IV system vehicle harness while working your way to the dash panel. Also wiggle, shake or bend the EEC-IV vehicle harness from the dash panel to the processor. • Is a fault indicated? 		Yes	ISOLATE fault and SERVICE as necessary. CLEAR Continuous Memory Code Refer to TESTING PROCEDURES/QUICK TEST AND DIAGNOSTIC AIDS/ DETAILED QUICK TEST PROCEDURES/CONTINUOUS MEMORY CODES. RERUN Quick Test.
		No	GO to DF92 .
DF92	CHECK PROCESSOR AND VEHICLE HARNESS CONNECTORS		
<ul style="list-style-type: none"> • Key off. • Disconnect processor 60 pin connector. • Inspect connectors and connector terminals for obvious damage or faults. • Are connectors and terminals OK? 		No	SERVICE as necessary. RERUN Quick Test.
		Yes	Unable to duplicate and/or identify fault at this time. For further diagnosis using the EEC-IV monitor box. (Refer to TESTING PROCEDURES/QUICK TEST AND DIAGNOSTIC AIDS/ DETAILED QUICK TEST PROCEDURES/KEY ON ENGINE OFF SELF TEST for quick test procedures). All others, CLEAR Continuous Memory RERUN Quick Test

EEC-IV Pinpoint Test

Table #1

Throttle Position Sensor Specifications

Throttle Position Sensor Setting (K.O.E.O. and K.O.E.R.)			TP Circuit (Signal) Operating Voltage Range (K.O.E.O.)	
Engine Application	Rotational Degree Range	Voltage Range	Minimum	Maximum
2.3L DIS-EFI	1° - 13°	0.59 - 1.22	0.20	4.84
2.9L EFI	0° - 13°	0.49 - 1.22	0.34 0.20 (MA)	4.84
3.0L EFI	0° - 13°	0.59 - 1.22	0.20	4.84
4.0L EFI	0° - 13°	0.59 - 1.22	0.20	4.84
4.9L EFI	1° - 13°	0.66 - 1.22	0.34	4.84
5.0L EFI	1° - 13°	0.66 - 1.22	0.34	4.84
5.8L EFI	1° - 13°	0.66 - 1.22	0.34	4.84
7.0L EFI	1° - 13°	0.66 - 1.22	0.34	4.84
7.5L EFI	1° - 13°	0.66 - 1.22	0.34	4.84
4.9L/5.0L/5.8L/7.5L EFI E4OD	1° - 13°	0.66 - 1.22	0.34	4.84

EEC-IV Pinpoint Test

Pinpoint Test Schematic

*TEST PIN 46 ○ — SIG RTN

TEST PIN 47 ○ — TP

*TEST PIN 26 ○ — VREF

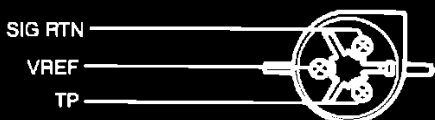
THROTTLE
POSITION (TP)
SENSOR
VEHICLE
HARNESS
CONNECTORTHROTTLE
POSITION (TP)
SENSOR
CONNECTORALTERNATE THROTTLE
POSITION (TP) SENSOR
VEHICLE HARNESS
CONNECTORALTERNATE THROTTLE
POSITION (TP)
SENSOR
CONNECTOR

*TEST PINS LOCATED ON BREAKOUT BOX.
ALL HARNESS CONNECTORS VIEWED INTO MATING SURFACE.

EEC-IV Pinpoint Test

Test Pin 46		SIG RTN	
Application		Wire Color	
All		GY/R	

Test Pin 26		VREF	
Application		Wire Color	
All		BR/W	

Test Pin 47		TP	
Application		Wire Color	
All		GY/W	

EEC-IV Pinpoint Test

Note

You should enter this Pinpoint Test only when you have been directed here from Quick Test.

Remember

To prevent the replacement of good components, be aware that the following non-EEC areas may be at fault:

- Idle speeds/throttle stop adjustment
- Binding throttle shaft/linkage or speed control linkage
- Choke/high cam system, if equipped
- TP sensor may not be seated properly (tightened down)

This Pinpoint Test is intended to diagnose only the following:

- Throttle Position (TP) sensor (9B989)
- Sensor harness circuits: VREF, TP, and SIG RTN
- Processor assembly (12A650)

EEC-IV Pinpoint Test

NOTE: The normal range of the throttle angle measurement for the Throttle Position (TP) sensor is from 0 to 85 degrees. To pass Quick Test, the throttle rotational setting on the TP sensor (Key On Engine Off and Key On Engine Running), and the maximum/minimum TP circuit operating voltage ranges are listed in Table # 1 by engine application.

TP Sensor Graph

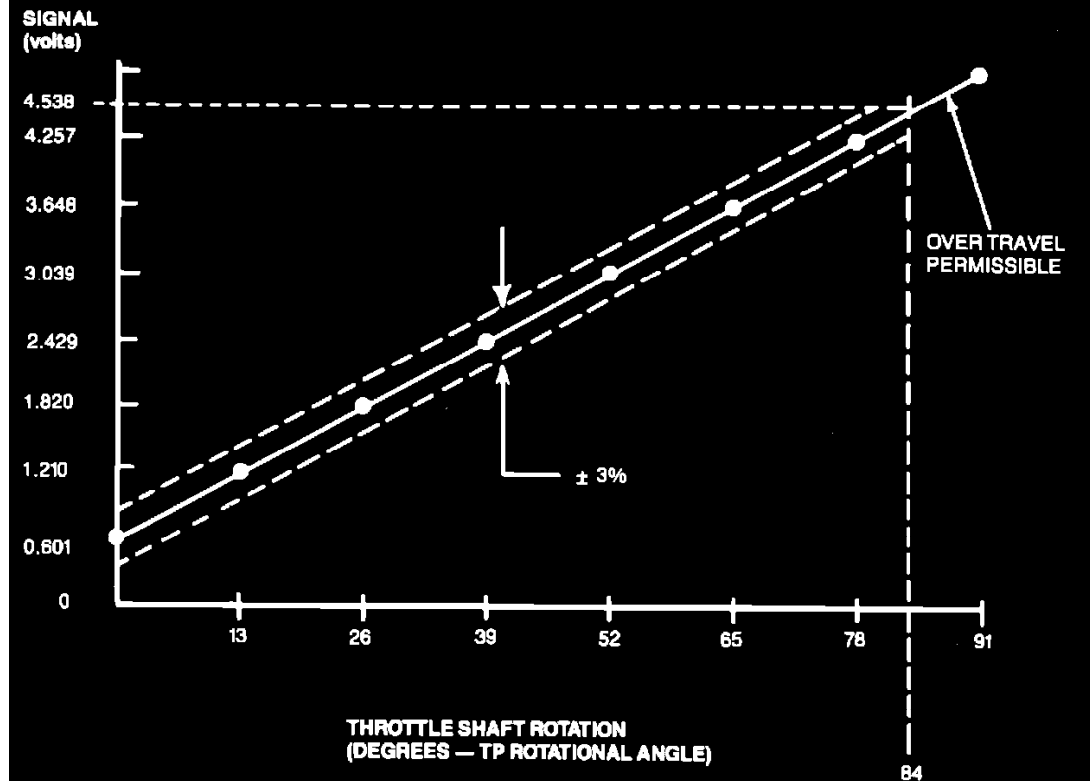

EEC-IV Pinpoint Test

TEST STEP		RESULT	ACTION TO TAKE
DH1	ENGINE RUNNING SERVICE CODE 23/121; CHECK FOR OTHER SERVICE CODES		
<p>Service Code 23/121 indicates that the Throttle Position (TP) sensor's rotational setting may be out of Self-Test range (refer to Table #1).</p> <p>Possible causes are:</p> <ul style="list-style-type: none"> — Binding throttle linkage. — TP sensor may not be seated properly (tightened down). — Faulty TP sensor. — Faulty processor. <ul style="list-style-type: none"> • Check for Codes 31/327 in Key On Engine Running Self-Test. • Are either of the above codes present with Code 23 or 121? 		<p>Yes</p> <p>No</p>	<p>RETURN to the Key On Engine Running Service Code chart and PROCEED as directed with Code 31/327.</p> <p>GO to DH2 .</p>
DH2	SERVICE CODE 23/121: CHECK FOR STUCK THROTTLE PLATE		
<p>Service Code 23/121 indicates that the Throttle Position (TP) sensor's rotational setting may be out of Self-Test range (refer to Table #1).</p> <p>Possible causes are:</p> <ul style="list-style-type: none"> — Binding throttle linkage. — TP sensor may not be seated properly (tightened down). — Faulty TP sensor. — Faulty processor. <ul style="list-style-type: none"> • Visually inspect carburetor/throttle body and throttle linkage for binding or sticking. • Verify the throttle linkage is at mechanical/closed throttle. Check for: binding throttle linkage, speed control linkage, vacuum line/electrical harness interference, etc. • Does throttle move freely and return to closed throttle position? 		<p>Yes</p> <p>No</p>	<p>GO to DH3 .</p> <p>SERVICE as necessary. RERUN Quick Test.</p>

EEC-IV Pinpoint Test

TEST STEP		RESULT	ACTION TO TAKE
DH3	SERVICE CODE 53/112: ATTEMPT TO GENERATE CODE 63/122		
<p>Service Code 53 indicates that the Throttle Position (TP) sensor signal is greater than the Self-Test maximum value (refer to Table # 1).</p> <p>Possible causes are:</p> <ul style="list-style-type: none"> — TP sensor may not be seated properly (tightened down). — Faulty TP sensor. — Short to power in harness. — Faulty processor. • Key off. • Disconnect TP sensor. Inspect for damaged or pushed out pins, corrosion, loose wires, etc. Service as necessary. • Rerun Key On Engine Off Self-Test. • Is Code 63 or 122 present (ignore all other codes)? 		<p>Yes</p> <p>No</p>	<p>GO to DH4 .</p> <p>GO to DH6 .</p>
DH4	CHECK VREF CIRCUIT VOLTAGE		
<ul style="list-style-type: none"> • Key off. • TP sensor disconnected. • Both 4EAT module vehicle harness connectors disconnected (if applicable). • Key on, engine off. • Measure voltage between VREF circuit and SIG RTN circuit at the TP sensor vehicle harness connector. • Is voltage between 4.0 and 6.0 volts? 		<p>Yes</p> <p>No</p>	<p>REPLACE TP sensor. RERUN Quick Test.</p> <p>RECONNECT all components. GO to Pinpoint Test Step Go to PINPOINT TEST C, STEP C1.</p>

EEC-IV Pinpoint Test

TEST STEP		RESULT	ACTION TO TAKE
DH5	CHECK FOR SHORTED 4EAT MODULE		
<ul style="list-style-type: none"> • Key off. • Reconnect TP sensor. • Both 4EAT module vehicle harness connectors disconnected. • Rerun Key On Engine Off Self-Test. • Is code 53 or 123 present (ignore all other codes)? 		<p>Yes</p> <p>No</p>	<p>REPLACE TP sensor. RERUN Quick Test.</p> <p>Go to TRANSMISSIONS, CLUTCHES, DIFFERENTIALS, AXLES, AND DRIVE SHAFTS for 4EAT troubleshooting.</p>
DH6	CHECK TP CIRCUIT FOR SHORTS TO POWER		
<ul style="list-style-type: none"> • Key off. • TP sensor disconnected. • Disconnect processor 60 pin connector. Inspect for damaged or pushed out pins, corrosion, loose wires, etc. Service as necessary. • Install breakout box, leave processor disconnected. • Measure resistance between Test Pin 47 and Test Pins 26 and 57 at the breakout box. • Is each resistance greater than 10,000 ohms? 		<p>Yes</p> <p>No</p>	<p>REPLACE processor. REMOVE breakout box. RECONNECT TP sensor. RERUN Quick Test.</p> <p>SERVICE short circuit. REMOVE breakout box. RECONNECT all components. RERUN Quick Test.</p>

EEC-IV Pinpoint Test

TEST STEP		RESULT	ACTION TO TAKE
DH10	SERVICE CODE 63/122: ATTEMPT TO GENERATE CODE 53/123 OR 23/121		
	<p>Service Code 63/122 indicates that the Throttle Position (TP) sensor signal is less than the Self-Test minimum value (refer to Table #1).</p> <p>Possible causes are:</p> <ul style="list-style-type: none"> — TP sensor may not be seated properly (tightened down). — Faulty TP sensor. — Open harness. — Grounded harness. — Faulty processor. <ul style="list-style-type: none"> • Key off. • Disconnect TP sensor. Inspect for damaged or pushed out pins, corrosion, loose wires, etc. Service as necessary. • Jumper VREF circuit to TP circuit at TP sensor vehicle harness connector. • Perform Key On Engine Off Self-Test. <p>NOTE: If no codes are generated, immediately remove jumper and go directly to DH14.</p> <ul style="list-style-type: none"> • Is Code 53/123 or 23/121 present (ignore all other codes)? 	<p>Yes</p> <p>No</p>	<p>REPLACE TP sensor. REMOVE jumper. RERUN Quick Test.</p> <p>REMOVE jumper. GO to DH11 .</p>
DH11	CHECK VREF CIRCUIT VOLTAGE		
	<ul style="list-style-type: none"> • Key off. • TP sensor disconnected. • Key on engine off. • Measure voltage between VREF circuit and SIG RTN circuit at the TP sensor vehicle harness connector. • Is voltage between 4.0 and 6.0 volts? 	<p>Yes</p> <p>No</p>	<p>GO to DH12 . RECONNECT all components.</p> <p>RECONNECT all components. Go to PINPOINT TEST C, STEP C1.</p>

EEC-IV Pinpoint Test

TEST STEP		RESULT	ACTION TO TAKE
DH12	CHECK TP CIRCUIT CONTINUITY		
<ul style="list-style-type: none"> • Key off. • TP sensor disconnected. • Disconnect processor 60 pin connector. Inspect for damaged or pushed out pins, corrosion, loose wires, etc. Service as necessary. • Install breakout box and connect processor to breakout box. • Measure resistance between TP circuit at the TP sensor vehicle harness connector and Test Pin 47 at the breakout box. • Is the resistance less than 5.0 ohms? 		Yes No	GO to DH14 . SERVICE open circuit. REMOVE breakout box. RECONNECT all components. RERUN Quick Test.
DH13	CHECK FOR SHORTED 4EAT MODULE		
<p>NOTE: The 1.9L MA SEFI A/T and 3.0L Probe A/T vehicles have a TP circuit input to the 4EAT module. This Test is to verify that the TP circuit is not shorted inside the 4EAT module.</p> <ul style="list-style-type: none"> • Key off. • Reconnect TP sensor. • Disconnect both 4EAT module vehicle harness connectors. • Rerun Key On Engine Off Self-Test. • Is code 63 or 122 present (ignore all other codes)? 		Yes No	DISCONNECT TP sensor. GO to DH14 . Go to TRANSMISSIONS, CLUTCHES, DIFFERENTIALS, AXLES, AND DRIVE SHAFTS for 4EAT troubleshooting.
DH14	CHECK TP CIRCUIT FOR SHORTS TO GROUND		
<ul style="list-style-type: none"> • Key off. • TP sensor disconnected. • Both 4EAT module vehicle harness connectors disconnected (if applicable). • Disconnect processor 60 pin connector. Inspect for damaged or pushed out pins, corrosion, loose wires, etc. Service as necessary. • Install breakout box, leave processor disconnected. • Measure resistance between Test Pin 47 and Test Pins 40, 46, and 60 at the breakout box. • Is each resistance greater than 10,000 ohms? 		Yes No	REPLACE processor. REMOVE breakout box. RECONNECT all components. RERUN Quick Test. SERVICE short circuit. REMOVE breakout box. RECONNECT all components. RERUN Quick Test.

EEC-IV Pinpoint Test

TEST STEP		RESULT	ACTION TO TAKE
DH20	ENGINE RUNNING SERVICE CODE 73/167: PERFORM PROPER DYNAMIC RESPONSE TEST AT WIDE OPEN THROTTLE		
<p>NOTE: Engine Running Service Code 73/167 indicates the TP sensor did not exceed 25 percent of its rotation during the Dynamic Response Test. A complete wide open throttle must be performed during the Dynamic Response portion of the test.</p> <ul style="list-style-type: none"> • Run Key On Engine Running Self-Test. Be sure a complete WOT is performed during the Dynamic Response portion of the test. • Is Code 73 or 167 still present? 		<p>Yes</p> <p>No</p>	<p>GO to DH21 .</p> <p>Unable to duplicate Code 73/167 at this time.Service other Engine Running Codes. Otherwise, testing completed.</p>
DH21	CHECK TP SENSOR MOVEMENT DURING DYNAMIC RESPONSE TEST		
<ul style="list-style-type: none"> • Key off. • Disconnect processor 60 pin connector. Inspect for damaged or pushed out pins, corrosion, loose wires, etc. Service as necessary. • Install breakout box and connect processor to breakout box. • Connect DVOM to Test Pin 47 and Test Pin 46 at the breakout box. • Rerun Engine Running Self-Test with a proper WOT Dynamic Response portion of the test. • Does voltage increase to greater than 3.5 volts during the Dynamic Response Test? 		<p>Yes</p> <p>No</p>	<p>REPLACE processor. REMOVE breakout box. RERUN Quick Test.</p> <p>VERIFY TP sensor is properly installed to throttle body. If OK, REPLACE TP sensor. RERUN Quick Test.</p>

EEC-IV Pinpoint Test

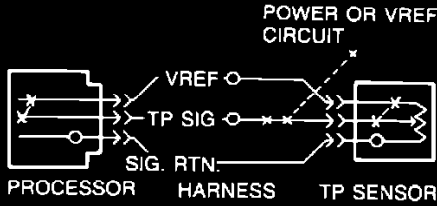
TEST STEP		RESULT	ACTION TO TAKE
DH90	<p>CONTINUOUS MEMORY CODE 53/123: MONITOR TP CIRCUIT UNDER SIMULATED ROAD SHOCK</p> <ul style="list-style-type: none"> • Enter Key On Engine Off Continuous Monitor mode. (Refer to TESTING PROCEDURES/QUICK TEST AND DIAGNOSTIC AIDS/DETAILED QUICK TEST PROCEDURES/CONTINUOUS MEMORY CODES) • Observe VOM or STAR LED for indication of a fault while performing the following: <ul style="list-style-type: none"> — Move throttle slowly to WOT position. — Release throttle slowly to closed position and lightly tap on TP sensor (simulate road shock). — Wiggle TP harness connector. • Does VOM or STAR LED indicate a fault? 	<p>Yes</p> <p>No</p>	<p>GO to DH91 .</p> <p>GO to DH92 .</p>
DH91	<p>MEASURE THROTTLE POSITION SIGNAL VOLTAGE WHILE EXERCISING TP SENSOR</p> <ul style="list-style-type: none"> • Key off. • Disconnect processor 60 pin connector. Inspect for damaged or pushed out pins, corrosion, loose wires, etc. Service as necessary. • Install breakout box and connect processor to breakout box. • VOM or STAR LED still connected to STO as in previous step. • Connect a DVOM from Test Pin 47 to Test Pin 46 at the breakout box. • Key on, engine off. • While observing DVOM, repeat Step DH90 . • Does the fault occur below 4.25 volts? 	<p>Yes</p> <p>No</p>	<p>DISCONNECT and INSPECT connector. If connector and terminals are good, REPLACE TP sensor. CLEAR Continuous Memory Codes. RERUN Quick Test. (Refer to TESTING PROCEDURES/QUICK TEST AND DIAGNOSTIC AIDS/DETAILED QUICK TEST PROCEDURES/CONTINUOUS MEMORY CODES for code clearing procedures.) (Refer to TESTING PROCEDURES/QUICK TEST AND DIAGNOSTIC AIDS/DETAILED QUICK TEST PROCEDURES/KEY ON ENGINE OFF SELF TEST for quick test procedures)</p> <p>Throttle position sensor overtravel may have caused the Continuous Memory Code 53/123. VERIFY vehicle harness integrity, GO to DH92 .</p>

EEC-IV Pinpoint Test

TEST STEP		RESULT	ACTION TO TAKE
DH92	CHECK EEC-IV VEHICLE HARNESS	Yes	ISOLATE fault. SERVICE as necessary. REFER to appropriate figure. CLEAR Continuous Memory (Refer to TESTING PROCEDURES/QUICK TEST AND DIAGNOSTIC AIDS/DETAILED QUICK TEST PROCEDURES/CONTINUOUS MEMORY CODES. RERUN Quick Test.
	<ul style="list-style-type: none"> • Still in Key On Engine Off Continuous Monitor mode. • Observe VOM or STAR LED for a fault indication while performing the following: <ul style="list-style-type: none"> — Referring to the illustration in Step DH90 , grasp the vehicle harness close to the sensor connector. Wiggle, shake or bend a small section of the EEC-IV system vehicle harness while working your way to the dash panel. Also wiggle, shake or bend the EEC-IV vehicle harness from the dash panel to the processor. • Does VOM or STAR LED indicate a fault? 	No	GO to DH93 .
DH93	CHECK PROCESSOR AND HARNESS CONNECTORS	No	SERVICE as necessary. CLEAR Continuous Memory . (Refer to TESTING PROCEDURES/QUICK TEST AND DIAGNOSTIC AIDS/DETAILED QUICK TEST PROCEDURES/CONTINUOUS MEMORY CODES) RERUN Quick Test.
	<ul style="list-style-type: none"> • Key off. • Disconnect processor 60 pin connector. Inspect for damaged or pushed out pins, corrosion, loose wires, etc. Service as necessary. • Are connectors and terminals OK? 	Yes	Unable to duplicate and/or identify fault at this time. For further diagnosis using the EEC-IV Monitor box, Refer to TESTING PROCEDURES/QUICK TEST AND DIAGNOSTIC AIDS/INTERMITTENT FAULT DIAGNOSIS. All others, CLEAR Continuous Memory (Refer to TESTING PROCEDURES/QUICK TEST AND DIAGNOSTIC AIDS/DETAILED QUICK TEST PROCEDURES/CONTINUOUS MEMORY CODES) RERUN Quick Test.

EEC-IV Pinpoint Test

TEST STEP		RESULT	ACTION TO TAKE
DH94	CONTINUOUS MEMORY CODE 63/122: MONITOR TP CIRCUIT UNDER SIMULATED ROAD SHOCK		
	<ul style="list-style-type: none"> Enter Key On Engine Off Continuous Monitor mode. Refer to Quick Test Appendix. Observe VOM or STAR LED for indication of a fault while performing the following: <ul style="list-style-type: none"> Move throttle slowly to WOT position. Release throttle slowly to closed position. Lightly tap on TP sensor (simulate road shock). Wiggle TP harness connector. Does VOM or STAR LED indicate a fault? 	<p>Yes</p> <p>No</p>	<p>INSPECT connectors. If connectors and terminals are good, REPLACE TP sensor, REFER to Fuel/Engine Shop Manual Group. CLEAR Continuous Memory.(Refer to TESTING PROCEDURES/QUICK TEST AND DIAGNOSTIC AIDS/DETAILED QUICK TEST PROCEDURES/CONTINUOUS MEMORY CODES) RERUN Quick Test.</p> <p>GO to DH95 .</p>
	<p>The diagram illustrates the electrical connection between the TP sensor, the vehicle harness, and the processor. The TP sensor has three terminals: VREF, TP SIG, and SIG. RTN. The VREF terminal is connected to a power source (represented by a battery symbol) through a resistor. The TP SIG terminal is connected to the processor and also to ground through a resistor. The SIG. RTN terminal is connected to the processor and also to ground through a resistor. The processor is shown as a multi-pin connector on the left, and the TP sensor is shown as a multi-pin connector on the right. The harness connects the two.</p>		
DH95	CHECK EEC-IV VEHICLE HARNESS		
	<ul style="list-style-type: none"> Still in Key On Engine Off Continuous Monitor mode. Observe VOM or STAR LED for a fault indication while performing the following: <ul style="list-style-type: none"> Referring to the illustration in Step DH94 grasp the vehicle harness close to the sensor connector. Wiggle, shake or bend a small section of the EEC-IV system vehicle harness while working your way to the dash panel. Also wiggle, shake or bend the EEC-IV vehicle harness from the dash panel to the processor. Does VOM or STAR LED indicate a fault? 	<p>Yes</p> <p>No</p>	<p>ISOLATE fault. SERVICE as necessary . REFER to appropriate figure. CLEAR Continuous Memory. (Refer to TESTING PROCEDURES/QUICK TEST AND DIAGNOSTIC AIDS/DETAILED QUICK TEST PRECEDURES/CONTINUOUS MEMORY CODES) RERUN Quick Test.</p> <p>GO to DH96 .</p>

EEC-IV Pinpoint Test

TEST STEP		RESULT	ACTION TO TAKE
DH96	CHECK PROCESSOR AND HARNESS CONNECTORS	No	SERVICE as necessary. CLEAR Continuous Memory. (Refer to TESTING PROCEDURES/QUICK TEST AND DIAGNOSTIC AIDS/DETAILED QUICK TEST PROCEDURES/CONTINUOUS MEMORY CODES) RERUN Quick Test.
	<ul style="list-style-type: none"> • Key off. • Disconnect processor 60 pin connector. Inspect for damaged or pushed out pins, corrosion, loose wires, etc. • Are connectors and terminals OK? 	Yes	<p>Unable to duplicate and/or identify fault at this time. For further diagnosis using the EEC-IV Monitor box, Refer to TESTING PROCEDURES/QUICK TEST AND DIAGNOSTIC AIDS/INTERMITTENT FAULT DIAGNOSIS.</p> <p>All others, CLEAR Continuous Memory (Refer to TESTING PROCEDURES/QUICK TEST AND DIAGNOSTIC AIDS/DETAILED QUICK TEST PROCEDURES/CONTINUOUS MEMORY CODES) RERUN Quick Test.</p>

EEC-IV Pinpoint Test

Note

You should enter this Pinpoint Test only when you have been directed here from Quick Test or from Pinpoint Test Step S8.

Remember

To prevent the replacement of good components, be aware that the following non-EEC area may be at fault:

- Damaged EGR valve

This Pinpoint Test is intended to diagnose only the following:

- EVP sensor (-9G428-)
- Harness circuits: VREF, EVP, SIG RTN, EVR, VPWR
- EVR Solenoid (-9J459-)
- EGR valve assembly
- Processor assembly (-12A650-)
- EGR and EVR vacuum lines

Pinpoint Test Schematic

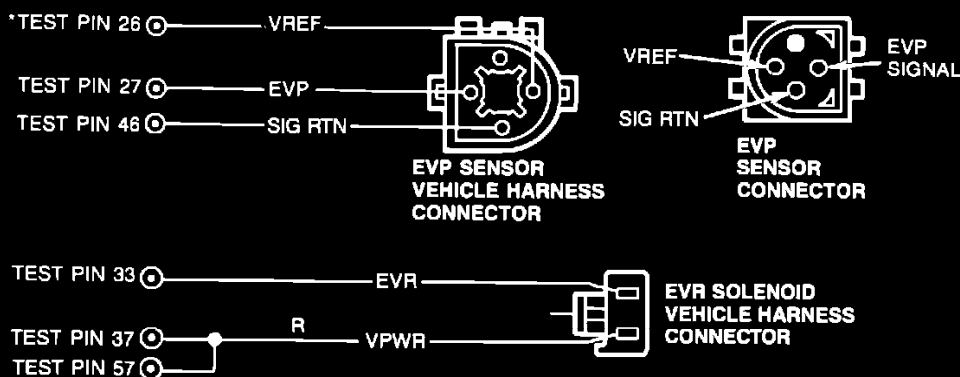

*TEST PINS LOCATED ON BREAKOUT BOX.
ALL HARNESS CONNECTORS VIEWED INTO MATING SURFACE.

EEC-IV Pinpoint Test

Test Pin 46		SIG RTN	
Application		Wire Color	
All		GY/R	

Test Pin 26		VREF	
Application		Wire Color	
All		BR/W	

Test Pin 33		EVR	
Application		Wire Color	
All		BR/PK	

Test Pin 27		EVP	
Application		Wire Color	
All		BR/LG	

EEC-IV Pinpoint Test

TEST STEP		RESULT	ACTION TO TAKE
DN1	SERVICE CODE 31/327: ATTEMPT TO GENERATE CODE 35/337		
	Service Code 31/327 indicates that the EGR Valve Position (EVP) sensor signal is less than the Self-Test minimum value of 0.2 volts. Possible causes are: — Faulty EVP sensor. — Open harness. — Grounded harness. — Faulty processor. • Key off. • Disconnect EVP sensor. • Jumper VREF circuit to EVP circuit at the EVP sensor vehicle harness connector. • Rerun Key On Engine Off Self-Test. • Is Code 35 or 337 present (ignore all other codes)?	Yes No	REPLACE EVP sensor. REMOVE Jumper. RERUN Quick Test. REMOVE Jumper. GO to DN2 .
DN2	CHECK VREF CIRCUIT VOLTAGE		
	• Key on, engine off. • EVP sensor disconnected. • Measure voltage between VREF circuit and SIG RTN circuit at the EVP sensor vehicle harness connector. • Is voltage between 4.0 and 6.0 volts?	Yes No	GO to DN3 . GO to Pinpoint Test C, STEP C1.
DN3	CHECK EVP CIRCUIT CONTINUITY		
	• Key off, wait 10 seconds. • EVP sensor disconnected. • Disconnect processor 60 pin connector. Inspect for damaged or pushed out pins, corrosion, loose wires, etc. Service as necessary. • Install breakout box and connect processor to breakout box. • Measure resistance between EVP circuit at the EVP sensor vehicle harness connector and Test Pin 27 at the breakout box. • Is resistance less than 5 ohms?	Yes No	GO to DN4 . SERVICE open circuit. REMOVE breakout box. RECONNECT all components. RERUN Quick Test.

EEC-IV Pinpoint Test

TEST STEP		RESULT	ACTION TO TAKE
DN4	CHECK EVP CIRCUIT FOR SHORT TO GROUND		
	<ul style="list-style-type: none"> • Key off. • EVP sensor disconnected. • Breakout box installed. • Disconnect processor. • Measure resistance between Test Pin 27 and Test Pins 40, 46 and 60 at the breakout box. • Is each resistance greater than 10,000 ohms? 	<p>Yes</p> <p>No</p>	<p>REPLACE processor. REMOVE breakout box. RECONNECT all components. RERUN Quick Test.</p> <p>SERVICE short circuit. REMOVE breakout box. RECONNECT all components. RERUN Quick Test.</p>
DN5	SERVICE CODE 35/337: ATTEMPT TO GENERATE CODE 31/327		
	<p>Service Code 35/337 indicates that the EGR Valve Position (EVP) sensor signal is greater than the Self-Test maximum value of 4.81 volts.</p> <p>Possible causes are:</p> <ul style="list-style-type: none"> — Faulty EVP sensor. — Short to power in harness. • Key off, wait 10 seconds. • Disconnect EVP sensor. • Rerun Key On Engine Off Self-Test. • Is Code 31 or 327 present (ignore all other codes)? 	<p>Yes</p> <p>No</p>	<p>GO to DN6 .</p> <p>GO to DN7 .</p>
DN6	CHECK VREF CIRCUIT VOLTAGE		
	<ul style="list-style-type: none"> • Key on, engine off. • EVP sensor disconnected. • Measure voltage between VREF circuit and SIG RTN circuit at the EVP sensor vehicle harness connector. • Is voltage between 4.0 and 6.0 volts? 	<p>Yes</p> <p>No</p>	<p>REPLACE EVP sensor. RERUN Quick Test.</p> <p>RECONNECT all components. Go to PINPOINT TEST C, STEP C1.</p>

EEC-IV Pinpoint Test

TEST STEP		RESULT	ACTION TO TAKE								
DN7	CHECK EVP CIRCUIT FOR SHORT TO POWER										
<ul style="list-style-type: none"> • Key off. • EVP sensor disconnected. • Disconnect processor 60 pin connector. Inspect for damaged or pushed out pins, corrosion, loose wires, etc. Service as necessary. • Install breakout box, leave processor disconnected. • DVOM on 200,000 ohm scale. • Measure the resistance between Test Pin 27 and Test Pins 26 and 57 at the breakout box. • Is each resistance greater than 10,000 ohms? 		<p>Yes</p> <p>No</p>	<p>REPLACE processor. REMOVE breakout box. RECONNECT EVP sensor. RERUN Quick Test.</p> <p>SERVICE short circuit. REMOVE breakout box. RECONNECT all components. RERUN Quick Test.</p>								
DN10	SERVICE CODE 84/558: CHECK RESISTANCE OF EVR										
<p>Service Code 84/558 indicates a failure in the EGR Vacuum Regulator (EVR) solenoid circuit.</p> <p>Possible causes are:</p> <ul style="list-style-type: none"> — Faulty EVR solenoid — Open harness — Shorted harness — Faulty processor <ul style="list-style-type: none"> • Key off. • Disconnect EVR solenoid. • DVOM on 200 ohm scale. • Measure solenoid resistance. • Is resistance within specification per the following chart? <table border="1" style="margin-left: 20px;"> <thead> <tr> <th>Engine</th> <th>Resistance Specification</th> </tr> </thead> <tbody> <tr> <td>4.9L and 5.8L U/8500</td> <td>20 to 45 ohms</td> </tr> <tr> <td>7.5L</td> <td>100 to 135 ohms</td> </tr> <tr> <td>All Others</td> <td>30 to 70 ohms</td> </tr> </tbody> </table>		Engine	Resistance Specification	4.9L and 5.8L U/8500	20 to 45 ohms	7.5L	100 to 135 ohms	All Others	30 to 70 ohms	<p>Yes</p> <p>No</p>	<p>GO to DN11 .</p> <p>REPLACE EVR solenoid assembly. RERUN Quick Test.</p>
Engine	Resistance Specification										
4.9L and 5.8L U/8500	20 to 45 ohms										
7.5L	100 to 135 ohms										
All Others	30 to 70 ohms										
DN11	CHECK VPWR CIRCUIT VOLTAGE										
<ul style="list-style-type: none"> • Key on, engine off. • EVR solenoid disconnected. • DVOM on 20 volt scale. • Measure voltage between battery negative post and VPWR circuit at the EVR solenoid vehicle harness connector. • Is voltage greater than 10.5 volts? 		<p>Yes</p> <p>No</p>	<p>GO to DN12 .</p> <p>SERVICE open circuit. RECONNECT EVR solenoid. RERUN Quick Test.</p>								

EEC-IV Pinpoint Test

TEST STEP		RESULT	ACTION TO TAKE
DN12	CHECK EVR CIRCUIT CONTINUITY		
<ul style="list-style-type: none"> • Key off. • EVR solenoid disconnected. • Disconnect processor 60 pin connector. Inspect for damaged or pushed out pins, corrosion, loose wires, etc. Service as necessary. • Install breakout box, leave processor disconnected. • DVOM on 200 ohm scale. • Measure resistance between Test Pin 33 at the breakout box and EVR circuit at the EVR solenoid vehicle harness connector. • Is resistance less than 5 ohms? 		<p>Yes ▶</p> <p>No ▶</p>	<p>GO to DN13 .</p> <p>SERVICE open circuit. REMOVE breakout box. RECONNECT all components. RERUN Quick Test.</p>
DN13	CHECK EVR CIRCUIT FOR SHORT TO POWER OR GROUND		
<ul style="list-style-type: none"> • Key off. • EVR solenoid disconnected. • Breakout box installed, processor disconnected. • DVOM on 200,000 ohm scale. • Measure resistance between Test Pin 33 and Test Pins 37 and 57 at the breakout box. • Measure resistance between Test Pin 33 and Test Pin 40, 46 and 60 at the breakout box. • Is each resistance greater than 10,000 ohms? 		<p>Yes ▶</p> <p>No ▶</p>	<p>REPLACE processor. REMOVE breakout box. RECONNECT EVR solenoid. RERUN Quick Test.</p> <p>SERVICE short circuit. REMOVE breakout box. RECONNECT all components. RERUN Quick Test. (Refer to TESTING PROCEDURES/QUICK TEST AND DIAGNOSTIC AIDS/DETAILED QUICK TEST PROCEDURES/KEY ON ENGINE OFF SELF TEST for quick test procedures). If code is repeated, REPLACE EVR solenoid.</p>

EEC-IV Pinpoint Test

TEST STEP		RESULT	ACTION TO TAKE
DN20	SERVICE CODE 34/334: CHECK FOR SERVICE CODE 84/558		
<p>Service Code 34/334 in Key On Engine Off indicates that the EGR valve and/or EGR Valve Position (EVP) sensor is not fully seated in the closed position. The EVP sensor voltage is greater than the closed limit voltage of 0.67 volts. Because of the preload on the installed EVP sensor, it is very difficult to determine whether the EGR valve is seated or the EVP sensor is in contact with the EGR valve stem.</p> <p>Possible causes are:</p> <ul style="list-style-type: none"> — Poor continuity at EVP sensor. — Non-seated EGR valve. — Faulty EGR valve. — Faulty EVP sensor. <ul style="list-style-type: none"> • Key off. • Is Code 84 or 558 present in Key On Engine Off Self-Test? 		<p>Yes</p> <p>No</p>	<p>GO to DN10 .</p> <p>GO to DN21 .</p>
DN21	CHECK EVP SENSOR AND EGR VALVE OPERATION		
<ul style="list-style-type: none"> • Key off. • Disconnect EVP sensor. • Inspect both the connector on harness and sensor for damaged pins, corrosion, loose wires, etc. Service as necessary. • Remove vacuum line from EGR valve. • Exercise EGR valve by either applying and releasing vacuum with a vacuum pump or depressing and releasing the diaphragm manually. • Reconnect vacuum line to EGR valve and electrical connector to EVP sensor. • Rerun Key On Engine Off and Engine Running Self-Test. • Is Code 34 or 334 still present? 		<p>Yes</p> <p>No</p>	<p>GO to DN22 .</p> <p>The original Code 34/334 was the result of poor continuity at the EVP sensor connector or binding of the EGR valve stem by contaminants. Testing complete.</p>

EEC-IV Pinpoint Test

TEST STEP		RESULT	ACTION TO TAKE
DN22	CHECK EVR SOLENOID OPERATION	Yes	REMOVE vacuum gauge. GO to DN23
	<ul style="list-style-type: none"> • Key off. • Install vacuum gauge to EGR valve vacuum hose. • Start engine. • Is vacuum less than 2.5 in-Hg to the EGR valve at normal operating temperature? 	No	The original Code 34/334 was the result of the EVR solenoid stuck open. REPLACE EVR solenoid. RERUN Quick Test. (Refer to TESTING PROCEDURES/QUICK TEST AND DIAGNOSTIC AIDS/DETAILED QUICK TEST PROCEDURES/KEY ON ENGINE OFF SELF TEST for quick test procedures).
DN23	SUBSTITUTE EVP SENSOR ON ORIGINAL EGR VALVE	Yes	Go to EMISSION CONTROLS for EGR valve diagnosis.
	<ul style="list-style-type: none"> • Key off, wait 10 seconds. • Install a known good EVP sensor on original EGR valve. • Perform Key On Engine Off Quick Test. • Is Code 34 or 334 still present? 	No	The original Code 34/334 was the result of the original EVP sensor. SERVICE EVP sensor as necessary. RERUN Quick Test.

EEC-IV Pinpoint Test

TEST STEP		RESULT	ACTION TO TAKE
DN25	SERVICE CODE 32/328: CHECK EVP SENSOR AND EGR VALVE OPERATION		
<p>Service Code 32/328 in Key On Engine Off and Key On Engine Running indicates that the EGR valve and/or EVP sensor voltage is lower than normal in the closed position. The EVP voltage is less than the closed limit voltage of 0.29 volts. Because of the preload of the EVP sensor it is very difficult to determine whether the EGR valve has malfunctioned or the EVP sensor has an abnormally high resistance.</p> <p>Possible causes are:</p> <ul style="list-style-type: none"> — Poor continuity at EVP sensor connector. — Non-seated EGR valve. — Faulty EGR valve. — Faulty EVP sensor. <ul style="list-style-type: none"> • Key off. • Disconnect EVP sensor. • Inspect both the connector at harness and sensor for damaged pins, corrosion, loose wires, etc. Service as necessary. • Remove vacuum line from EGR valve. • Exercise EGR valve by either applying and releasing vacuum with a vacuum pump or depressing and releasing the diaphragm manually. • Reconnect vacuum line to EGR valve and electrical connector to EVP sensor. • Rerun Key On Engine Off and Engine Running Self-Test. (Refer to TESTING PROCEDURES/QUICK TEST AND DIAGNOSTIC AIDS/DETAILED QUICK TEST PROCEDURES/KEY ON ENGINE OFF SELF TEST and ENGINE RUNNING SELF TEST for test procedures) • Is Code 32 or 328 still present? 		<p>Yes</p> <p>No</p>	<p>▶ GO to DN26 .</p> <p>▶ The original Code 32/328 was the result of poor continuity at the EVP sensor connector or binding of the EGR valve stem by contaminants. Testing complete.</p>
DN26	SUBSTITUTE EVP SENSOR ON ORIGINAL EGR VALVE		
<ul style="list-style-type: none"> • Key off. • Install a known good EVP sensor on original EGR valve. • Rerun Key On Engine Off Self-Test. <p>(Refer to TESTING PROCEDURES/QUICK TEST AND DIAGNOSTIC AIDS/DETAILED QUICK TEST PROCEDURES/KEY ON ENGINE OFF SELF TEST for quick test procedures.)</p> <ul style="list-style-type: none"> • Is Code 32 or 338 present? 		<p>Yes</p> <p>No</p>	<p>▶ GO to EMISSION CONTROLS for EGR valve diagnosis.</p> <p>▶ The original Code 32/328 was the result of the original EVP sensor. SERVICE EVP sensor as necessary. RERUN Quick Test.</p>

EEC-IV Pinpoint Test

TEST STEP		RESULT	ACTION TO TAKE
DN40	SERVICE CODE 33/332: VERIFY VACUUM IS PRESENT AT EGR VALVE		
<p>Service Code 33/332 in Key On Engine Running indicates that the EVP sensor input did not change after the EVR solenoid was instructed by the processor to open the EGR valve. Because a Code 84 was not received in the Key On Engine Off Self-Test, it is known that the EVR solenoid functions electrically. It is also known that the EVP sensor is in the expected closed valve range because Code 32/328 and 34/334 were not received in either Key On Engine Off or Key On Engine Running Tests.</p> <p>Possible causes are:</p> <ul style="list-style-type: none"> — Vacuum hose leaks — Obstructed vacuum hose — Obstructed EVR solenoid filter — Faulty EGR valve • Key off. • Disconnect vacuum line from EGR valve. • Connect vacuum gauge at open vacuum line. • Rerun Engine Running Self-Test while observing vacuum gauge. • Is vacuum greater than 1.5 in-Hg (5 kPa)? 		<p>Yes</p> <p>No</p>	<p>REMOVE vacuum gauge. GO to DN43 .</p> <p>REMOVE vacuum gauge. RECONNECT EGR valve vacuum line. GO to DN41 .</p>
DN41	VERIFY VACUUM SUPPLY TO EVR SOLENOID		
<ul style="list-style-type: none"> • Key off. • Disconnect the vacuum source to the EVR solenoid. • Install a vacuum gauge at source vacuum. • Start engine and check vacuum. • Is vacuum greater than 10 in-Hg (33 kPa)? 		<p>Yes</p> <p>No</p>	<p>GO to DN42 .</p> <p>CHECK source vacuum hose to EVR solenoid. SERVICE as necessary. RERUN Quick Test. (Refer to TESTING PROCEDURES/QUICKTEST AND DIAGNOSTIC AIDS/DETAILED QUICK TEST PROCEDURES/KEY ON ENGINE OFF SELF TEST for quick test procedures).</p>

EEC-IV Pinpoint Test

TEST STEP		RESULT	ACTION TO TAKE
DN42	CHECK VACUUM HOSE BETWEEN EVR SOLENOID AND EGR VALVE		
	<ul style="list-style-type: none"> Carefully check EGR vacuum hose from EGR valve to EVR solenoid for obstructions, cracks, loose connectors, blockage, kinks, leaks, etc. Is vacuum hose in good condition? 	<p>Yes</p> <p>No</p>	<p>CHECK EVR solenoid filter for obstructions. REPLACE as necessary. If OK, REPLACE EVR solenoid assembly. RECONNECT vacuum hose. RERUN Quick Test. (Refer to TESTING PROCEDURES/QUICKTEST AND DIAGNOSTIC AIDS/DETAILED QUICK TEST PROCEDURES/KEY ON ENGINE OFF SELF TEST for quick test procedures).</p> <p>SERVICE vacuum hose as necessary. RERUN Quick Test. (Refer to TESTING PROCEDURES/QUICKTEST AND DIAGNOSTIC AIDS/DETAILED QUICK TEST PROCEDURES/KEY ON ENGINE OFF SELF TEST for quick test procedures).</p>
DN43	CHECK EVP SENSOR AND EGR VALVE OPERATION		
	<ul style="list-style-type: none"> Key off. Disconnect EVP sensor. Inspect both the connector at harness and sensor for damaged pins, corrosion, loose wires, etc. Service as necessary. EGR valve vacuum line disconnected. Exercise EGR valve by either applying and releasing vacuum with a vacuum pump or depressing and releasing the diaphragm manually. Reconnect vacuum line to EGR valve and electrical connector to EVP sensor. Rerun Key On Engine Off and Engine Running Self-Test. Is Code 33 or 332 still present? 	<p>Yes</p> <p>No</p>	<p>GO to DN44 .</p> <p>The original Code 33/332 was the result of poor continuity at the EVP signal connector or binding of the EGR valve stem by contaminants. SERVICE as necessary. Testing complete.</p>
DN44	VERIFY EGR VALVE VACUUM CONTROL		
	<ul style="list-style-type: none"> Key off. EGR valve vacuum disconnected. Connect vacuum gauge to EGR valve, and apply 2 to 3 in-Hg (6.7 to 10 kPa) for 2 minutes. Does EGR valve hold vacuum? 	<p>Yes</p> <p>No</p>	<p>RECONNECT EGR valve (vacuum), GO to DN45 .</p> <p>Go to EMISSION CONTROLS for EGR valve diagnosis.</p>

EEC-IV Pinpoint Test

TEST STEP		RESULT	ACTION TO TAKE
DN45	SUBSTITUTE KNOWN GOOD EVP SENSOR ON ORIGINAL EGR VALVE	Yes	Go to EMISSION CONTROLS for EGR valve diagnosis.
	<ul style="list-style-type: none"> • Key off. • Install a known good EVP sensor on original EGR valve. • Rerun Engine Running Self-Test. (Refer to TESTING PROCEDURES/QUICKTEST AND DIAGNOSTIC AIDS/DETAILED QUICK TEST PROCEDURES/KEY ON ENGINE OFF SELF TEST and ENGINE RUNNING SELF TEST for test procedures). <ul style="list-style-type: none"> • Is Code 33 or 332 present? 	No	The original Code 33/332 was the result of the original EVP sensor. SERVICE EVP sensor as necessary. RERUN Quick Test. (Refer to TESTING PROCEDURES/QUICKTEST AND DIAGNOSTIC AIDS/DETAILED QUICK TEST PROCEDURES/KEY ON ENGINE OFF SELF TEST for quick test procedures).
DN50	SERVICE CODE 34/334: CHECK EGR VALVE OPERATION IN ENGINE RUNNING SELF-TEST WITH EGR VACUUM DISCONNECTED	Yes	GO to DN51 .
	Service Code 34/334 in Key On Engine Runni indicates that the EVP sensor voltage is greater than the closed limit voltage of 0.67 volts. ^{3r} Possible causes are: — Obstructed EVR solenoid filter — Faulty EVR solenoid — Faulty EGR valve — Faulty EVP sensor <ul style="list-style-type: none"> • Key off. • Disconnect vacuum hose from EGR valve and plug hose. • Rerun Engine Running Self-Test. (Refer to TESTING PROCEDURES/QUICK TEST AND DIAGNOSTIC AIDS/DETAILED QUICK TEST PROCEDURES/KEY ON ENGINE OFF SELF TEST and ENGINE RUNNING SELF TEST for quick test procedures) • Is Code 34 or 334 present? 	No	CHECK EVR solenoid filter for obstructions. REPLACE as necessary. If OK, REPLACE EVR solenoid assembly. RECONNECT all vacuum hoses. RERUN Quick Test. (Refer to TESTING PROCEDURES/QUICKTEST AND DIAGNOSTIC AIDS/DETAILED QUICK TEST PROCEDURES/KEY ON ENGINE OFF SELF TEST for quick test procedures).
DN51	CHECK EVP SENSOR RESISTANCE WHILE APPLYING VACUUM TO EGR VALVE	Yes	Go to EMISSION CONTROLS for EGR valve diagnosis.
	<ul style="list-style-type: none"> • Key off, wait 10 seconds. • Disconnect EVP sensor. • Disconnect vacuum hose at EGR valve. • Connect vacuum pump to EGR valve. • Measure resistance between EVP circuit and VREF circuit at the EVP sensor while increasing vacuum to 10 in-Hg (33 kPa). • Observe resistance as vacuum increases. • Does resistance decrease gradually from no more than 5,500 ohms to no less than 100 ohms? 	No	REPLACE EVP sensor. RECONNECT vacuum hose. RERUN Quick Test. (Refer to TESTING PROCEDURES/QUICKTEST AND DIAGNOSTIC AIDS/DETAILED QUICK TEST PROCEDURES/KEY ON ENGINE OFF SELF TEST for quick test procedures).

EEC-IV Pinpoint Test

TEST STEP		RESULT	ACTION TO TAKE
DN90	CONTINUOUS MEMORY CODE 32/328: CHECK EVP SIGNAL VOLTAGE WHILE EXERCISING EVP SENSOR	Yes	EGR valve may have caused Continuous Memory Code 32/328. CLEAR Continuous Memory (Refer to TESTING PROCEDURES/QUICK TEST AND DIAGNOSTIC AIDS/DETAILED AIDS/DETAILED QUICK TEST PROCEDURES/CONTINUOUS MEMORY CODES for procedures). Go to EMISSION CONTROLS for EGR valve diagnosis.
	<p>Continuous Memory Code 32/328 indicates that the EGR valve was closed further than normal with the engine at stabilized operating temperature and at idle, or that the EVP sensor has failed with an intermittent low voltage spike symptom.</p> <p>Possible causes are:</p> <ul style="list-style-type: none"> — Faulty EVP sensor. — Faulty EGR valve. — Obstructed vacuum hose. <ul style="list-style-type: none"> • Key off. • Disconnect processor 60 pin connector. Inspect for damaged or pushed out pins, corrosion, loose wires, etc. Service as necessary. • Install breakout box and connect processor to breakout box. • Disconnect vacuum hose at EGR valve. • Connect a vacuum pump to the EGR valve. • Key on, engine off. • Measure voltage between Test Pin 27 and Test Pin 46 at the breakout box while doing the following: <ul style="list-style-type: none"> — Slowly increase vacuum at EGR valve to 6 in-Hg (20 kPa), then slowly bleed vacuum off the EGR valve and lightly tap on EVP sensor (simulate road shock). • Does voltage drop to less than 0.24 volts? 	No	GO to DN91 .

EEC-IV Pinpoint Test

TEST STEP		RESULT	ACTION TO TAKE
DN91	CONTINUOUS MEMORY CODE 32/31(328/327); CHECK EVP SENSOR WHILE IN CONTINUOUS MONITOR MODE		
<p>Continuous Memory Code 31/327 indicates that sometime during vehicle operation, the EVP signal was out of Self-Test range.</p> <p>Possible causes are:</p> <ul style="list-style-type: none"> — Open or shorted circuit. — Faulty EVP sensor. <ul style="list-style-type: none"> • Enter Key On Engine Off Continuous Monitor mode. (Refer to TESTING PROCEDURES/QUICK TEST AND DIAGNOSTIC AIDS/DETAILED QUICK TEST PROCEDURES/CONTINUOUS MEMORY CODES for procedures.) • Observe VOM or STAR LED for indication of a fault while performing the following: <ul style="list-style-type: none"> • Connect a vacuum pump to the EGR valve. • Very slowly apply 20 kPa (6 in-Hg) vacuum to the EGR valve. • Slowly bleed vacuum off the EGR valve. Lightly tap on EVP sensor (simulate road shock). • Wiggle EVP sensor connector. • Is a fault indicated? 		<p>Yes</p> <p>No</p>	<p>GO to DN92 .</p> <p>GO to DN93 .</p>
 <p style="text-align: center;">PROCESSOR HARNESS EVP SENSOR</p>			
DN92	MEASURE EVP SIGNAL VOLTAGE WHILE EXERCISING EVP SENSOR		
<ul style="list-style-type: none"> • Key off. • Disconnect processor 60 pin connector. Inspect for damaged or pushed out pins, corrosion, loose wires, etc. Service as necessary. • Install breakout box and connect processor to breakout box. • Connect a DVOM between Test Pin 27 and Test Pin 46 at the breakout box. • Re-enter Key On Engine Off Continuous Monitor mode. • While observing DVOM, repeat Test Step DN91 . • Does the fault occur below 4.25 volts? 		<p>Yes</p> <p>No</p>	<p>DISCONNECT and INSPECT connector. If connector and terminals are good, REPLACE EVP sensor. CLEAR Continuous Memory (Refer to TESTING PROCEDURES/QUICK TEST AND DIAGNOSTIC AIDS/DETAILED QUICK TEST PROCEDURES/CONTINUOUS MEMORY CODES for procedures.) RERUN Quick Test.</p> <p>GO to DN93 .</p>

EEC-IV Pinpoint Test

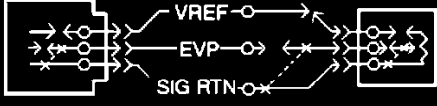
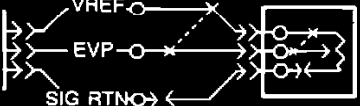
TEST STEP	RESULT	ACTION TO TAKE
DN93 CONTINUOUS MEMORY CODE 31/327 AND/OR 35/337: CHECK EEC-IV VEHICLE HARNESS		
<p>Continuous Memory Code 31/327 indicated an open in the EVP or VREF circuit, or a short to SIG RTN with the engine at stabilized operating temperature and at idle.</p> <p style="text-align: center;">CODE 31/327</p>  <p style="text-align: center;">PROCESSOR HARNESS EVP SENSOR</p> <p>Continuous Memory Code 35/337 indicated a short to VREF and/or VPWR, or an open in SIG RTN with the engine at stabilized operating temperature and at idle.</p> <p style="text-align: center;">CODE 35/337</p>  <p style="text-align: center;">PROCESSOR HARNESS EVP SENSOR</p> <ul style="list-style-type: none"> • Enter Key On Engine Off Continuous Monitor mode. (Refer to TESTING PROCEDURES/ QUICK TEST AND DIAGNOSTIC AIDS/DETAILED QUICK TEST PROCEDURES/ CONTINUOUS MEMORY CODES for procedures). • Observe VOM or STAR LED for a fault indication while performing the following: <ul style="list-style-type: none"> — Refer to illustration above by code for possible circuit faults. — Grasp the harness close to the sensor connector. Wiggle, shake or bend a small section of the EEC-IV system vehicle harness while working your way to the dash panel. Also wiggle, shake or bend the EEC-IV vehicle harness from the dash panel to the processor. • Is a fault indicated? 	<p>Yes</p> <p>No</p>	<p>ISOLATE fault and SERVICE as necessary. REFER to appropriate figure. CLEAR Continuous Memory.</p> <p>(Refer to TESTING PROCEDURES/QUICK TEST AND DIAGNOSTIC AIDS/DETAILED QUICK TEST PROCEDURES/ CONTINUOUS MEMORY CODES for procedures.)</p> <p>RERUN Quick Test. (Refer to TESTING PROCEDURES/QUICK TEST AND DIAGNOSTIC AIDS/DETAILED QUICK TEST PROCEDURES/ KEY ON ENGINE OFF SELF TEST for quick test procedures).</p> <p>GO to DN94 .</p>

EEC-IV Pinpoint Test

TEST STEP		RESULT	ACTION TO TAKE
DN94	CHECK PROCESSOR AND HARNESS CONNECTORS	Yes	For further diagnosis using the EEC-IV Monitor box, Go to TESTING PROCEDURES/INTERMITTENT FAULT DIAGNOSIS. If the fault is not identified by the EEC-IV Monitor Box Diagnosis, then CLEAR Continuous Memory (Refer to TESTING PROCEDURES/QUICK TEST AND DIAGNOSTIC AIDS/ DETAILED QUICK TEST PROCEDURES /CONTINUOUS MEMORY CODES.) Go to EMISSION CONTROLS for EGR valve diagnosis.
	<ul style="list-style-type: none"> • Key off. • Disconnect processor 60 pin connector. Inspect for damaged or pushed out pins, corrosion, loose wires, etc. on both the processor and harness connectors. • Are connectors and terminals OK? 	No	SERVICE as necessary. CLEAR Continuous Memory (Refer to TESTING PROCEDURES/QUICK TEST AND DIAGNOSTIC AIDS/ DETAILED QUICK TEST PROCEDURES/ CONTINUOUS MEMORY CODES.) RERUN Quick Test. (Refer to TESTING PROCEDURES/QUICK TEST AND DIAGNOSTIC AIDS/ DETAILED QUICK TEST PROCEDURES/ KEY ON ENGINE OFF SELF TEST for quick test procedures).
DN95	CONTINUOUS MEMORY CODE 33/332: LEAK TEST	Yes	REMOVE vacuum pump. RECONNECT EGR valve. GO to DN96 .
	<p>Continuous Memory Code 33/332 indicated that the EGR valve did not open with the engine at stabilized temperature and with an EVR solenoid duty cycle present.</p> <p>Possible causes are:</p> <ul style="list-style-type: none"> — Obstructed or cracked vacuum hose to EGR valve. — Open circuit. — Faulty EGR valve. • Key off. • Disconnect vacuum hose at EGR valve. • Connect a vacuum pump to EGR valve. • Apply 20 in-Hg (66 kPa) to EGR valve. • Does EGR valve open and maintain vacuum? 	No	REMOVE vacuum pump. RECONNECT EGR valve. CLEAR Continuous Memory Code 33/334. (Refer to TESTING PROCEDURES /QUICK TEST AND DIAGNOSTIC AIDS/ DETAILED QUICK TEST PROCEDURES/CONTINUOUS MEMORY CODES.) GO to EMISSION CONTROLS for EGR valve diagnosis.

EEC-IV Pinpoint Test

TEST STEP		RESULT	ACTION TO TAKE
DN96	EVR SOLENOID CHECK		
<ul style="list-style-type: none"> • Use Key On Engine Off Continuous Monitor mode (Refer to TESTING PROCEDURES/QUICK TEST AND DIAGNOSTIC AIDS/DETAILED QUICK TEST PROCEDURES/CONTINUOUS MEMORY CODES). • Observe VOM or STAR LED for indication of a fault while performing the following: <ul style="list-style-type: none"> — Grasp the vehicle harness close to the EVR solenoid connector, wiggle, shake or bend a small section of the vehicle harness while working your way to the processor. • Inspect connectors, terminals for obvious damage or faults. • Are any faults detected? 		Yes	ISOLATE fault and SERVICE as necessary. CLEAR Continuous Memory. (Refer to TESTING PROCEDURES/QUICK TEST AND DIAGNOSTIC AIDS/DETAILED QUICK TEST PROCEDURES/CONTINUOUS MEMORY CODES.) RERUN Quick Test. (Refer to TESTING PROCEDURES/QUICK TEST AND DIAGNOSTIC AIDS/DETAILED QUICK TEST PROCEDURES/KEY ON ENGINE OFF SELF TEST for quick test procedures.)
		No	Unable to duplicate and/or identify fault at this time. For further diagnosis using the EEC-IV Monitor box, GO to TESTING PROCEDURES/INTERMITTENT FAULT DIAGNOSIS. All others, CLEAR Continuous Memory(Refer to TESTING PROCEDURES/QUICK TEST AND DIAGNOSTIC AIDS/DETAILED QUICK TEST PROCEDURES/CONTINUOUS MEMORY CODES) RERUN Quick Test. (Refer to TESTING PROCEDURES/QUICK TEST AND DIAGNOSTIC AIDS/DETAILED QUICK TEST PROCEDURES/KEY ON ENGINE OFF SELF TEST for quick test procedures.)
DN98	CONTINUOUS MEMORY CODE 34/334: CHECK EVP RESISTANCE WHILE APPLYING VACUUM TO EGR VALVE		
<p>Continuous Memory Code 34/334 indicated that the EGR valve was open with the engine at stabilized operating temperature and at idle.</p> <p>Possible causes are:</p> <ul style="list-style-type: none"> — Faulty EVR filter. — Faulty EVR solenoid. — Faulty EGR valve. <ul style="list-style-type: none"> • Key off. • Disconnect EVP sensor. • Disconnect vacuum hose at EGR valve. • Connect vacuum pump to EGR valve. • Measure resistance between EVP circuit and VREF circuit at the EVP sensor while increasing vacuum to 10 in-Hg (33 kPa). • Observe resistance as vacuum increases. • Does resistance gradually change from no more than 5,500 ohms to no less than 100 ohms as the vacuum increases? 		Yes	REMOVE vacuum pump. RECONNECT all components. CLEAR Continuous Memory Code 34/334 (Refer to TESTING PROCEDURES/QUICK TEST AND DIAGNOSTIC AIDS/DETAILED QUICK TEST PROCEDURES/CONTINUOUS MEMORY CODES.) GO to DN99.
		No	REMOVE vacuum pump. RECONNECT all components. CLEAR Continuous Memory Code 34/334. (Refer to TESTING PROCEDURES/QUICK TEST AND DIAGNOSTIC AIDS/DETAILED QUICK TEST PROCEDURES/CONTINUOUS MEMORY CODES.) GO to EMISSION CONTROLS for EGR valve diagnosis.

EEC-IV Pinpoint Test

TEST STEP	RESULT	ACTION TO TAKE
DN99 EVR CHECK	Yes	<p>CHECK EVR filter for obstructions. REPLACE as necessary. If OK, REPLACE EVR solenoid. RECONNECT all vacuum lines. CLEAR Continuous Memory . (Refer to TESTING PROCEDURES/ QUICK TEST AND DIAGNOSTIC AIDS/DETAILED QUICK TEST PROCEDURES/CONTINUOUS MEMORY CODES) RERUN Quick Test. (Refer to TESTING PROCEDURES/QUICK TEST AND DIAGNOSTIC AIDS/DETAILED QUICK TEST PROCEDURES/KEY ON ENGINE OFF SELF TEST for quick test procedures.)</p>
<ul style="list-style-type: none"> • Key off. • Disconnect vacuum hose from EGR valve and plug hose. • Rerun Engine Running Self-Test. (Refer to TESTING PROCEDURES/QUICK TEST AND DIAGNOSTIC AIDS/DETAILED QUICK TEST PROCEDURE /KEY ON ENGINE OFF SELF TEST and ENGINE RUNNING SELF TEST for test procedures). • Is Code 34 or 334 present? 	No	<p>Unable to duplicate and/or identify fault at this time. For further diagnosis using the EEC-IV Monitor box, Go to TESTING PROCEDURES/INTERMITTENT FAULT DIAGNOSIS.</p> <p>All others, CLEAR Continuous Memory (Refer to TESTING PROCEDURES/QUICK TEST AND DIAGNOSTIC AIDS/DETAILED QUICK TEST PROCEDURES/CONTINUOUS MEMORY CODES.) RERUN Quick Test. (Refer to TESTING PROCEDURES/QUICK TEST AND DIAGNOSTIC AIDS/DETAILED QUICK TEST PROCEDURES/KEY ON ENGINE OFF SELF TEST for quick test procedures.)</p>

EEC-IV Pinpoint Test

Note

You should enter this Pinpoint Test only when you have been directed here from Quick Test or from Pinpoint Test **TC**.

Remember

This Pinpoint Test is intended to diagnose only the following:

- VSS Harness Circuits
- Vehicle Speed Sensor (9E731)
- Processor Assembly (12A650)

Pinpoint Test Schematic

*TEST PIN 6 
TEST PIN 3 

VSS DIF (-) 
VSS DIF (+) 



VEHICLE
SPEED
SENSOR (VSS)
VEHICLE
HARNESS
CONNECTOR

*TEST PINS LOCATED ON BREAKOUT BOX.
ALL HARNESS CONNECTORS VIEWED INTO MATING SURFACE.

EEC-IV Pinpoint Test

Test Pin 3		VSS (+)	
Application		Wire Color	
2.3L Ranger 2.9L Ranger 3.0L Aerostar 3.0L EFI-MA Ranger 4.0L Explorer/Ranger 4.9L F-Series/Bronco 5.0L F-Series/Bronco 5.8L F-Series/Bronco 7.3L F-Series Diesel 7.5L F-Series		GY/BK	
All Others		DG/W	
Test Pin 6		VSS (-)	
Application		Wire Colors	
4.9L E-Series 5.0L E-Series 5.8L E-Series 7.3L E-Series Diesel 7.5L E-Series		O/Y	
All Others		PK/O	

EEC-IV Pinpoint Test

TEST STEP		RESULT	ACTION TO TAKE
DP1	CONTINUOUS MEMORY CODES 29/452: COMPLETE VSS DRIVE CYCLE: VERIFY CODE OR DRIVE COMPLAINT		
<p>Continuous Memory Code 29 or 452 indicates that sometime during the last 40 or 80 warm-up cycles, the processor detected an error in the vehicle speed sensor output signal.</p> <p>Possible causes:</p> <ul style="list-style-type: none"> — Faulty vehicle speed sensor. — Faulty harness circuits. — Faulty processor. <ul style="list-style-type: none"> • Perform Vehicle Speed Sensor Drive Cycle outlined below, all vehicles except the 3.0L EFI Aerostar. <p>FOR 3.0L EFI Aerostar:</p> <ul style="list-style-type: none"> — Obey all local traffic laws and road test the vehicle to verify the drive complaint. <ul style="list-style-type: none"> • VEHICLE SPEED SENSOR (VSS) DRIVE CYCLE: Record and clear continuous memory codes. — Warm engine to operating temperature. <p>AUTOMATIC TRANSMISSIONS:</p> <ul style="list-style-type: none"> — Place gear selector in LOW. — Obey all local traffic laws. Accelerate heavily to 35 MPH. — Coast down to an idle and stop the vehicle. — Shut the engine off. — After the drive cycle is completed, run Key On Engine Off Self-Test and record the continuous memory service codes displayed. <p>MANUAL TRANSMISSIONS:</p> <ul style="list-style-type: none"> — From first gear, shift to second. — Obey all local traffic laws. Accelerate moderately to 40 MPH. — Coast down to an idle and stop the vehicle. — Shut the engine off. — After the drive cycle is completed, run Key On Engine Off Self-Test and record the continuous memory service codes displayed. <ul style="list-style-type: none"> • For 3.0L EFI Aerostar, can drive complaint be verified? • All others, did Continuous Memory Code 29 or 452 repeat? 		<p>Yes</p> <p>No</p>	<p>GO to DP2 .</p> <p>Unable to duplicate and/or identify fault at this time. For further diagnosis using the EEC-IV Monitor box, Go to TESTING PROCEDURE INTERMITTENT FAULT DIAGNOSIS.</p> <p>All others, CLEAR Continuous Memory (Refer to TESTING PROCEDURES/QUICK TEST AND DIAGNOSTIC AIDS/DETAILED QUICK TEST PROCEDURES/CONTINUOUS MEMORY CODES).</p>

EEC-IV Pinpoint Test

TEST STEP		RESULT	ACTION TO TAKE
DP2	CHECK CONTINUITY OF VEHICLE SPEED SENSOR HARNESS CIRCUITS		
<ul style="list-style-type: none"> • Key off. • Disconnect processor 60 pin connector. Inspect for damaged or pushed out pins, corrosion, loose wires, etc. Service as necessary. • Install breakout box, processor disconnected. • Disconnect vehicle speed sensor. • Measure resistance between Test Pin 3 at the breakout box and VSSDIF (+) circuit at the vehicle speed sensor vehicle harness connector. • Measure resistance between Test Pin 6 at the breakout box and VSSDIF (-) circuit at the vehicle speed sensor vehicle harness connector. • Is each resistance less than 5 ohms? 		<p>Yes</p> <p>No</p>	<p>GO to DP3 .</p> <p>SERVICE open circuit. REMOVE breakout box. RECONNECT all components. REPEAT Test Step DP1 to verify elimination of code or drive complaint.</p>
DP3	CHECK VEHICLE SPEED SENSOR SIGNAL HARNESS CIRCUITS FOR SHORTS TO POWER OR GROUND		
<ul style="list-style-type: none"> • Key off. • Vehicle speed sensor disconnected. • Breakout box installed, processor disconnected. • Measure resistance between Test Pin 3 and Test Pins 6, 37 and 40 at the breakout box. • Is each resistance greater than 500 ohms? 		<p>Yes</p> <p>No</p>	<p>RECONNECT the processor. GO to DP4 .</p> <p>SERVICE short circuit. REMOVE breakout box. RECONNECT all components. REPEAT Test Step DP1 to verify elimination of the code or the drive complaint.</p>

EEC-IV Pinpoint Test

TEST STEP		RESULT	ACTION TO TAKE
DP4	CHECK VEHICLE SPEED SENSOR RESISTANCE		
<ul style="list-style-type: none"> • Key off. • Vehicle speed sensor disconnected. • Measure the resistance of the vehicle speed sensor. • Is resistance between 190 and 250 ohms? 		Yes	REMOVE breakout box. REPLACE processor. RECONNECT the vehicle speed sensor. REPEAT Test Step DP1 to verify elimination of code or drive complaint.
		No	REPLACE the vehicle speed sensor. REMOVE breakout box. REPEAT Test Step DP1 to verify the elimination of the code or drive complaint.
DP5	CHECK FOR SHORTED 4EAT MODULE		
<ul style="list-style-type: none"> • Key off. • Breakout box installed, processor disconnected. • VSS disconnected. • Reconnect both 4EAT module vehicle harness connectors. • Measure resistance between Test Pin 3 and Test Pins 6, 37 and 40 at the breakout box. • Is each resistance greater than 500 ohms? 		Yes	RECONNECT processor. GO to DP4
		No	Go to TRANSMISSIONS, CLUTCHES, DIFFERENTIALS, AXLES, AND DRIVE SHAFTS for transmission diagnosis.

EEC-IV Pinpoint Test

Note

You should enter this Pinpoint Test only when you have been directed here from Quick Test.

Remember

This Pinpoint Test is intended to diagnose only the following:

- BOO circuit
- Processor assembly (12A650)

Pinpoint Test Schematic

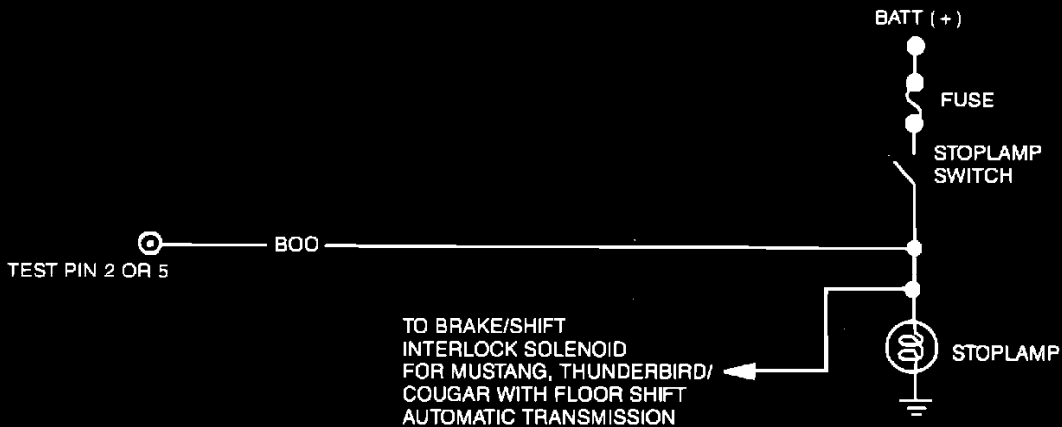

* TEST PINS LOCATED ON BREAKOUT BOX.
ALL HARNESS CONNECTORS VIEWED INTO MATING SURFACES.

BOO	
Application	Test Pin Number
All	2

BOO	
Application	Wire Color
Aerostar (4.0L)	R/LG
All Others	LG

EEC-IV Pinpoint Test

TEST STEP		RESULT	ACTION TO TAKE
FD1	SERVICE CODE 74/536 VERIFY BRAKE WAS PRESSED		
	Service Code 74/536 indicates that when the brake pedal was depressed and released during the Engine Running Self-Test, the BOO signal did not cycle high and low. Possible causes are: <ul style="list-style-type: none"> — Brake pedal not depressed and released during the Engine Running Self-Test. — Brake pedal depressed during entire Engine Running Self-Test. — Open BOO/stoplamp circuit. — Short to GROUND or POWER. — Faulty brake switch. — Faulty processor. <ul style="list-style-type: none"> • Did you press brake during the Engine Running Self-Test? <p>NOTE: On some vehicles it is necessary to depress and release the brake after the dynamic response code 1(0) but before the brief WOT.</p>	Yes No	GO to FD2 . RERUN Engine Running Self-Test. (Refer to TESTING PROCEDURES/QUICK TEST AND DIAGNOSTIC AIDS/DETAILED QUICK TEST PROCEDURES/KEY ON ENGINE RUNNING SELF TEST for test procedures PRESS brake once during test.
FD2	CHECK OPERATION OF STOPLAMPS		
	<ul style="list-style-type: none"> • Key on. • Check stoplamp operation. 	Stoplamps operate normally Stoplamps never on Stoplamps always on	GO to FD3 . GO to FD4 . GO to FD5 .

EEC-IV Pinpoint Test

TEST STEP		RESULT	ACTION TO TAKE
FD3	CHECK FOR BOO CIRCUIT CYCLING	Yes	REPLACE processor. REMOVE breakout box. RERUN Quick Test. (Refer to TESTING PROCEDURES/QUICK TEST AND DIAGNOSTIC AIDS/DETAILED QUICK TEST PROCEDURES/KEY ON ENGINE OFF SELF TEST for quick test procedures.)
	<ul style="list-style-type: none"> • Key off. • Disconnect processor 60 pin connector. Inspect for damaged or pushed out pins, corrosion, loose wires, etc. Service as necessary. • Install breakout box, leave processor disconnected. • DVOM on 20 volt scale. • Measure voltage between BOO Test Pin (Refer to chart on FD cover page) and Test Pin 40 at the breakout box while depressing and releasing brake. • Does the voltage cycle? 	No	SERVICE open in BOO circuit between processor and BOO connection to stoplamp circuit. RERUN Quick Test. Refer to TESTING PROCEDURES/QUICK TEST AND DIAGNOSTIC AIDS/DETAILED QUICK TEST PROCEDURES/KEY ON ENGINE OFF SELF TEST for quick test procedures.)
FD4	CHECK FOR POWER TO BRAKE SWITCH	Yes	VERIFY operation of brake switch. If OK, SERVICE open circuit between brake switch and stoplamp ground. RECONNECT brake switch connector. RERUN Quick Test. (Refer to TESTING PROCEDURES/QUICK TEST AND DIAGNOSTIC AIDS/DETAILED QUICK TEST PROCEDURES/KEY ON ENGINE OFF SELF TEST for quick test procedures.)
	<p>NOTE: Verify integrity of related fuses in fuse panel and condition of stoplamp bulbs.</p> <ul style="list-style-type: none"> • Key off. • Disconnect brake switch (located on brake pedal). • Measure voltage between BATT (+) input to brake switch and chassis ground. • Is voltage greater than 10 volts? 	No	SERVICE open BATT (+) circuit to brake switch. RECONNECT brake switch connector. RERUN Quick Test. (Refer to TESTING PROCEDURES/QUICK TEST AND DIAGNOSTIC AIDS/DETAILED QUICK TEST PROCEDURES/KEY ON ENGINE OFF SELF TEST for quick test procedures.)
FD5	VERIFY BRAKE SWITCH IS NOT ALWAYS CLOSED	Yes	GO to FD6
	<ul style="list-style-type: none"> • Key off. • Disconnect brake switch (located on brake pedal). • Key on, engine off. • Are stoplamps still on? 	No	VERIFY proper installation brake switch. If OK, REPLACE brake switch. RECONNECT harness connector. RERUN Quick Test. (Refer to TESTING PROCEDURES/QUICK TEST AND DIAGNOSTIC AIDS/DETAILED QUICK TEST PROCEDURES/KEY ON ENGINE OFF SELF TEST for quick test procedures.)

EEC-IV Pinpoint Test

TEST STEP		RESULT	ACTION TO TAKE
FD6	CHECK FOR SHORT TO POWER IN PROCESSOR		
<ul style="list-style-type: none"> • Key off. • Brake switch disconnected. • Disconnect processor. • Key on, engine off. • Are stoplamps still on? 		Yes	<p>SERVICE short to power in BOO/Stoplamp circuit. RECONNECT all components. RERUN Quick Test.</p> <p>(Refer to TESTING PROCEDURES/QUICK TEST AND DIAGNOSTIC AIDS/DETAILED QUICK TEST PROCEDURES/KEY ON ENGINE OFF SELF TEST for quick test procedures)</p>
		No	<p>REPLACE processor. RECONNECT brake switch. RERUN Quick Test.</p> <p>(Refer to TESTING PROCEDURES/QUICK TEST AND DIAGNOSTIC AIDS/DETAILED QUICK TEST PROCEDURES/KEY ON ENGINE OFF SELF TEST for quick test procedures)</p>
FD7	CHECK FOR SHORT TO POWER IN BRAKE/SHIFT INTERLOCK SOLENOID		
<ul style="list-style-type: none"> • Key off. • Processor disconnected. • Brake switch disconnected. • Disconnect brake/shift interlock solenoid. • Key on. • Are stoplamps still on? 		Yes	<p>SERVICE short to power in BOO/Stoplamp circuit. RECONNECT processor, brake switch and brake/shift interlock solenoid. RERUN Quick Test.</p> <p>(Refer to TESTING PROCEDURES/QUICK TEST AND DIAGNOSTIC AIDS/DETAILED QUICK TEST PROCEDURES/KEY ON ENGINE OFF SELF TEST for quick test procedures)</p>
		No	<p>REPLACE brake/shift interlock solenoid. RECONNECT processor and brak switch. RERUN Quick Test.</p> <p>(Refer to TESTING PROCEDURES/QUICK TEST AND DIAGNOSTIC AIDS/DETAILED QUICK TEST PROCEDURES/KEY ON ENGINE OFF SELF TEST for quick test procedures)</p>

EEC-IV Pinpoint Test

TEST STEP		RESULT	ACTION TO TAKE
FD10	SERVICE CODE 75/531: CHECK OPERATION OF BRAKE LAMPS		
<p>Service Code 75/531 indicates that while the brake pedal was released during the Engine Running Self-Test, the BOO signal was high.</p> <p>Possible causes are:</p> <ul style="list-style-type: none"> — Brake pedal depressed during entire Engine Running Self-Test. — Open BOO/stoplamp circuit (between processor and stoplamp ground). — Short to POWER. — Faulty brake switch. — Faulty processor. <ul style="list-style-type: none"> • Key on. • Check stoplamp operation. 		<p>Stoplamps operate normally</p> <p>▶</p> <p>GO to FD11 .</p>	
		<p>Stoplamps always on</p> <p>▶</p> <p>GO to FD5 .</p>	
		<p>Stoplamps never on</p> <p>▶</p> <p>VERIFY condition of stoplamp bulbs. If OK, SERVICE open circuit between BOO connection and stoplamp ground. RERUN Quick Test.</p> <p>(Refer to TESTING PROCEDURES/QUICK TEST AND DIAGNOSTIC AIDS/DETAILED QUICK TEST PROCEDURES/KEY ON ENGINE OFF SELF TEST for Quick Test procedures)</p>	
FD11	CHECK BOO CIRCUIT CONTINUITY		
<ul style="list-style-type: none"> • Key off. • Disconnect processor 60 pin connector. Inspect for damaged or pushed out pins, corrosion, loose wires, etc. Service as necessary. • Install breakout box, leave processor disconnected. • Disconnect brake switch (located on brake pedal). • Measure resistance between Test Pin 2 at the breakout box and circuit to stoplamps pin at the brake switch vehicle harness connector. • Is resistance less than 5.0 ohms? 		<p>Yes</p> <p>▶</p> <p>REPLACE processor. RECONNECT brake switch. REMOVE breakout box. RERUN Quick Test.</p> <p>(Refer to TESTING PROCEDURES/QUICK TEST AND DIAGNOSTIC AIDS/DETAILED QUICK TEST PROCEDURES/KEY ON ENGINE OFF SELF TEST for Quick Test procedures.)</p>	
		<p>No</p> <p>▶</p> <p>SERVICE open BOO circuit between processor and BOO connection to stoplamp circuit. REMOVE breakout box. RECONNECT processor and brake switch. RERUN Quick Test.</p> <p>(Refer to TESTING PROCEDURES/QUICK TEST AND DIAGNOSTIC AIDS/DETAILED QUICK TEST PROCEDURES/KEY ON ENGINE OFF SELF TEST for Quick Test procedures.)</p>	

EEC-IV Pinpoint Test

TEST STEP		RESULT	ACTION TO TAKE
FD90	CONTINUOUS MEMORY CODE 536: CHECK FOR PROPER STOPLAMP SWITCH INSTALLATION		
<p>Continuous Memory Code 536 indicates a BOO circuit failure. If the BOO input does not cycle after a predetermined number of transitions from 0 mph to a specific speed, the BOO input is assumed to be damaged and Continuous Memory Code 536 is set.</p> <p>Possible causes are:</p> <ul style="list-style-type: none"> — Stoplamp switch improperly installed. — Open stoplamp/BOO circuit. — Stoplamp/BOO circuit shorted to power. — Damaged stoplamp switch. — Damaged stoplamp ground connection. <ul style="list-style-type: none"> • Check stoplamp switch for proper installation (alignment with pedal), corrosion, frayed wires, etc. • Is stoplamp switch in good condition and properly installed? 		<p>Yes</p> <p>No.</p>	<p>▶ GO to FD91 .</p> <p>▶ SERVICE as necessary. CLEAR Continuous Memory. (Refer to TESTING PROCEDURES/QUICK TEST AND DIAGNOSTIC AIDS/DETAILED QUICK TEST PROCEDURES/CONTINUOUS MEMORY CODES) RERUN Quick Test. (Refer to TESTING PROCEDURES/QUICK TEST AND DIAGNOSTIC AIDS/DETAILED QUICK TEST PROCEDURES/KEY ON ENGINE OFF SELF TEST for quick test procedures.)</p>
FD91	CHECK STOPLAMP GROUND		
<ul style="list-style-type: none"> • Check stoplamp ground connection for corrosion or other damage. • Check stoplamp connector and wires for corrosion or other damage. • Are stoplamp wires, connector, and ground connection OK? 		<p>Yes</p> <p>No</p>	<p>▶ GO to FD92 .</p> <p>▶ SERVICE as necessary. CLEAR Continuous Memory. (Refer to TESTING PROCEDURES/QUICK TEST AND DIAGNOSTIC AIDS/DETAILED QUICK TEST PROCEDURES/CONTINUOUS MEMORY CODES) RERUN Quick Test. (Refer to TESTING PROCEDURES/QUICK TEST AND DIAGNOSTIC AIDS/DETAILED QUICK TEST PROCEDURES/KEY ON ENGINE OFF SELF TEST for quick test procedures.)</p>
FD92	CHECK STOPLAMP/BOO CIRCUITS FOR SHORT TO POWER		
<ul style="list-style-type: none"> • Key on, engine off. • Brake pedal NOT depressed. • Wiggle stoplamp/BOO circuit wires and connectors while observing stoplamps. • Do the stoplamps flash on while wiggling? 		<p>Yes</p> <p>No</p>	<p>▶ ISOLATE short to power and SERVICE as necessary. CLEAR Continuous Memory . (Refer to TESTING PROCEDURES/QUICK TEST AND DIAGNOSTIC AIDS/DETAILED QUICK TEST PROCEDURES/CONTINUOUS MEMORY CODES) RERUN Quick Test. (Refer to TESTING PROCEDURES/QUICK TEST AND DIAGNOSTIC AIDS/DETAILED QUICK TEST PROCEDURES/KEY ON ENGINE OFF SELF TEST for quick test procedures.)</p> <p>▶ GO to FD93 .</p>

EEC-IV Pinpoint Test

TEST STEP		RESULT	ACTION TO TAKE
FD93	CHECK STOPLAMP CIRCUIT CONTINUITY	Yes	ISOLATE open in stoplamp circuit and SERVICE as necessary. CLEAR Continuous Memory (Refer to TESTING PROCEDURES/QUICK TEST AND DIAGNOSTIC AIDS/DETAILED QUICK TEST PROCEDURES/CONTINUOUS MEMORY CODES). RERUN Quick Test. (Refer to TESTING PROCEDURES/QUICK TEST AND DIAGNOSTIC AIDS/DETAILED QUICK TEST PROCEDURES/KEY ON ENGINE OFF SELF TEST for quick test procedures)
	<ul style="list-style-type: none"> • Key off. • Depress brake pedal and hold. • Wiggle stoplamp circuit wires and connectors while observing stoplamps. • Lightly tap stoplamp switch (simulate road shock) while observing stoplamps. • Do the stoplamps ever go off? 	No	GO to FD94 .
FD94	CHECK BOO CIRCUIT CONTINUITY	Yes	ISOLATE open in BOO circuit and SERVICE as necessary. REMOVE breakout box. RECONNECT processor. RERUN Quick Test. (Refer to TESTING PROCEDURES/QUICK TEST AND DIAGNOSTIC AIDS/DETAILED QUICK TEST PROCEDURES/KEY ON ENGINE OFF SELF TEST for quick test procedures)
	<ul style="list-style-type: none"> • Key off. • Release brake pedal. • Disconnect processor 60 pin connector. Inspect for damaged or pushed out pins, corrosion, loose wires, etc. Service as necessary. • Install breakout box, leave processor disconnected. • Connect DVOM between BOO Test Pin (refer to schematic) at the breakout box and stoplamp circuit at the stoplamp switch. • DVOM on 200 ohm scale. • Wiggle BOO circuit wires and connectors while observing DVOM. • Is the resistance ever greater than 5 ohms while wiggling? 	No	For further diagnosis using the EEC-IV Monitor Box, GO to TESTING PROCEDURES/INTERMITTENT FAULT DIAGNOSIS If an EEC-IV Monitor Box is not available, GO to FD99 .

EEC-IV Pinpoint Test

FD99 ROAD TEST

The purpose of the road test is to identify an area of concern by monitoring certain controlled parameters while trying to re-create a driveability or MIL light symptom.

NOTE

A basic working knowledge of the EEC-IV system is critical to effectively analyze road test data.

WARNING

THIS ROAD TEST IS A SUGGESTED BUT OPTIONAL PROCEDURE. ALL APPLICABLE SAFETY PROCEDURES AND TRAFFIC LAWS MUST BE FOLLOWED. IN ORDER FOR A ROAD TEST TO BE PERFORMED IT IS REQUIRED THAT ANOTHER PERSON ACCOMPANY THE DRIVER. THE ACCOMPANYING PERSON CAN MAKE MEASUREMENTS, OBSERVE CHANGES AND RECORD NOTES. IF FOR SOME REASON THIS TEST IS NOT PERFORMED, RETURN TO DIAGNOSTIC ROUTINES FOR OTHER POSSIBLE CAUSES.

PREPARE VEHICLE FOR A ROAD TEST

- Breakout box installed, processor connected.
- Install fuel pressure gauge and MAP/BP tester (optional).
- Other materials needed; DVOM, pencil, paper, appropriate schematic/pin usage sheet (from SCHEMATIC DIAGRAMS/ELECTRICAL AND ELECTRONIC DIAGRAMS).

PRELIMINARY POWER/GROUND CHECKS

- With the key ON and a DVOM referenced to the battery negative post, check the following signals for correct values.
POWERS: KAPWR >10.5V (pin 1); VPWR >10.5V (pins 37/57); VREF 5±1V (pin 26)
GROUNDS (all = 0±.5V): PWR GND (pins 40/60); SIG RTN (pin 46); IGN GND (pin 16)
OPTIONAL GROUNDS: HEGO GND (pin 49); CSE GND (pin 20); MAF RTN (pin 9 or 15)

OBTAINING OTHER NEEDED INFORMATION AND MATERIALS BEFORE THE ROAD TEST

- Refer to the Symptom Charts TESTING PROCEDURES/INTERMITTENT FAULT DIAGNOSIS, looking at the chart(s) that closest resembles the vehicle's driveability or MIL light symptom. Before the road test perform the Visual/Mechanical Checks that are listed. Next, list the EEC-IV sensors and actuators in the order given. These circuits, along with the BOO signal, are the main circuits that will be monitored.

EEC-IV Pinpoint Test

FD99 ROAD TEST (CONTINUED)

- Refer to the proper Diagnostic Reference Value Sheet in TESTING PROCEDURES/INTERMITTENT FAULT DIAGNOSIS/DIAGNOSTIC REFERENCE VALUES. Although these charts were designed for use with the EEC-IV Monitor Box, most of the values can be read using the breakout box and a DVOM (with the DVOM referenced to ground all values in DCV units can be used; other values may also be helpful, ex. MAP Hz using the MAP/BP tester). Also refer to TESTING PROCEDURES/INTERMITTENT FAULT DIAGNOSIS/ GRAPHS AND CHARTS.
- The use of test lamps may also aid diagnosis. For example, a test lamp could be connected at the stop lamp switch between BATT (+) and ground, with another connected between the "power to bulbs" pin and ground. The BATT (+) lamp should always stay on, with the "power to bulbs" lamp on only when the brake is depressed. Also, with a DVOM connected between the BOO Test Pin and Test Pin 40 at the breakout box, if 6-7 volts is shown with the brake pedal released, this could indicate an open circuit between the processor and stop lamp ground (the processor supplies 6-7 volts on the BOO circuit, but this voltage is not "strong" enough to light the stop lamps or most test lamps).

ROAD TEST

- Drive the vehicle to create the conditions so that the symptom will occur. If the Driveability Worksheet from TECHNICAL-MANAGEMENT SUPPORT has been completed, this information may help when trying to re-create the symptom.
- When the symptom occurs, the accompanying passenger should observe changes in listed EEC-IV signals. Information about the symptom, operating condition value of the EEC-IV signal or other notes should be recorded onto paper.
- If you are unable to duplicate the symptom, it may still be helpful to verify that the EEC-IV values are in the expected range.

ANALYZING THE DATA

- Once the road test is completed, the results need to be analyzed to locate and repair the exact fault which cause the symptom.
- If no problem is identified, return to TESTING PROCEDURES/DIAGNOSTIC ROUTINES for other possible causes of the symptom.

EEC-IV Pinpoint Test

Note

You should enter this Pinpoint Test only when you have been directed here from Quick Test.

Remember

To prevent the replacement of good components, be aware that the following non-EEC areas may be at fault:

- Idle speed/throttle stop adjustment
- Binding throttle shaft/linkage or speed control linkage

This Pinpoint Test is intended to diagnose only the following:

- Power steering pressure switch (-3N824-)
- Harness circuits: PSPS and SIG RTN
- Processor assembly (-12A650-)

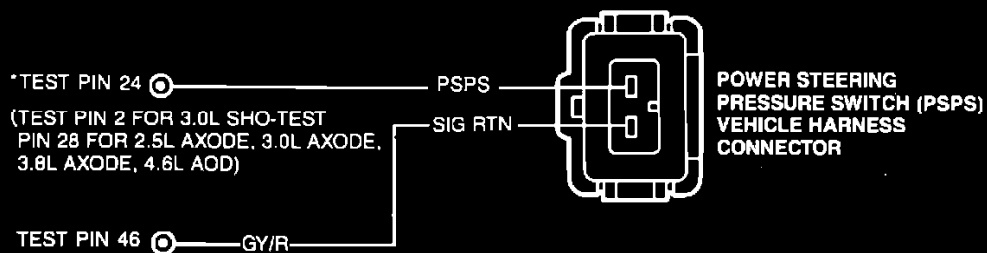
Pinpoint Test Schematic

*TEST PINS LOCATED ON BREAKOUT BOX.
ALL HARNESS CONNECTORS VIEWED INTO MATING SURFACE.

Test Pin 2, 24 or 28	PSPS
Application	Wire Color
All	Y/LG

EEC-IV Pinpoint Test

TEST STEP		RESULT	ACTION TO TAKE
FF1	SERVICE CODE 52/519: ATTEMPT TO ELIMINATE CODE 52/519		
<p>NOTE: Some vehicles are equipped with a Power Steering Pressure Switch software strategy, but do not have Power Steering hardware released for the engine/vehicle application. When Service Code 52/519 is received in Key On Engine Off, check to see if the vehicle is equipped with Power Steering. If not, disregard servicing the Code 52/519. Return to Quick Test Section to service other codes.</p> <p>Service Code 52/519 indicates that the Power Steering Pressure Switch (PSPS) circuit is open.</p> <p>Possible causes are:</p> <ul style="list-style-type: none"> — Faulty PSPS switch. — Open harness. — Faulty processor. • Key off. • Disconnect PSPS. • Jumper PSPS circuit to SIG RTN circuit at the PSPS vehicle harness connector. • Rerun Key On or Engine Off Self-Test. • Is Code 52 or 519 still present? 		<p>Yes</p> <p>No</p>	<p>GO to FF2 .</p> <p>REPLACE PSPS. RERUN Quick Test. (Refer to TESTING PROCEDURES/QUICK TEST AND DIAGNOSTIC AIDS/DETAILED QUICK TEST PROCEDURES/KEY ON ENGINE OFF SELF TEST for quick test procedures)</p>
FF2	CHECK CONTINUITY OF PSPS CIRCUITS		
<ul style="list-style-type: none"> • Key off. • PSPS disconnected. • Disconnect processor 60 pin connector. Inspect for damaged or pushed out pins, corrosion, loose wires, etc. Service as necessary. • Install breakout box, leave processor disconnected. • Measure resistance between Test Pin 46 at the breakout box and SIG RTN circuit at the PSPS vehicle harness connector. • Measure resistance between Test Pin 24 at the breakout box and PSPS circuit at the PSPS vehicle harness connector. • Is each resistance less than 5 ohms? 		<p>Yes</p> <p>No</p>	<p>REPLACE processor. REMOVE breakout box. RECONNECT all components. RERUN Quick Test. (Refer to TESTING PROCEDURES/QUICK TEST AND DIAGNOSTIC AIDS/DETAILED QUICK TEST PROCEDURES/KEY ON ENGINE OFF SELF TEST for quick test procedures)</p> <p>SERVICE open circuit. REMOVE breakout box. RECONNECT all components. RERUN Quick Test. (Refer to TESTING PROCEDURES/QUICK TEST AND DIAGNOSTIC AIDS/DETAILED QUICK TEST PROCEDURES/KEY ON ENGINE OFF SELF TEST for quick test procedures)</p>

EEC-IV Pinpoint Test

TEST STEP		RESULT	ACTION TO TAKE
FF3	CHECK PSPS OPERATION		
<ul style="list-style-type: none"> • Key off. • Install tachometer. • Start engine, allow to idle in NEUTRAL/PARK. • Disconnect PSPS. • Does rpm increase? 		Yes	REPLACE PSPS. RE-EVALUATE symptom.
		No	GO to FF4 .
FF4	CHECK PSPS CIRCUITS FOR SHORTS		
<ul style="list-style-type: none"> • Key off. • PSPS disconnected. • Disconnect processor 60 pin connector. Inspect for damaged or pushed out pins, corrosion, loose wires, etc. Service as necessary. • Install breakout box, leave processor disconnected. • DVOM on 200,000 ohm scale. • Measure resistance between Test Pin 24 (Test Pin 2 for 3.0L SHO) and Test Pin 46 at the breakout box. 		Yes	SERVICE short in harness. REMOVE breakout box. RECONNECT all components. RE-EVALUATE symptom.
<ul style="list-style-type: none"> • Is resistance less than 10,000 ohms? 		No	REPLACE processor. REMOVE breakout box. RECONNECT all components. RE-EVALUATE symptom.

EEC-IV Pinpoint Test

TEST STEP		RESULT	ACTION TO TAKE
FF5	ENGINE RUNNING SERVICE CODE 52/521		
<p>NOTE: Some vehicles are equipped with a Power Steering Pressure Switch software strategy, but do not have Power Steering hardware released for the engine/vehicle application. When Service Code 52/521 is received in Key On Engine Running, check to see if the vehicle is equipped with Power Steering. If not, disregard servicing the Code 52/521. Return to Quick Test Section to service other codes.</p> <p>Engine Running Service Code 52/521 indicates that the Power Steering Pressure Switch (PSPS) did not change states due to the switch staying either open or closed.</p> <p>Possible causes are:</p> <ul style="list-style-type: none"> — Faulty PSPS switch. — Open or grounded harness circuit. — Faulty processor. <p>• Did you turn the steering wheel at least one-half turn within 1 to 2 seconds after engine ID code?</p> <p>NOTE: Make sure the front wheels are centered (no load condition).</p>		<p>Yes</p> <p>No</p>	<p>GO to FF6 .</p> <p>RERUN Quick Test. (Refer to TESTING PROCEDURES/QUICK TEST AND DIAGNOSTIC AIDS/DETAILED QUICK TEST PROCEDURES/KEY ON ENGINE OFF SELF TEST for Quick Test procedures.)</p>
FF6	DETERMINE WHETHER THE PROCESSOR CAN IDENTIFY AN OPEN CIRCUIT		
<ul style="list-style-type: none"> • Key off, wait 10 seconds. • PSPS disconnected. • Run Key On Engine Off Self-Test. (Refer to TESTING PROCEDURES/QUICK TEST AND DIAGNOSTIC AIDS/DETAILED QUICK TEST PROCEDURES/KEY ON ENGINE OFF SELF TEST for quick test procedures) • Is Code 52 or 519 present? 		<p>Yes</p> <p>No</p>	<p>GO to FF8 .</p> <p>GO to FF7 .</p>
FF7	CHECK PSPS CIRCUITS FOR SHORTS		
<ul style="list-style-type: none"> • Key off. • PSPS disconnected. • Disconnect processor 60 pin connector. Inspect for damaged or pushed out pins, corrosion or loose wires, etc. Service as necessary. • Install breakout box, leave processor disconnected. • Measure resistance between Test Pin 46 and Test Pin 24 (Test Pin 2 for 3.0L SHO) at the breakout box. <p>• Is resistance 10,000 ohms or less?</p>		<p>Yes</p> <p>No</p>	<p>SERVICE short circuit. REMOVE breakout box. RECONNECT all components. RERUN Quick Test. (Refer to TESTING PROCEDURES/QUICK TEST AND DIAGNOSTIC AIDS/DETAILED QUICK TEST PROCEDURES/KEY ON ENGINE OFF SELF TEST for Quick Test procedures.)</p> <p>REPLACE processor. REMOVE breakout box. RECONNECT all components. RERUN Quick Test. (Refer to TESTING PROCEDURES/QUICK TEST AND DIAGNOSTIC AIDS/DETAILED QUICK TEST PROCEDURES/KEY ON ENGINE OFF SELF TEST for Quick Test procedures.)</p>

EEC-IV Pinpoint Test

TEST STEP		RESULT	ACTION TO TAKE
FF8	CHECK PSPS STATE WITH KEY ON ENGINE OFF VS. RUNNING		
	<ul style="list-style-type: none"> • Key off. • Disconnect processor 60 pin connector. Inspect for damaged or pushed out pins, corrosion, loose wires, etc. Service as necessary. • Install breakout box and connect processor to breakout box. • Reconnect PSPS. • Key on, engine off. • Measure resistance between Test Pin 24 (Test Pin 2 for 3.0L SHO) and Test Pin 46 at the breakout box. <p>• Start engine.</p> <p>• Does resistance remain less than 10 ohms between Key On Engine Off and Engine Running?</p>	<p>Yes</p> <p>No</p>	<p>▶ GO to FF8</p> <p>▶ GO to FF11 .</p>
FF9	CHECK PSPS STATE WITH ENGINE RUNNING NO LOAD VS. LOAD		
	<ul style="list-style-type: none"> • Engine idling. • Breakout box installed, processor connected. • PSPS connected. • Clutch is not depressed on 3.0L SHO-SEFI manual vehicles. • Measure the resistance between Test Pin 24 (Test Pin 2 for 3.0L SHO) and Test Pin 46 at the breakout box. <p>• Turn the steering wheel at least one-half turn then return.</p> <p>• Does resistance change from less than 10 ohms to infinity (indicating PSPS opening), then returning to 10 ohms or less when steering wheel is returned to center position?</p>	<p>Yes</p> <p>No</p>	<p>▶ PSPS system OK, REMOVE breakout box and RETURN to Quick Test to continue Diagnostics. (Refer to TESTING PROCEDURES/QUICK TEST AND DIAGNOSTIC AIDS/DETAILED QUICK TEST PROCEDURES/KEY ON ENGINE OFF SELF TEST for Quick Test procedures.)</p> <p>▶ GO to FF10 .</p>

EEC-IV Pinpoint Test

TEST STEP		RESULT	ACTION TO TAKE
FF10	CHECK FOR PSPS ALWAYS CLOSED VS. POWER STEERING HYDRAULIC PRESSURE WITH ENGINE RUNNING		
<ul style="list-style-type: none"> • At this point in the Diagnostics there are only two possible causes for the original Code 52/521 Engine Running: <ul style="list-style-type: none"> — PSPS (switch) that will not open. — Low available hydraulic pressure. • Key off. • Substitute original PSPS with a known good PSPS. • Run Engine Running Self-Test. (Turn steering wheel at least one-half turn after Engine ID code.) • Is Code 52 or 521 still present? 		Yes	Go to STEERING, SUSPENSIONS, CHASSIS, AND BODY COMPONENTS looking for low pressure.
		No	Original Code 52 or 521 Engine Running was a result of a bad PSPS (switch). REMOVE all equipment and CONTINUE, if necessary, with any other Diagnostics. (Refer to TESTING PROCEDURES/QUICK TEST AND DIAGNOSTIC AIDS/DETAILED QUICK TEST PROCEDURES/KEY ON ENGINE OFF SELF TEST for quick test procedures)
FF11	CHECK FOR PSPS ALWAYS OPEN VS. POWER STEERING HYDRAULIC PRESSURE WITH ENGINE RUNNING		
<ul style="list-style-type: none"> • At this point in the Diagnostics there are two possible causes for the original Code 52/521 Engine Running: <ul style="list-style-type: none"> — PSPS (switch) that always remains open during Engine Running. — Excessively high hydraulic pressure. • Key off. • Substitute original PSPS with a known good PSPS. • Run Engine Running Self Test. (Turn steering wheel at least one-half turn after Engine ID code.) • Is Code 52 or 521 still present? 		Yes	GO to STEERING, SUSPENSIONS, AND BODY COMPONENTS, looking for high pressure.
		No	Original Code 52/521 Engine Running was a result of a bad PSPS (switch). REMOVE all equipment and CONTINUE, if necessary, with any other Diagnostics. (Refer to TESTING PROCEDURES/QUICK TEST AND DIAGNOSTIC AIDS/DETAILED QUICK TEST PROCEDURES/KEY ON ENGINE OFF SELF TEST for quick test procedures)

EEC-IV Pinpoint Test

Note

You should enter this Pinpoint Test only when you have been directed here from Quick Test.

Remember

To prevent the replacement of good components, be aware that the following non-EEC areas may be at fault:

- Excessive blow-by
- PCV malfunction
- Vacuum leaks
- Fuel pressure
- Throttle sticking or linkage binding

This Pinpoint Test is intended to diagnose only the following:

- MAP/BP sensor (9F479)
- Throttle Position (TP) sensor (9B989)
- Mass Air Flow (MAF) sensor (12B579)
- Air Charge Temperature (ACT) sensor (12A697)
- Fuel Injectors

EEC-IV Pinpoint Test

TEST STEP		RESULT	ACTION TO TAKE
G1	THROTTLE POSITION SENSOR INTEGRITY	Yes	<p>VERIFY TP sensor is properly installed to the throttle body. If OK, REPLACE TP sensor. REMOVE breakout box. RECONNECT processor. RERUN Quick Test. (Refer to TESTING PROCEDURES/QUICK TEST AND DIAGNOSTIC AIDS/DETAILED QUICK TEST PROCEDURES/KEY ON ENGINE OFF SELF TEST for quick test procedures)</p>
	<p>Continuous Memory code 121 indicates TPS was inconsistent with MAF value.</p> <p>Continuous Memory code 124 indicates TPS value was higher than expected.</p> <p>Continuous Memory code 125 indicates TPS value was lower than expected.</p> <ul style="list-style-type: none"> • Key off. • Disconnect processor 60 pin connector. Inspect for damaged or pushed out pins corrosion, loose wires, etc. Service as necessary. • Install breakout box and connect processor to breakout box. • DVOM on 20 volt scale. • Connect DVOM from Test Pin 47 to Test Pin 46 at the breakout box. • Rotate throttle slowly to WOT, release throttle slowly to closed position. • Are there any sudden voltage variations. <p>NOTE: Refer to PINPOINT TEST DH, STEP DH1 for schematics and specific engine values.</p>	No	<p>For continuous code 121: Go to G6 .</p> <p>For all others: Go to G2 .</p>
G2	CHECK THROTTLE BODY	Yes	GO to G3 .
	<ul style="list-style-type: none"> • Check throttle linkage and/or speed control linkage for binding. • Inspect throttle body for contamination. • Check engine vacuum hoses. Refer to VECI decal. • Check for air leaks between ISC solenoid and MAF sensor. • Are all of the above checks OK? 	No	<p>SERVICE as necessary. REMOVE breakout box. RECONNECT processor. RERUN Quick Test. (Refer to TESTING PROCEDURES/QUICK TEST AND DIAGNOSTIC AIDS/DETAILED QUICK TEST PROCEDURES/KEY ON ENGINE OFF SELF TEST for Quick Test procedures.)</p>

EEC-IV Pinpoint Test

Pinpoint Test Schematic

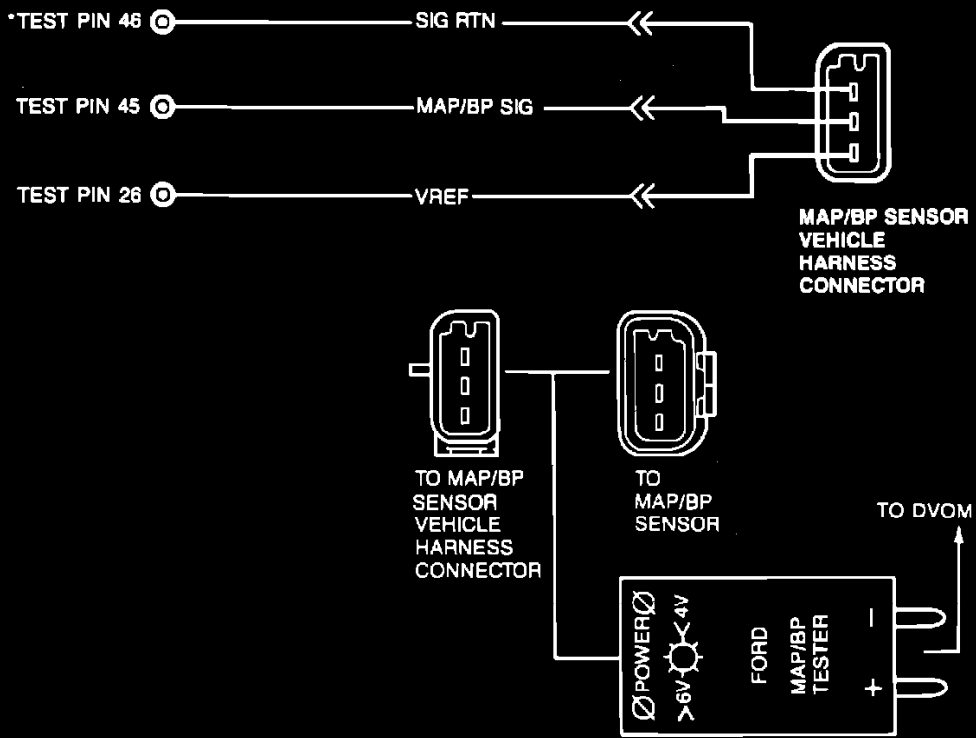

*TEST PINS LOCATED ON BREAKOUT BOX.
ALL HARNESS CONNECTORS VIEWED INTO MATING SURFACE.

EEC-IV Pinpoint Test

TEST STEP		RESULT	ACTION TO TAKE																		
G3	CHECK MAP/BP SENSOR OUTPUT																				
<p>NOTE: Measure several known good MAP/BP sensors on available vehicles. The measured voltage will be typical for your location on the day of testing. Refer to Schematic below</p> <ul style="list-style-type: none"> • Key off • Disconnect MAP/BP sensor from vehicle harness. • Connect MAP/BP tester between the vehicle harness connector and MAP/BP sensor. • Insert MAP/BP tester banana plugs into DVOM. • DVOM on 20 volt scale. • Key on, engine off. • Measure MAP/BP sensor voltage on vehicle. • Is DVOM voltage in range for your altitude? <table border="1"> <thead> <tr> <th>Approximate Altitude (Ft.)</th> <th>Voltage Output (+/- .04 Volts)</th> </tr> </thead> <tbody> <tr> <td>0</td> <td>1.59</td> </tr> <tr> <td>1000</td> <td>1.56</td> </tr> <tr> <td>2000</td> <td>1.53</td> </tr> <tr> <td>3000</td> <td>1.50</td> </tr> <tr> <td>4000</td> <td>1.47</td> </tr> <tr> <td>5000</td> <td>1.44</td> </tr> <tr> <td>6000</td> <td>1.41</td> </tr> <tr> <td>7000</td> <td>1.39</td> </tr> </tbody> </table>		Approximate Altitude (Ft.)	Voltage Output (+/- .04 Volts)	0	1.59	1000	1.56	2000	1.53	3000	1.50	4000	1.47	5000	1.44	6000	1.41	7000	1.39	<p>Yes</p> <p>No</p>	<p>REMOVE MAP/BP tester. RECONNECT MAP/BP sensor. GO to G4 .</p> <p>REPLACE MAP/BP sensor. REMOVE MAP/BP tester and breakout box. RECONNECT all components. RERUN Quick Test. (Refer to TESTING PROCEDURES/QUICK TEST AND DIAGNOSTIC AIDS/DETAILED QUICK TEST PROCEDURES/ KEY ON ENGINE OFF SELF TEST for quick test procedures)</p>
Approximate Altitude (Ft.)	Voltage Output (+/- .04 Volts)																				
0	1.59																				
1000	1.56																				
2000	1.53																				
3000	1.50																				
4000	1.47																				
5000	1.44																				
6000	1.41																				
7000	1.39																				

EEC-IV Pinpoint Test

TEST STEP		RESULT	ACTION TO TAKE
G4	CHECK ACT SENSOR	Yes	Sometime during the last 80 warm-up cycles the TP sensor signal indicated out of range. However, at this time EEC-IV system operating OK. REMOVE breakout box. RECONNECT processor. RERUN Quick Test. (Refer to TESTING PROCEDURES/QUICK TEST AND DIAGNOSTIC AIDS/DETAILED QUICK TEST PROCEDURES/KEY ON ENGINE OFF SELF TEST for quick test procedures)
<p>NOTE: Ambient temperature should be at least 50 degrees F before performing this test, also check for air leaks in front of the ACT sensor. Service as necessary.</p> <ul style="list-style-type: none"> • Key off. • Breakout box installed, processor connected. • Connect DVOM between Test Pin 25 and Test Pin 46 at the breakout box. • DVOM on 20 volt scale. • Monitor voltage as engine warms up. • Does the voltage decrease smoothly and stabilize after engine has reach operating conditions? • Does the voltage decrease smoothly and stabilize after engine has reached operating conditions? <p>NOTE: Refer to voltage chart in Pinpoint Test DA for engine specific values.</p>		No	REPLACE ACT sensor. REMOVE breakout box. RERUN Quick Test. (Refer to TESTING PROCEDURES/QUICK TEST AND DIAGNOSTIC AIDS/DETAILED QUICK TEST PROCEDURES/KEY ON ENGINE OFF SELF TEST for quick test procedures)
G5	VISUALLY INSPECT MAF SENSOR	Yes	GO to G8 .
<p>Continuous Memory Code 184 indicates MAF value is higher than expected.</p> <p>Continuous Memory Code 185 indicates MAF value is lower than expected.</p> <ul style="list-style-type: none"> • Key off. • Check for air leaks between ISC solenoid and MAF sensor. • Inspect MAF sensor for oil contamination. <ul style="list-style-type: none"> — Excessive blow-by — PCV malfunction (refer to Section 15). • Are the above checks OK? 		No	SERVICE as necessary. CLEAR Continuous codes, (Refer to TESTING PROCEDURES/QUICK TEST AND DIAGNOSTIC AIDS/DETAILED QUICK TEST PROCEDURES/CONTINUOUS MEMORY CODES). RERUN Quick Test. (Refer to TESTING PROCEDURES/QUICK TEST AND DIAGNOSTIC AIDS/DETAILED QUICK TEST PROCEDURES/KEY ON ENGINE OFF SELF TEST for quick test procedures)

EEC-IV Pinpoint Test

TEST STEP		RESULT	ACTION TO TAKE
G6	CHECK MAF SENSOR	Yes	<p>Sometime during the last 80 warm-up cycles the MAF sensor signal indicated out of range. However, at this time EEC-IV system is operating OK. REMOVE breakout box. RECONNECT processor. RERUN Quick Test.</p> <p>(Refer to TESTING PROCEDURES/QUICK TEST AND DIAGNOSTIC AIDS/DETAILED QUICK TEST PROCEDURES/KEY ON ENGINE OFF SELF TEST for quick test procedures)</p>
	<ul style="list-style-type: none"> • Key off. • Disconnect processor 60 pin connector. Inspect for damaged or pushed out pins, corrosion, loose wires, etc. Service as necessary. • Install breakout box, and connect processor to breakout box. • Start engine and allow to idle until engine is at normal operating temperature. • Measure voltage between MAF signal and Test Pin 40/60. <p>NOTE: Refer to TESTING PROCEDURES/INTERMITTENT FAULT DIAGNOSIS/DIAGNOSTIC REFERENCE VALUES for engine specific voltages.</p> <ul style="list-style-type: none"> • Is voltage within the acceptable range? 	No	<p>REPLACE MAF sensor. REMOVE breakout box. RECONNECT processor. RERUN Quick Test.</p> <p>(Refer to TESTING PROCEDURES/QUICK TEST AND DIAGNOSTIC AIDS/DETAILED QUICK TEST PROCEDURES/KEY ON ENGINE OFF SELF TEST for quick test procedures)</p>
G7	VISUAL VACUUM CHECKS	Yes	GO to G8 .
	<p>Continuous Memory code 186 indicates pulse width longer than expected (rich).</p> <p>Continuous Memory Code 187 indicates pulse width shorter than expected (lean).</p> <ul style="list-style-type: none"> • Inspect the air cleaner and air inlet ducting. • Check for unmetered air between MAF sensor and ISC bypass air solenoid. • Check all engine vacuum hoses for damage, leaks, cracks, blockage, proper routing, etc. • Are all the above vacuum checks OK? 	No	<p>SERVICE as necessary. RERUN Quick Test.</p> <p>(Refer to TESTING PROCEDURES/QUICK TEST AND DIAGNOSTIC AIDS/DETAILED QUICK TEST PROCEDURES/KEY ON ENGINE OFF SELF TEST for quick test procedures)</p>

EEC-IV Pinpoint Test

TEST STEP		RESULT	ACTION TO TAKE
G8	CHECK FUEL PRESSURE		
<ul style="list-style-type: none"> • Key off. • Install fuel pressure gauge. • Verify manifold vacuum is connected to the fuel pressure regulator if applicable. • Start and run engine at idle. • Refer to fuel specification table below <p>• Is fuel pressure within specification for the engine being tested?</p>		Yes No	GO to G9 . Go to FUEL SYSTEMS for Electric Fuel pump and fuel pressure regulator checks.
G9	CHECK SYSTEMS ABILITY TO HOLD FUEL PRESSURE		
<ul style="list-style-type: none"> • Key on, engine off. • Does fuel pressure remain at specification for 60 seconds? 		Yes No	FOR EFI: GO to H7 . FOR SEFI: GO to G10 . GO to FUEL SYSTEMS.
G10	CYLINDER BALANCE TEST		
<ul style="list-style-type: none"> • Run the Engine Running Self-Test. • After the last repeated code, wait 5-10 seconds. • "Goose" throttle lighty (not wide-open-throttle). • Cylinder Balance Test will be performed. Time of test is approximately 2-3 minutes. • Is code 90 present? 		Yes No	GO to G5 . GO to PINPOINT TEST H, STEP H4.

EEC-IV Pinpoint Test

FUEL PRESSURE SPECIFICATION TABLES		
THE FUEL SYSTEM WILL REMAIN PRESSURIZED WHEN THE ENGINE IS NOT RUNNING. TO PREVENT INJURY OR FIRE USE CAUTION WHEN WORKING ON THE FUEL SYSTEM.		
ENGINE MODE \ ENGINE APPLICATION	4.9L EFI	All Other Applications
ENGINE RUNNING	45 - 60 PSI 310 - 415 kPa	30 - 45 PSI 210 - 310 kPa
KEY ON ENGINE OFF	50 - 60 PSI 345 - 415 kPa	35 - 45 PSI 240 - 310 kPa

Note: Maximum fuel pressure is obtainable at WOT or the vacuum hose removed from the fuel pressure regulator.

EEC-IV Pinpoint Test

FUEL PRESSURE SPECIFICATION TABLES

THE FUEL SYSTEM WILL REMAIN PRESSURIZED WHEN THE ENGINE IS NOT RUNNING. TO PREVENT INJURY OR FIRE USE CAUTION WHEN WORKING ON THE FUEL SYSTEM.

ENGINE MODE \ ENGINE APPLICATION	4.9L EFI	All Other Applications
ENGINE RUNNING	45 - 60 PSI 310 - 415 kPa	30 - 45 PSI 210 - 310 kPa
KEY ON ENGINE OFF	50 - 60 PSI 345 - 415 kPa	35 - 45 PSI 240 - 310 kPa

Note: Maximum fuel pressure is obtainable at WOT or the vacuum hose removed from the fuel pressure regulator.

EEC-IV Pinpoint Test

**INJECTOR BANK RESISTANCE
SPECIFICATION TABLE # 1 (NOT FOR SEFI)**

VALUES ARE IN OHMS

2.3L	2.9L/3.0L 4.9L	5.0L/5.8L 7.0L/7.5L
7.0 - 9.5	5.0 - 6.5	3.0 - 4.0

**SINGLE INJECTOR RESISTANCE
SPECIFICATION TABLE # 2**

TRUCK ENGINES
VALUES ARE IN OHMS

2.3L/3.0L	ALL OTHER ENGINES
15.0 - 18.0	13.0 - 16.0

EEC-IV Pinpoint Test

Pinpoint Test Schematic

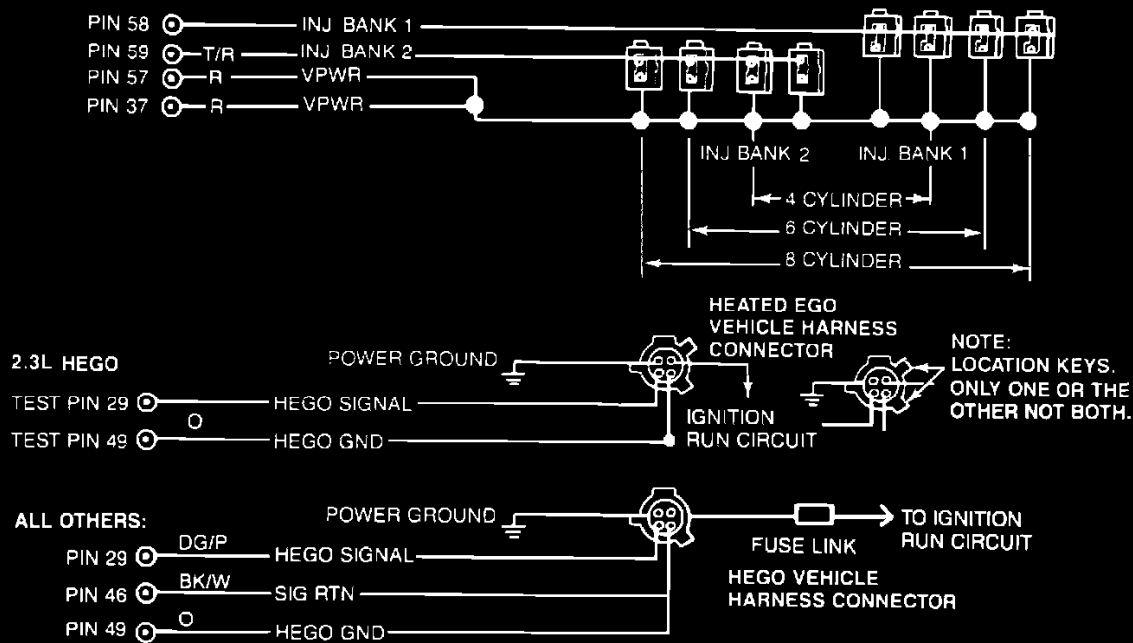

Test Pin 58	INJ BANK 1
Application	Wire Color
2.3L MA Truck	LG/W
2.9L MA Truck	LG/W
All Others	T/O

Test Pin 59	INJ BANK 2
Application	Wire Color
All	T/R

*TEST PINS LOCATED ON BREAKOUT BOX.
ALL HARNESS CONNECTORS VIEWED INTO MATING SURFACE.

Note

You should enter this Pinpoint Test only when you have been directed here from Quick Test or Pinpoint Test S.

Remember

To prevent the replacement of good components, be aware that the following non-EEC areas may be at fault:

- Ignition System
- Evaporative Emission System
- Positive Crankcase Ventilation System
- ThermaCTOR System
- Exhaust Gas Recirculation System
- Air Intake System/Filter
- Fuel Engine Oil Contamination
- Electrical System
- Fuel System
- Intake, Manifold, Supercharger, Intercooler Leaks
- Exhaust Manifold System Leak/Plugged
- Engine, Cooling System

To clarify how the system works for lean indication the system could be running rich i.e. black smoke, etc. For rich indication the system could be running lean i.e. lack of fuel, etc. The HEGO sensor is reacting only with the Oxygen in the exhaust gases. Consequently, the vehicle has to be driven a minimum of 5 miles at 55 mph before running Self Test and verify the repair.

This Pinpoint Test is intended to diagnose only the following:

- HEGO Sensor/heater
- HEGO Signal and Ground Circuit
- HEGO Sensor Connection
- Vacuum Systems
- Fuel Injector
- Fuel Injector electrical circuits
- Processor Assembly
- Harness circuits: HEGO GND, HEGO, INJ. 1 – 8, VPWR and SIG RTN

EEC-IV Pinpoint Test

TEST STEP			RESULT	ACTION TO TAKE
H1 CHECK FOR CONTAMINATED ENGINE OIL				
Service Code	HEGO Sensor Orientation	Fault Definition		
41/172r 91/136r 176c	right or rear left or front left or front	HEGO lean, lack or switching.		
42/173r 92/137r 177c	right or rear left or front left or front	HEGO rich, lack of switching.		
144/41c 139/91c	right or rear left or front	no HEGO switch detected.		
171c 175c	right or rear left or front	adaptive fuel limit reached, lack of HEGO switching.		
174c 178c	right or rear left or front	lazy HEGO, slow to switch.		
<p>Possible Causes:</p> <ul style="list-style-type: none"> — Fuel injectors. — Thermactor. — Vacuum — MAP sensor. — HEGO sensor. — PCV. — CANP. 				
<ul style="list-style-type: none"> • Key off. • Remove the PCV valve from the valve cover. Inspect both rocker cover hole and PCV for damage, sludge build up, blockage and movement of valve plunger. Service as necessary. • Run Engine Running Self Test. (Refer to TESTING PROCEDURES/QUICK TEST AND DIAGNOSTIC AIDS/DETAILED QUICK TEST PROCEDURES/KEY ON ENGINE RUNNING SELF TEST for test procedures) 			Yes	REINSTALL PCV valve. GO to PINPOINT TEST H, STEP H2.
<p>NOTE: For a No Start Go directly to PINPOINT TEST H, STEP H2</p>			No	CHANGE engine oil and filter. REINSTALL PCV valve. DRIVE vehicle 5miles/55mph. RERUN Quick Test. (Refer to TESTING PROCEDURES/QUICK TEST AND DIAGNOSTIC AIDS/DETAILED QUICK TEST PROCEDURES/KEY ON ENGINE OFF SELF TEST for quick test procedures)
<ul style="list-style-type: none"> • Are any of the above codes present? 				

EEC-IV Pinpoint Test

TEST STEP		RESULT	ACTION TO TAKE
H2	CHECK FUEL PRESSURE		
<div style="border: 1px solid black; padding: 2px; width: fit-content; margin-bottom: 10px;">WARNING</div> <p>THE FUEL SYSTEM WILL REMAIN PRESSURIZED WHEN ENGINE IS NOT RUNNING. TO PREVENT INJURY OR FIRE USE CAUTION WHEN WORKING ON THE FUEL SYSTEM.</p> <ul style="list-style-type: none"> • Key off. • Install fuel pressure gauge. • Verify that manifold vacuum is connected to the fuel pressure regulator if applicable. <ul style="list-style-type: none"> — If engine will start: • Start and run engine at idle. Note fuel pressure. • Refer to Fuel Pressure Specification Table. <ul style="list-style-type: none"> — If engine will not start: • Cycle the key off and on several times. Note fuel pressure. • Refer to Fuel Pressure Specification Table. • Is fuel pressure within specification for the engine being tested? 		<p>Yes ▶</p> <p>No ▶</p>	<p>GO to H3 .</p> <p>Go to FUEL SYSTEM for Electric Fuel Delivery System Diagnosis.</p>
H3	CHECK SYSTEM'S ABILITY TO HOLD FUEL PRESSURE		
<ul style="list-style-type: none"> • Pressurize fuel system per step H2 . • Visually look for fuel leaking at the injector O-ring, fuel pressure regulator, and the fuel lines to the fuel charging assembly. Service as necessary. • Key on, engine off. • With a stethoscope listen for leaking fuel injectors. • Does fuel pressure remain at specification for 60 seconds? 		<p>Yes ▶</p> <p>No ▶</p>	<p>For No Starts: GO to H4 .</p> <p>For Service Codes or other Symptoms:</p> <ul style="list-style-type: none"> — EFI: GO to H5 . — SEFI: GO to H6 . <p>GO to FUEL SYSTEMS for, Electric Fuel Delivery System Diagnosis.</p>

EEC-IV Pinpoint Test

TEST STEP		RESULT	ACTION TO TAKE
H4	FUEL DELIVERY TEST	Yes	The EEC-IV system is not the cause of the No Start. REMOVE the fuel pressure gauge. RECONNECT the inertia switch. REFER to TESTING PROCEDURES/ DIAGNOSTIC ROUTINES for other No Start routines.
	<ul style="list-style-type: none"> • Key off. • Fuel pressure gauge installed. • Pressurize fuel system per step H2 . • Locate and disconnect the inertia switch. • Crank engine for 5 seconds. • Does pressure drop greater than 5 psi. (34 kPa) by the end of the 5 second crank cycle? 	No	REMOVE fuel pressure gauge. RECONNECT inertia switch. For EFI: GO to H7 . For SEFI: GO to H8 .
H5	CYLINDER BALANCE TEST: EFI ENGINES	Yes	For Symptoms or Codes 41/172, 91/136, 176: GO to H13 . For Codes 42/173, 92/137, 177: GO to H24 . For All Others: GO to H14 .
	<ul style="list-style-type: none"> • Connect tachometer to engine. Run engine at idle. • Disconnect and reconnect the injectors one at a time: Note rpm drop for each injector. • Does each injector produce a momentary drop in rpm? <p>NOTE: ISC will attempt to re-establish rpm.</p>	No	GO to H7 .

EEC-IV Pinpoint Test

TEST STEP		RESULT	ACTION TO TAKE							
H6	CYLINDER BALANCE TEST SEFI ENGINES									
<p>The Cylinder Balance Test switches each injector OFF and ON one at a time. Service codes correspond to the cylinder number, (e.g. Service Code 30 indicates a problem with cylinder No. 3, a Service Code 90 indicates a pass.) The Cylinder Balance Test is designed to aid in the detection of a weak or non-contributing cylinder. The Pinpoint Test Steps are designed to isolate only EEC-IV related problems.</p> <p>Refer to TESTING PROCEDURES/QUICK TEST AND DIAGNOSTIC AIDS/DETAILED QUICK TEST PROCEDURES/KEY ON ENGINE RUNNING SELF TEST for detailed info. about Cylinder Balance Test</p> <ul style="list-style-type: none"> • Run the Engine Running Self-Test. • After the last repeated code, wait 5-10 seconds. • "Goose" throttle lightly (not wide-open-throttle). • Cylinder Balance Test will be performed. Time of test is approximately 2-3 minutes. • Is a Cylinder balance Fault Code present? 		<p>No</p> <p>Yes</p>	<p>For Symptoms or Service Code 41/172, 91/136, 176: GO to H13 .</p> <p>For Service Code 42/173, 92/137, 177: GO to H24 .</p> <p>For All Others: GO to H14 .</p> <p>GO to H8 .</p>							
CYLINDER BALANCE TABLE SERVICE CODE VS. CYLINDER										
SERVICE CODE	90	10	20	30	40	50	60	70	80	77/538
CYLINDER/INJECTOR NUMBER	PASS	1	2	3	4	5	6	7	8	RERUN TEST*
<p>* If throttle is touched (moved) during Cylinder Balance Test, Service Code 77/538 will appear, indicating test was not completed.</p> <p>Service Code 538 could also be output if a Continuous Memory Code 214(CID) is present. If Continuous Memory Code 214 is present refer to the appropriate code chart in Quick Test for service direction.</p>										

EEC-IV Pinpoint Test

TEST STEP		RESULT	ACTION TO TAKE
H7	CHECK RESISTANCE OF INJECTOR(S) AND HARNESS EFI ENGINES.		
<ul style="list-style-type: none"> • Key off. • Disconnect processor 60 pin connector. Inspect for damaged or pushed out pins, corrosion, loose wires, etc. Service as necessary. <p>Note: This erases Continuous Memory.</p> <ul style="list-style-type: none"> • Install breakout box, leave processor disconnected. • Measure resistance of INJECTOR BANK 1 between Test Pin 37 and Test Pin 58 at the breakout box. Record resistance. • Measure resistance of INJECTOR BANK 2 between Test Pin 37 and Test Pin 59 at the breakout box. Record resistance. • Refer to Injector Resistance Specification Table #1. • Is each resistance within specification for the appropriate engine? 		<p>Yes</p> <p>No</p>	<p>GO to H12 .</p> <p>For NO START: SERVICE open in VPWR circuit.</p> <p>For Others: GO to H9</p>
H8	CHECK RESISTANCE OF INJECTOR(S) AND HARNESS SEFI ENGINES		
<ul style="list-style-type: none"> • Key off. • Disconnect processor 60 pin connector. Inspect for damaged or pushed out pins, corrosion, loose wires, etc. Service as necessary. <p>Note: This erases Continuous Memory.</p> <ul style="list-style-type: none"> • Install breakout box, leave processor disconnected. • Measure resistance between the suspect INJECTOR circuit Test Pin and Test Pin 37 at the breakout box. Record resistance. • For No Starts: • Pick any injector and measure resistance between that INJECTOR circuit's Test Pin and Test Pin 37 at the breakout box. Record resistance. • Refer to Injector Resistance Specification Table #2. • Is each resistance within specification for the appropriate engine? 		<p>Yes</p> <p>No</p>	<p>GO to H12 .</p> <p>For NO START: SERVICE open in VPWR circuit.</p> <p>For Others: GO to H9</p>

EEC-IV Pinpoint Test

TEST STEP		RESULT	ACTION TO TAKE
H9	CHECK CONTINUITY OF FUEL INJECTOR HARNESS		
<ul style="list-style-type: none"> • Key off. • Breakout box installed, processor disconnected. • Disconnect injector vehicle harness connector at the injectors. • Measure resistance between Test Pin 37/57 at the breakout box and the VPWR pin at each injector vehicle harness connector. • Refer to the Pin Point Test Schematic for the appropriate injector pin identification. • Measure resistance between the injector test pin(s) at the breakout box and the same injector circuit signal pin at the each injector vehicle harness connector. • Is each resistance less than 5 ohms? 		<p>Yes</p> <p>No</p>	<p>GO to H10 .</p> <p>SERVICE open circuit. REMOVE breakout box. RECONNECT processor and injectors. RECONNECT processor and injectors. DRIVE vehicle 5 miles/55mph. RERUN Quick Test. (Refer to TESTING PROCEDURES/ QUICK TEST AND DIAGNOSTIC AIDS/ DETAILED QUICK TEST PROCEDURES/ KEY ON ENGINE OFF SELF TEST for quick test procedures.)</p>
H10	CHECK INJECTOR HARNESS CIRCUIT FOR SHORT TO POWER OR GROUND		
<ul style="list-style-type: none"> • Key off. • Breakout box installed, processor disconnected. • Fuel injector vehicle harness disconnected. • Refer to the Pinpoint Test Schematic for the appropriate injector pin identification. • Measure resistance between the injector test pin(s) and Test Pin 37/57, 40, 46, and 60 at the breakout box. • Measure resistance between the injector test pin(s) at the breakout box and chassis ground. • Is each resistance greater than 10,000 ohms? 		<p>Yes</p> <p>No</p>	<p>For SEFI: REPLACE injector per cyl. balance test fault code. RERUN Quick Test. (Refer to TESTING PROCEDURES/ QUICK TEST AND DIAGNOSTIC AIDS/ DETAILED QUICK TEST PROCEDURES/ KEY ON ENGINE OFF SELF TEST for quick test procedures.)</p> <p>For EFI: GO to H11</p> <p>SERVICE short circuit. REMOVE breakout box. RECONNECT processor and injectors. DRIVE vehicle 5 miles/55mph. RERUN Quick Test. (Refer to TESTING PROCEDURES/ QUICK TEST AND DIAGNOSTIC AIDS/ DETAILED QUICK TEST PROCEDURES/ KEY ON ENGINE OFF SELF TEST for quick test procedures.)</p>

EEC-IV Pinpoint Test

TEST STEP		RESULT	ACTION TO TAKE
H11	ISOLATE FAULTY INJECTOR CIRCUIT		
<ul style="list-style-type: none"> • Key off. • Breakout box installed, processor disconnected. • Disconnect all injectors on suspect bank. • DVOM on 200 ohm scale. • Connect one injector and measure resistance between Test Pin 37 and either Test Pin 58 or 59 as appropriate. • Disconnect that injector and repeat process for each of the remaining injectors. • Refer to Injector Resistance Specification Table #2. • Is each resistance within specification for the appropriate engine? 		<p>Yes ▶</p> <p>No ▶</p>	<p>GO to H12 .</p> <p>REPLACE injector. REMOVE breakout box. RECONNECT processor and injectors. DRIVE vehicle 5 miles/55mph. RERUN Quick Test. (Refer to TESTING PROCEDURES/QUICK TEST AND DIAGNOSTIC AIDS/DETAILED QUICK TEST PROCEDURES/KEY ON ENGINE OFF SELF TEST for quick test procedures)</p>
H12	CHECK INJECTOR DRIVER SIGNAL		
<p>Requires standard non-powered 12 volt test lamp.</p> <ul style="list-style-type: none"> • Key off. • Breakout box installed. • Connect processor to breakout box. <p>For EFI:</p> <ul style="list-style-type: none"> — Connect test lamp between Test Pin 37 and Test Pin 58 at the breakout box. — Connect test lamp between Test Pin 37 and 59 at the breakout box. <p>For SEFI:</p> <ul style="list-style-type: none"> — Connect test lamp between Test Pin 37 and the suspect injectors Test Pin at the breakout box. <p>• Crank or start engine.</p> <p>NOTE: Properly operating systems will show a dim glow on the lamp.</p> <ul style="list-style-type: none"> • Is glow on lamp dim? 		<p>Yes ▶</p> <p>No ▶</p>	<p>REMOVE breakout box. RECONNECT processor.GO to FUEL SYSTEMS for injector testing instructions. Also refer to IGNITION SYSTEMS for other possible causes. After any servicing, DRIVE vehicle 5 miles/55mph. RERUN Quick Test and Cylinder Balance Test. (Refer to TESTING PROCEDURES/QUICK TEST AND DIAGNOSTIC AIDS/DETAILED QUICK TEST PROCEDURES/KEY ON ENGINE RUNNING SELF TEST for test procedures)</p> <p>No light/Bright light: REPLACE processor. REMOVE breakout box. DRIVE vehicle 5 miles/55mph. RERUN Quick Test. (Refer to TESTING PROCEDURES/QUICK TEST AND DIAGNOSTIC AIDS/DETAILED QUICK TEST PROCEDURES/KEY ON ENGINE OFF SELF TEST for quick test procedures)</p>

EEC-IV Pinpoint Test

TEST STEP	RESULT	ACTION TO TAKE
<p>H13 CHECK THERMACTOR OPERATION</p> <p>NOTE: If vehicle is equipped with Pulse-Air or no Thermactor System, ignore this step and Go to H14</p> <p>With dual HEGO, code 41/172 refers to right or rear HEGO, code 91/136, 176 refers to left or front HEGO.</p> <p>HEGO always lean could be caused by: Thermactor air being diverted upstream from the HEGO sensor.</p> <ul style="list-style-type: none"> • Key off. • Disconnect the thermactor air hose(s) from the thermactor pump so that thermactor air is bypassed to atmosphere during testing. • Run Engine Running Self Test. <p>(Refer to TESTING PROCEDURES/QUICK TEST AND DIAGNOSTIC AIDS/DETAILED QUICK TEST PROCEDURES/KEY ON ENGINE OFF SELF TEST and ENGINE RUNNING SELF TEST for test procedures).</p> <ul style="list-style-type: none"> • Are codes 41/172, 91/136, 176 present? 	<p>Yes</p> <p>No</p>	<p>▶ RECONNECT Thermactor Air Hose. GO to H14 .</p> <p>▶ GO to EMISSION CONTROLS for Thermactor systems diagnosis.</p>
<p>H14 CHECK HEGO INTEGRITY</p> <p>HEGO always lean, slow to switch or lack of switching; fuel at adaptive limit could be caused by:</p> <ul style="list-style-type: none"> — Moisture inside the HEGO sensor/harness connector resulting in a short to ground. — HEGO sensor being coated with contaminants. — HEGO circuit open. — HEGO circuit shorted to ground. <ul style="list-style-type: none"> • Key off. • Inspect the HEGO harness for chaffing, burnt or other indications of damage. Service as necessary. • Inspect HEGO sensor and connector for indication of submerging to water. Service as necessary. • Run engine at 2,000 rpm for 2 minutes. • Key off. • Run Engine Running Self Test. <p>(Refer to TESTING PROCEDURES/ QUICK TEST AND DIAGNOSTIC AIDS/DETAILED QUICK TEST PROCEDURES/KEY ON ENGINE OFF SELF TEST and ENGINE RUNNING SELF TEST for test procedures).</p> <ul style="list-style-type: none"> • Are fault codes present? 	<p>Yes</p> <p>No</p>	<p>▶ For engines with: — MAP sensor GO to H15 .</p> <p>— MAF sensor GO to H16 .</p> <p>▶ GO to H21 .</p>

EEC-IV Pinpoint Test

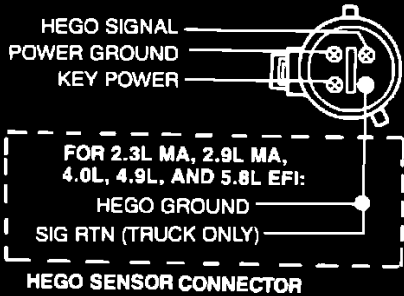
TEST STEP		RESULT	ACTION TO TAKE
H15	CHECK HEGO SENSOR ON ENGINES WITH MAP SENSORS		
<p>NOTE: Vacuum/air leaks in non-EEC-IV areas could also cause Code 41/91. Check for:</p> <ul style="list-style-type: none"> — Leaking vacuum actuator (e.g. A/C control motor) — Engine sealing — EGR system — PCV system — Lead contaminated HEGO sensor <ul style="list-style-type: none"> • Key off. • Disconnect appropriate HEGO sensor from vehicle harness. <p>For 4 wire HEGO:</p> <ul style="list-style-type: none"> — Connect DVOM to HEGO SIGNAL and HEGO GND at the HEGO sensor connector. <p>For 3 wire HEGO:</p> <ul style="list-style-type: none"> — Connect DVOM to HEGO SIGNAL at the sensor and battery negative post. <ul style="list-style-type: none"> • Disconnect and plug vacuum line at MAP sensor. • DVOM on 20 volt scale. • Start engine and apply 10-14 in. Hg. (33-46 kPa) to MAP sensor. • Run engine at approximately 2,000 rpm for 2 minutes. • Does the DVOM indicate greater than 0.5 volts within 2 minutes? 		<p>Yes</p> <p>No</p>	<p>GO to H17 .</p> <p>REPLACE HEGO sensor. RECONNECT MAP sensor vacuum line. RERUN Quick Test. (Refer to TESTING PROCEDURES/QUICK TEST AND DIAGNOSTIC AIDS/DETAILED QUICK TEST PROCEDURES/KEY ON ENGINE OFF SELF TEST for quick test procedures)</p>
 <p>HEGO SIGNAL</p> <p>POWER GROUND</p> <p>KEY POWER</p> <p>FOR 2.3L MA, 2.9L MA, 4.0L, 4.9L, AND 5.8L EFI:</p> <p>HEGO GROUND</p> <p>SIG RTN (TRUCK ONLY)</p> <p>HEGO SENSOR CONNECTOR</p>			

EEC-IV Pinpoint Test

TEST STEP		RESULT	ACTION TO TAKE
H16	CHECK HEGO SENSOR ON ENGINES WITH MAF		
<p>NOTE: The purpose of this test is to verify the HEGO sensor can generate greater than 0.5 volts during Engine Running Self-Test.</p> <p>Any Vacuum/air leaks in non-EEC-IV areas could also cause Code 41/91. Check for:</p> <ul style="list-style-type: none"> — Leaking vacuum actuator (e.g. A/C control motor). — Engine sealing. — EGR system. — PCV system. — Unmetered air leak between Mass Air Flow sensor and throttle body. — Lead contaminated HEGO sensor. <ul style="list-style-type: none"> • Key off. • Disconnect appropriate HEGO sensor from vehicle harness. <p>For 4 wire HEGO:</p> <ul style="list-style-type: none"> — Connect DVOM to HEGO SIGNAL and HEGO GND at the HEGO sensor connector. <p>For 3 wire HEGO:</p> <ul style="list-style-type: none"> — Connect DVOM to HEGO SIGNAL at the sensor and battery negative post. • DVOM on 20 volt scale. • Rerun Engine Running Self-Test and monitor HEGO sensor voltage. • Does DVOM Indicate greater than 0.5 volts at the end of Self-Test? 		<p>Yes</p> <p>No</p>	<p>GO to H17 .</p> <p>REPLACE HEGO sensor. RERUN Quick Test. (Refer to TESTING PROCEDURES/QUICK TEST AND DIAGNOSTIC AIDS/DETAILED QUICK TEST PROCEDURES/KEY ON ENGINE OFF SELF TEST for quick test procedures)</p>

EEC-IV Pinpoint Test

TEST STEP		RESULT	ACTION TO TAKE
H17	CHECK CONTINUITY OF HEGO SIGNAL AND HEGO GROUND		
<ul style="list-style-type: none"> • Key off. • Disconnect processor from breakout box. • Disconnect suspect HEGO sensor from vehicle harness. Inspect both ends of connector for damaged or pushed out pins, moisture, corrosion, loose wires, etc. Service as necessary. • Measure resistance between HEGO SIGNAL Test Pin at the breakout box and HEGO SIGNAL at the vehicle harness connector. <p>For 3-wire HEGO:</p> <ul style="list-style-type: none"> — Measure resistance between HEGO GROUND Test Pin at the breakout box and battery negative post. <p>For 4-wire HEGO:</p> <ul style="list-style-type: none"> — Measure resistance between HEGO GROUND Test Pin at the breakout box and HEGO GND at the vehicle harness connector. — Where applicable measure resistance between HEGO GND and SIG RTN at the breakout box. <ul style="list-style-type: none"> • Is each resistance less than 5.0 ohms? 		<p>Yes</p> <p>No</p>	<p>GO to H18</p> <p>SERVICE open circuit. REMOVE breakout box. RECONNECT processor, HEGO sensor, and any other components that have been disconnected. DRIVE vehicle 5 miles/55 mph.</p> <p>RERUN Quick Test. (Refer to TESTING PROCEDURES/QUICK TEST AND DIAGNOSTIC AIDS/DETAILED QUICK TEST PROCEDURES/KEY ON ENGINE OFF SELF TEST for quick test procedures)</p>
H18	CHECK HEGO CIRCUIT FOR SHORT TO GROUND		
<ul style="list-style-type: none"> • Key off. • Breakout box installed, processor disconnected. • HEGO disconnected. • Measure resistance between the HEGO SIGNAL Test Pin at the breakout box and Test Pins 40, 46 and 49 at the breakout box. <ul style="list-style-type: none"> • Is each resistance greater than 10,000 ohms? 		<p>Yes</p> <p>No</p>	<p>Go to H19</p> <p>SERVICE short circuit. REMOVE breakout box. RECONNECT processor, HEGO sensor, and any other components that are disconnected. DRIVE vehicle 5 miles/55 mph.</p>

EEC-IV Pinpoint Test

TEST STEP		RESULT	ACTION TO TAKE
H19	CHECK HEGO SENSOR FOR SHORT TO GROUND		
<ul style="list-style-type: none"> • Key off. • Breakout box installed, processor disconnected. • HEGO disconnected. • DVOM on 200,000 ohm scale. • Measure resistance between PWR GND and HEGO SIGNAL at the HEGO sensor connector. • For 3.8L and truck with 4 wire HEGO: <ul style="list-style-type: none"> — Measure resistance between PWR GND, HEGO GND SIG RTN and HEGO SIG at the HEGO sensor connector. • Is resistance greater than 10,000 ohms? 		Yes	<p>For Codes: 144/41C; 139/91C, 171, 174, 175 or 178, GO to H90</p> <p>For other codes:</p> <ul style="list-style-type: none"> — MAP sensor GO to H20 — MAF Sensor: REMOVE breakout box. RECONNECT HEGO sensor. REPLACE processor. DRIVE vehicle 5 miles/55 mph. RERUN Quick Test. <p>(Refer to TESTING PROCEDURES/QUICK TEST AND DIAGNOSTIC AIDS/DETAILED QUICK TEST PROCEDURES/KEY ON ENGINE OFF SELF TEST for quick test procedures)</p>
		No	<p>REPLACE HEGO sensor. REMOVE breakout box. RECONNECT processor. DRIVE vehicle 5 miles/55 mph. RERUN Quick Test.</p> <p>(Refer to TESTING PROCEDURES/QUICK TEST AND DIAGNOSTIC AIDS/DETAILED QUICK TEST PROCEDURES/KEY ON ENGINE OFF SELF TEST for quick test procedures)</p>

EEC-IV Pinpoint Test

TEST STEP		RESULT	ACTION TO TAKE
H20	ATTEMPT TO ELIMINATE CODE 41/172, 91/136 or 176 ON ENGINES WITH MAP SENSOR	Yes	REMOVE breakout box. RECONNECT MAP sensor vacuum line. If engine runs rough, GO to. All others PINPOINT TEST S, STEP S2. REPLACE processor. DRIVE vehicle 5miles/55mph. RERUN Quick Test. (Refer to TESTING PROCEDURES/QUICK TEST AND DIAGNOSTIC AIDS/DETAILED QUICK TEST PROCEDURES/KEY ON ENGINE OFF SELF TEST for quick test procedures)
	<ul style="list-style-type: none"> • Key off. • Breakout box installed. • Disconnect and plug MAP vacuum line. • Connect processor to breakout box. • Reconnect HEGO sensor. • Start engine and apply 10-14 in-Hg (3-46 kPa) vacuum to MAP sensor. • Run engine at approximately 2000 rpm for 2 minutes. Allow engine to return to idle. • Rerun Engine Running Self-Test. (Refer to TESTING PROCEDURES/QUICK TEST AND DIAGNOSTIC AIDS/DETAILED QUICK TEST PROCEDURES/KEY ON ENGINE OFF SELF TEST and ENGINE RUNNING SELF TEST for test procedures.) <p>NOTE: If you are here for Continuous Memory Codes the vehicle has to be driven 5 miles/55 mph.</p> <ul style="list-style-type: none"> • Is Code 41/172, 91/136 or 176 still present (ignore all other codes)? 	No	REMOVE breakout box. RECONNECT processor and MAP sensor vacuum line. HEGO sensor input OK. Fuel delivery is OK. Problem is in an area common to all cylinders, i.e. air/vacuum leak, fuel contamination, EGR Thermactor, CHECK MAP frequency, IGN System, etc. SERVICE as necessary.

EEC-IV Pinpoint Test

TEST STEP		RESULT	ACTION TO TAKE
H21	CHECK RESISTANCE OF HEATER ELEMENT ON HEGO		
<ul style="list-style-type: none"> • Key off. • Disconnect suspect HEGO sensor from vehicle harness. • Inspect both ends of the connector for damaged or pushed out pins, moisture, corrosion, loose wires, etc. Service as necessary. • Measure resistance between KPWR circuit and PWR GND circuit at HEGO sensor connector. <ul style="list-style-type: none"> — Hot to warm resistance specification is 5.0 to 30.0 ohms. — Room temperature resistance specification is 2.0 to 5.0 ohms. • Is resistance within specification? 		<p>Yes</p> <p>No</p>	<p>GO to H22 .</p> <p>REPLACE HEGO sensor. RERUN Quick Test. (Refer to TESTING PROCEDURES/QUICK TEST AND DIAGNOSTIC AIDS/DETAILED QUICK TEST PROCEDURES/KEY ON ENGINE OFF SELF TEST for quick test procedures)</p>

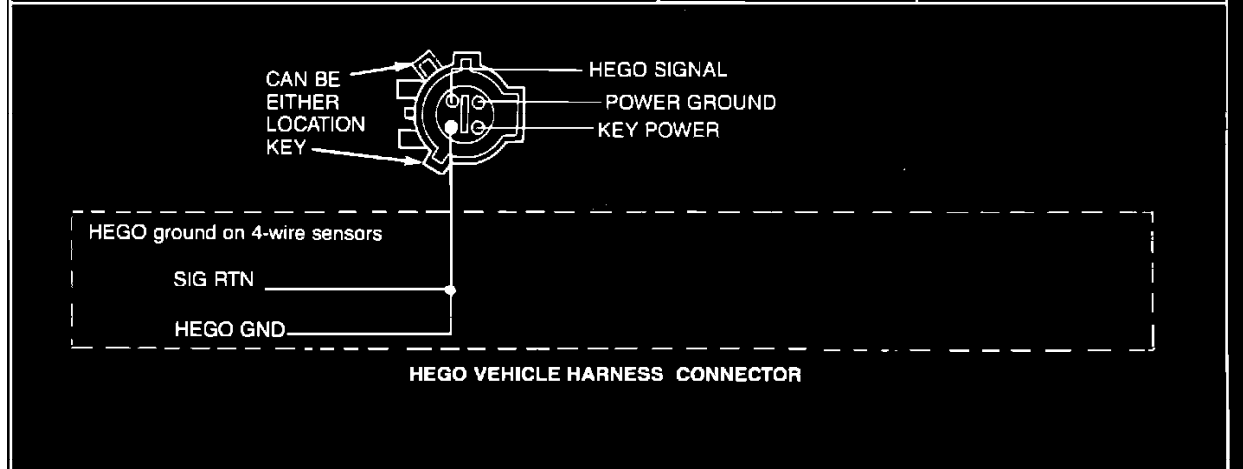

EEC-IV Pinpoint Test

TEST STEP		RESULT	ACTION TO TAKE
H22	CHECK FOR POWER AT HEGO HARNESS CONNECTOR		
<ul style="list-style-type: none"> • Key on, engine off. • HEGO disconnected. • Measure voltage between KEY POWER circuit and PWR GND circuit at the HEGO vehicle harness connector. • Is voltage greater than 10.5 volts? 		Yes	<p>RECONNECT HEGO sensor. HEGO sensor system OK.</p> <p>Fuel delivery is OK. HEGO sensor may have cooled prior to Engine Running Self-Test. If symptom persists, problem is in an area common to all cylinders, i.e. air/vacuum leak, fuel contamination, EGR Thermactor, MAP. CHECK MAP frequency, ignition system. etc. SERVICE as necessary.</p>
		No	GO to H23

HEGO VEHICLE HARNESS CONNECTOR

EEC-IV Pinpoint Test

TEST STEP		RESULT	ACTION TO TAKE
H23	CHECK CONTINUITY OF POWER GROUND CIRCUIT	Yes	SERVICE open in KEY POWER circuit. RECONNECT HEGO sensor. RERUN Quick Test. (Refer to TESTING PROCEDURES/QUICK TEST AND DIAGNOSTIC AIDS/DETAILED QUICK TEST PROCEDURES/KEY ON ENGINE OFF SELF TEST for quick test procedures)
	<ul style="list-style-type: none"> • Key off. • HEGO disconnected. • Measure resistance between PWR GND circuit at the HEGO vehicle harness connector and battery negative post. • Is resistance less than 5.0 ohms? 	No	SERVICE open in PWR GND circuit. RECONNECT HEGO sensor. RERUN Quick Test. (Refer to TESTING PROCEDURES/QUICK TEST AND DIAGNOSTIC AIDS/DETAILED QUICK TEST PROCEDURES/KEY ON ENGINE OFF SELF TEST for quick test procedures)

EEC-IV Pinpoint Test

TEST STEP		RESULT	ACTION TO TAKE
H24	CHECK HEGO SIGNAL FOR SHORT TO POWER		
<p>With dual HEGO, code 42/173 refers to right or rear HEGO; code 92/137, 177 refers to left or front HEGO.</p> <p>HEGO always rich could be caused by:</p> <ul style="list-style-type: none"> — Moisture inside HEGO harness connector resulting in a short to power. — HEGO circuit shorted to power. <ul style="list-style-type: none"> • Key off. • Disconnect the suspect HEGO sensor from vehicle harness. • Inspect both ends of the connector for damaged or pushed out pins, moisture, corrosion, loose wires, etc. Service as necessary. • Key on, engine off. • Measure voltage between HEGO SIG and PWR GND at the HEGO vehicle harness connector. • Is voltage less than 0.5 volts? 		<p>Yes</p> <p>No</p>	<p>GO to H26 .</p> <p>GO to H25 .</p>
<p>The diagram shows a circular HEGO vehicle harness connector with four terminals. Labels indicate: 'CAN BE EITHER LOCATION KEY' pointing to the top-left terminal; 'HEGO SIGNAL' pointing to the top-right terminal; 'POWER GROUND' pointing to the bottom-right terminal; and 'KEY POWER' pointing to the bottom-left terminal. Below the connector, a dashed box labeled 'HEGO VEHICLE HARNESS CONNECTOR' contains two terminals: 'SIG RTN' and 'HEGO GND'. A line connects the 'HEGO GND' terminal to the 'POWER GROUND' terminal of the connector above.</p>			

EEC-IV Pinpoint Test

TEST STEP		RESULT	ACTION TO TAKE
H25	CHECK FOR SHORT TO POWER	Yes	<p>REPLACE processor. REMOVE breakout box. RECONNECT HEGO. DRIVE vehicle 5 miles/ 55 mph. RERUN Quick Test. (Refer to TESTING PROCEDURES/QUICK TEST AND DIAGNOSTIC AIDS/DETAILED QUICK TEST PROCEDURES/KEY ON ENGINE OFF SELF TEST for quick test procedures)</p>
	<ul style="list-style-type: none"> • Key off. • Inspect HEGO GND and HEGO Signal harness for chaffing, burnt or other indications of short to power. Service as necessary. • Disconnect processor 60 pin connector. Inspect for damaged, or pushed out pins, corrosion, loose wires etc. Service as necessary. • Install breakout box, leave processor disconnected. • Suspect HEGO disconnected. • Measure resistance between HEGO SIG, and KEYPWR at the breakout box. • Is the resistance greater than 10,000 ohms? 	No	<p>SERVICE short to power. REMOVE breakout box. RECONNECT processor. DRIVE vehicle 5 miles/55mph. RERUN Quick Test. (Refer to TESTING PROCEDURES/QUICK TEST AND DIAGNOSTIC AIDS/DETAILED QUICK TEST PROCEDURES/KEY ON ENGINE OFF SELF TEST for quick test procedures)</p>

EEC-IV Pinpoint Test

TEST STEP		RESULT	ACTION TO TAKE
H26	CHECK HEGO SENSOR FOR SHORT TO IGNITION RUN CIRCUIT	Yes	<p>For Codes 42/173, 92/137, 177; GO to H27 .</p> <p>For Codes 171, 174, 175, 178: MAP sensor: GO to H28 . MAF sensor: GO to H30 .</p>
	<ul style="list-style-type: none"> • Key off. • HEGO disconnected. • Measure resistance between KAPWR circuit and HEGO SIG circuit at the HEGO sensor connector. • Is resistance greater than 10,000 ohms? 	No	<p>REPLACE HEGO sensor. DRIVE vehicle 5 miles/55mph. RERUN Quick Test. (Refer to TESTING PROCEDURES/QUICK TEST AND DIAGNOSTIC AIDS/DETAILED QUICK TEST PROCEDURES/KEY ON ENGINE OFF SELF TEST for quick test procedures)</p>

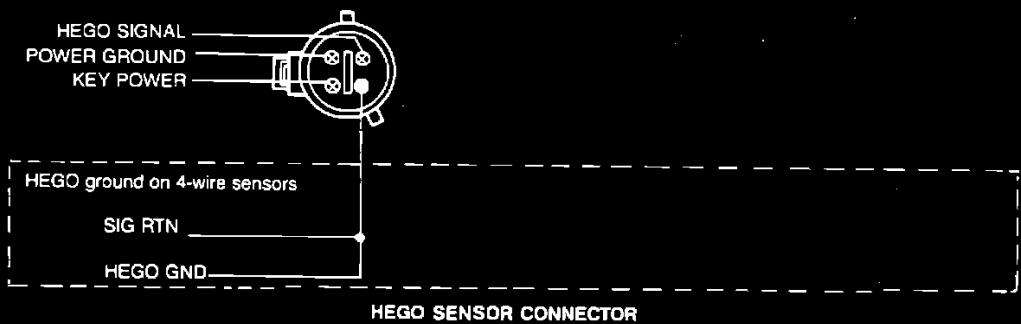

EEC-IV Pinpoint Test

TEST STEP		RESULT	ACTION TO TAKE
H27	ATTEMPT TO GENERATE CODE 41/172, 91/136, 176		
<ul style="list-style-type: none"> • Key off. • HEGO disconnected. • Jumper HEGO SIG circuit at the HEGO vehicle harness connector to battery negative post. • Rerun Engine Running Self-Test. (Refer to TESTING PROCEDURES/QUICK TEST AND DIAGNOSTIC AIDS/DETAILED QUICK TEST PROCEDURES/KEY ON ENGINE RUNNING SELF TEST for test procedures.) • Is Code 41/172, 91/136 present? 		Yes	REMOVE jumper. For Engines With MAP Sensor: GO to H28 . MAF sensor: GO to H30 .
		No	REMOVE jumper. RECONNECT HEGO sensor. DISCONNECT processor 60 pin connector. Inspect for damaged or pushed out pins, corrosion, loose wires, etc. SERVICE as necessary. If OK REPLACE processor. DRIVE vehicle 5miles/55mph. RERUN Quick Test. (Refer to TESTING PROCEDURES/QUICK TEST AND DIAGNOSTIC AIDS/DETAILED QUICK TEST PROCEDURES/KEY ON ENGINE OFF SELF TEST for quick test procedures)
H28	CHECK MAP SENSOR FOR VACUUM LEAK		
<p>NOTE: Due to the MAP sensor's large influence on fuel control, there is a possibility that MAP could be at fault without a Code 22/126. Therefore the next two Test Steps will verify proper vacuum to the MAP sensor and its ability to hold vacuum.</p> <ul style="list-style-type: none"> • Key off. • Disconnect vacuum line from MAP sensor. • Inspect hose for blockage (kinks or gel build up), damage from wear or aging. Service as necessary. • Plug vacuum hose at the MAP side. • Connect a vacuum pump to the MAP sensor and apply 18 in-Hg (60 kPa) vacuum to MAP sensor. • Does MAP sensor hold vacuum? 		Yes	RELEASE vacuum. GO to H29 .
		No	REPLACE MAP sensor. REMOVE vacuum pump. RECONNECT HEGO sensor. DRIVE vehicle 5miles/55mph. RERUN Quick Test. (Refer to TESTING PROCEDURES/QUICK TEST AND DIAGNOSTIC AIDS/DETAILED QUICK TEST PROCEDURES/KEY ON ENGINE OFF SELF TEST for quick test procedures)

EEC-IV Pinpoint Test

H29

*** Updated by TSB #9025B1

TEST STEP		RESULT	ACTION TO TAKE
H29	CHECK FOR LOSS OF VACUUM TO MAP SENSOR		
<ul style="list-style-type: none"> • Tee a vacuum gauge into the manifold vacuum line at the MAP sensor • Start the engine and let rpm stabilize. Note vacuum level. • Key off. • REMOVE vacuum gauge and tee and reconnect vacuum line to MAP sensor • Tee in vacuum gauge at a different source of intake manifold vacuum and restart the engine. Note vacuum level. • Does the vacuum level differ greater than 1 in-Hg? 		Yes	<p>▶ INSPECT engine vacuum integrity. SERVICE as necessary. REMOVE vacuum gauge and tee. RECONNECT HEGO sensor. DRIVE vehicle 5 miles/55 mph. RERUN Quick Test.</p> <p>(Refer to TESTING PROCEDURES/QUICK TEST AND DIAGNOSTIC AIDS/DETAILED QUICK TEST PROCEDURES/KEY ON ENGINE OFF SELF TEST for quick test procedures)</p>
		No	▶ GO to H30

EEC-IV Pinpoint Test

H30

*** Updated by TSB #9025B1

TEST STEP	RESULT	ACTION TO TAKE
<p>H30 HEGO SENSOR CHECK</p> <ul style="list-style-type: none"> • Key off. • HEGO sensor disconnected. <p>For 4 wire HEGO:</p> <ul style="list-style-type: none"> — Connect DVOM to HEGO SIGNAL and HEGO GND at the HEGO sensor connector. <p>For 3 wire HEGO:</p> <ul style="list-style-type: none"> — Connect DVOM to HEGO SIGNAL at the HEGO sensor connector and to battery negative post. <ul style="list-style-type: none"> • DVOM on 20 volt scale. • Create a vacuum leak to cause HEGO sensor to go lean. <p>For All Engines with MAF sensors:</p> <ul style="list-style-type: none"> — Disconnect any vacuum hose from the manifold vacuum tree. <p>For all other applications:</p> <ul style="list-style-type: none"> -Disconnect the PCV valve hose from the PCV valve. • Start engine and run at approximately 2000 rpm. • Does the DVOM Indicate less than 0.4 volts within 30 seconds? 	<p>Yes</p> <p>No</p>	<p>GO to H90 .</p> <p>REPLACE HEGO sensor. RECONNECT vacuum hoses. DRIVE vehicle 5 miles/55mph. RERUN Quick Test. (Refer to TESTING PROCEDURES/QUICK TEST AND DIAGNOSTIC AIDS/DETAILED QUICK TEST PROCEDURES/ KEY ON ENGINE OFF SELF TEST for quick test procedures)</p>

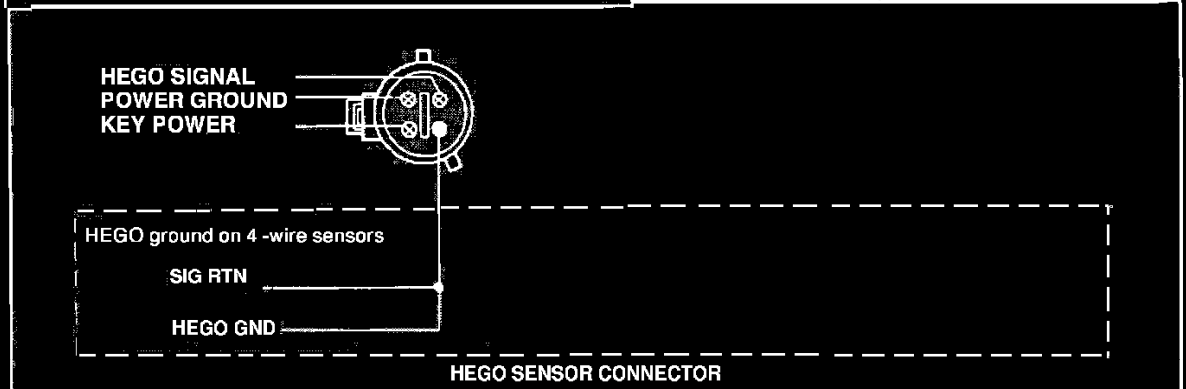

EEC-IV Pinpoint Test

H30 - H92

*** Updated by TSB #9025B1

TEST STEP		RESULT ▶	ACTION TO TAKE
H90	CHECK CONTINUOUS MONITOR MODE	Yes ▶	ISOLATE fault and SERVICE as necessary . REMOVE breakout box. CLEAR Continuous Memory Codes. (Refer to TESTING PROCEDURES/QUICK TEST AND DIAGNOSTIC AIDS/DETAILED QUICK TEST PROCEDURES/CONTINUOUS MEMORY CODES) RERUN Quick Test. (Refer to TESTING PROCEDURES/QUICK TEST AND DIAGNOSTIC AIDS/DETAILED QUICK TEST PROCEDURES/KEY ON ENGINE OFF SELF TEST for quick test procedures.)
<ul style="list-style-type: none"> • Key off. • Verify engine at operating temperature. • Start engine and run at 2,000 rpm for 2 minutes. • With engine rpm at idle enter Engine Running Continuous Monitor Mode. (Refer to Quick Test Appendix) • Observe VOM or STAR LED for indication of fault. • Wiggle, shake or bend a small section of the EEC-IV harness while working your way from the HEGO sensor to the processor. • Wiggle, shake or bend a small section of the EEC-IV harness while working your way from the HEGO GND to the processor. • Is a fault indicated? 		No ▶	REMAIN in Engine Running Continuous Monitor Mode GO to H91
H91	CONTINUOUS MONITOR TEST DRIVE CHECK	Yes ▶	ISOLATE fault and SERVICE as necessary. REMOVE breakout box. CLEAR Continuous Memory Codes. (Refer to TESTING PROCEDURES/QUICK TEST AND DIAGNOSTIC AIDS/DETAILED QUICK TEST PROCEDURES/CONTINUOUS MEMORY CODES.) RERUN Quick Test. (Refer to TESTING PROCEDURES/QUICK TEST AND DIAGNOSTIC AIDS/DETAILED QUICK TEST PROCEDURES/KEY ON ENGINE OFF SELF TEST for Quick Test procedures.)
<ul style="list-style-type: none"> • While still in Engine Running Continuous Monitor Mode. • Test drive vehicle at 55 mph with minimum road load for 5 miles. • Continue to drive on a rough road at 55 mph for 5 miles. • If possible drive vehicle through a pool of water on the road to shower the HEGO sensor and/or connector. • Is a fault indicated? 		No ▶	EXIT Engine Running Continuous Monitor Mode. GO to H92.
H92	CHECK HEGO SWITCHING	No ▶	REPLACE HEGO sensor. REMOVE breakout box. RECONNECT processor. RERUN Quick Test. (Refer to TESTING PROCEDURES/QUICK TEST AND DIAGNOSTIC AIDS/DETAILED QUICK TEST PROCEDURES/KEY ON ENGINE OFF SELF TEST for quick test procedures.)
<ul style="list-style-type: none"> • Key off. • Inspect EEC-IV wire harness for proper routing and insulation; burnt, chaffed, intermittently shorted or open. Service as necessary. • Disconnect processor 60 pin connector and inspect for damaged or pushed out pins, corrosion, loose wires, etc. Service as necessary. • Install breakout box and connect processor to breakout box. • Connect analog voltmeter to the suspect HEGO sensor test pin and HEGO GND at the breakout box. • Test drive vehicle at 55 mph with minimum roadload for 5 miles. • Observe vollmeter for HEGO switching from .3 to .9 volts within 3 seconds. • Did HEGO voltage switch? 		Yes ▶	Unable to duplicate or identify fault at this time. For further diagnosis using the EEC-IV monitor box, Refer to TESTING PROCEDURES/INTERMITTENT FAULT DIAGNOSIS.

EEC-IV Pinpoint Test

Note

You should enter this Pinpoint Test only when directed from Quick Test.

ADAPTIVE FUEL

The processor uses "adaptive fuel" logic primarily to compensate for normal variability in fuel system components. If, during normal vehicle operation, the fuel system appears "biased" rich or lean, adaptive fuel will make a corresponding "shift" in the fuel delivery calculations to compensate and remove the bias.

FUEL PRESSURE SPECIFICATION TABLE

	4.9L EFI	3.0L SHO SEFI	ALL OTHER APPLICATIONS
ENGINE RUNNING	45 — 60 PSI 310 — 415 kPa	28 — 33 PSI 193 — 227 kPa	30 — 45 PSI 210 — 310 kPa
KEY ON ENGINE OFF	50 — 60 PSI 345 — 415 kPa	30 — 45 PSI 210 — 310 kPa	35 — 45 PSI 240 — 310 kPa

MAP/BP SENSOR TESTER TABLE

Approximate Altitude (Ft.)	Voltage Output (+/- .04 Volts)
0	1.59
1000	1.56
2000	1.53
3000	1.50
4000	1.47
5000	1.44
6000	1.41
7000	1.39

NOTE: Measure several known good MAP/BP sensors on available vehicles. The measured voltage will be typical for your location on the day of testing.

EEC-IV Pinpoint Test

TEST STEP		RESULT	ACTION TO TAKE													
HA1	CONTINUOUS MEMORY SERVICE CODES 181, 183, 189, 192: IS VEHICLE A SEFI OR EFI?															
	<table border="1"> <thead> <tr> <th>Service Code</th> <th>Hego That Detected Problem</th> <th>Service Code Definition</th> </tr> </thead> <tbody> <tr> <td>183</td> <td>single/right/rear</td> <td rowspan="2">Adaptive fuel rich limit has been reached at idle</td> </tr> <tr> <td>192</td> <td>left/front</td> </tr> <tr> <td>181</td> <td>single/right/rear</td> <td rowspan="2">Adaptive fuel rich limit has been reached</td> </tr> <tr> <td>189</td> <td>left/front</td> </tr> </tbody> </table> <p>NOTES: — Verify that a pass code 111 is received in both Key On Engine Off and Engine Running Self-Test.</p> <p>— Whenever a repair is performed, clear Keep Alive Memory (KAM). Refer to Quick Test Appendix.</p> <p>— If no driveability symptom presently exists, be aware of other temporary conditions that may have set this code (ex: vehicle ran out of fuel, contaminated fuel).</p> <p>This Pinpoint Test will identify areas that could cause the HEGO sensor to detect excessive oxygen, resulting in adaptive fuel enriching the system to compensate. Excessive oxygen will be detected with lean conditions and certain rich conditions.</p> <p>For DUAL HEGO applications, if a related fuel code is present from both HEGO's then this could indicate that the problem is common to all cylinders. If a code is present from only one HEGO, this may help isolate a problem or be an early indication of a common problem.</p> <p>• Is vehicle a SEFI?</p>	Service Code	Hego That Detected Problem	Service Code Definition	183	single/right/rear	Adaptive fuel rich limit has been reached at idle	192	left/front	181	single/right/rear	Adaptive fuel rich limit has been reached	189	left/front	Yes	Go to HA2 .
Service Code	Hego That Detected Problem	Service Code Definition														
183	single/right/rear	Adaptive fuel rich limit has been reached at idle														
192	left/front															
181	single/right/rear	Adaptive fuel rich limit has been reached														
189	left/front															
		No	GO to HA3 .													

EEC-IV Pinpoint Test

TEST STEP		RESULT	ACTION TO TAKE
HA2	RUN CYLINDER BALANCE TEST		
<ul style="list-style-type: none"> • Run the Engine Running Self-Test. (Refer to TESTING PROCEDURES/QUICK TEST AND DIAGNOSTIC AIDS/DETAILED QUICK TEST PROCEDURES/KEY ON ENGINE RUNNING SELF TEST and ENGINE RUNNING SELF TEST for test procedures). • After the last repeated code, wait 5-10 seconds. • "Goose" throttle lightly (not wide-open). • Cylinder Balance Test will be performed. Time of test is approximately 2-3 minutes. For more information on Cylinder Balance Test, refer to 		Yes	GO to HA3 .
<ul style="list-style-type: none"> • Is code 90 present? 		No	GO to HA35 .
HA3	CHECK FOR VACUUM/AIR INDUCTION LEAKS		
<ul style="list-style-type: none"> • Check vacuum system for leaks, etc. • Check air induction system for leaks, etc. • Are vacuum and air induction systems OK? 		Yes	GO to HA4
		No	SERVICE as necessary. CLEAR KAM. RERUN Quick Test. (Refer to TESTING PROCEDURES/QUICK TEST AND DIAGNOSTIC AIDS/DETAILED QUICK TEST PROCEDURES/CONTINUOUS MEMORY CODES for code clearing procedures.) (Refer to TESTING PROCEDURES/QUICK TEST AND DIAGNOSTIC AIDS/DETAILED QUICK TEST PROCEDURES/KEY ON ENGINE OFF SELF TEST for quick test procedures.)
HA4	CHECK FOR LOW FUEL PRESSURE		
<div style="border: 1px solid black; padding: 2px; width: fit-content; margin-bottom: 10px;">WARNING</div> <p>THE FUEL SYSTEM WILL REMAIN PRESSURIZED WHEN THE ENGINE IS NOT RUNNING. TO PREVENT INJURY OR FIRE USE CAUTION WHEN WORKING ON THE FUEL SYSTEM.</p> <ul style="list-style-type: none"> • Key off. • Install fuel pressure gauge. • Cycle key from OFF to RUN a couple times. • Note Key On Engine Off fuel pressure. • Start engine. Note Engine Running fuel pressure. • Refer to the Fuel Pressure Specification Table on this Pinpoint Test's cover page. • Is fuel pressure within specification? 		Yes	GO to HA5 .
		No	CHECK the fuel pressure regulator, fuel supply lines, fuel filter, fuel pump , etc. Refer to FUEL SYSTEMS. After servicing, CLEAR KAM and RERUN Quick Test. (Refer to TESTING PROCEDURES/QUICK TEST AND DIAGNOSTIC AIDS/DETAILED QUICK TEST PROCEDURES/KEY ON ENGINE OFF SELF TEST for quick test procedures.)

EEC-IV Pinpoint Test

TEST STEP		RESULT	ACTION TO TAKE
HA5	CHECK SYSTEMS ABILITY TO HOLD FUEL PRESSURE		
<ul style="list-style-type: none"> Fuel pressure gauge installed. Cycle key from OFF to ON a couple times to pressurize fuel system. Do not start engine. Does fuel pressure remain at specification for 60 seconds? 		Yes	<p>For vehicles with MAP/BP sensors: GO to HA6 .</p> <p>For all others: GO to HA7 .</p>
		No	<p>Visually CHECK for fuel leaking at fuel injector O-rings, fuel pressure regulator, fuel rail, etc. SERVICE as necessary. CLEAR KAM. RERUN Quick Test.(Refer to TESTING PROCEDURES/QUICK TEST AND DIAGNOSTIC AIDS/DETAILED QUICK TEST PROCEDURES/CONTINUOUS MEMORY CODES for code clearing procedures.)</p>
HA6	CHECK MAP/BP FREQUENCY		
<ul style="list-style-type: none"> Key off. Connect MAP/BP tester. Key on. Refer to MAP/BP Frequency Charts on this Pinpoint Test's cover page (also PPT DF's cover pages) to check MAP/BP frequency. It may be necessary to measure several known good MAP/BP sensors on available vehicles to determine your areas typical reading for that day. Is MAP/BP frequency within specification? 		Yes	GO to HA7 .
		No	<p>CHECK wiring to MAP/BP sensor for corrosion, high resistance, etc. If OK, REPLACE MAP/BP sensor. CLEAR KAM. RERUN Quick Test. (Refer to TESTING PROCEDURES/QUICK TEST AND DIAGNOSTIC AIDS/DETAILED QUICK TEST PROCEDURES/CONTINUOUS MEMORY CODES for code clearing procedures).</p>
HA7	CHECK FOR PROPER BATTERY VOLTAGE TO FUEL INJECTORS		
<ul style="list-style-type: none"> Key on, engine off. Measure battery voltage at the battery posts. Note voltage. Disconnect any fuel injector harness connector. Measure voltage between the VPWR circuit at the fuel injector vehicle harness connector and the battery negative post. Note voltage. Are both voltage readings within 1.0 volt of each other? 		Yes	<p>For 4.9L E40D: GO to HA9 .</p> <p>For all others: GO to HA8 .</p>
		No	<p>The fuel injectors are not getting proper battery voltage. ISOLATE problem and SERVICE as necessary CLEAR KAM. RERUN Quick Test. (Refer to TESTING PROCEDURES/QUICK TEST AND DIAGNOSTIC AIDS/DETAILED QUICK TEST PROCEDURES/CONTINUOUS MEMORY CODES for code clearing procedures).</p>

EEC-IV Pinpoint Test

TEST STEP		RESULT	ACTION TO TAKE
HA8	VERIFY THAT CANP SOLENOID IS NOT STUCK CLOSED	Yes	RECONNECT vacuum hose to CANP. For vehicles with a thermactor system: GO to HA9 . For all others: GO to HA25 .
	<ul style="list-style-type: none"> • Enter Output State Check (Refer to TESTING PROCEDURES/ QUICK TEST AND DIAGNOSTIC AIDS/OUTPUT STATE CHECK) • Disconnect hose to manifold vacuum at CANP solenoid. Check for blockage. Service as necessary. • With outputs OFF, apply 16 in-Hg vacuum to manifold vacuum side of CANP. • Depress throttle to cycle outputs ON. • Does vacuum release? 	No	REPEAT this test step to verify results. If vacuum again will not release, CHECK vacuum hose to cannister and cannister for blockage. SERVICE as necessary. If OK, REPLACE CANP solenoid. CLEAR KAM. RERUN Quick Test. (Refer to TESTING PROCEDURES/QUICK TEST AND DIAGNOSTIC AIDS/DETAILED QUICK TEST PROCEDURES/ CONTINUOUS MEMORY CODES for code clearing procedures). (Refer to TESTING PROCEDURES/QUICK TEST AND DIAGNOSTIC AIDS /DETAILED QUICK TEST PROCEDURES/KEY ON ENGINE OFF SELF TEST for quick test procedures)
HA9	CHECK THERMACTOR SYSTEM FOR UPSTREAM AIR LEAK	Yes	GO to HA25 .
	<ul style="list-style-type: none"> • Perform the functional diagnosis of the Thermactor Air Control/Vacuum Control Valve(s). Refer to EMISSION CONTROLS. • Does the Air Control Valve pass testing? 	No	REPAIR as instructed in EMISSION CONTROLS. CLEAR KAM. RERUN Quick Test. (Refer to TESTING PROCEDURES/QUICK TEST AND DIAGNOSTIC AIDS/DETAILED QUICK TEST PROCEDURES/ CONTINUOUS MEMORY CODES for code clearing procedures). (Refer to TESTING PROCEDURES/QUICK TEST AND DIAGNOSTIC AIDS /DETAILED QUICK TEST PROCEDURES/KEY ON ENGINE OFF SELF TEST for quick test procedures)

EEC-IV Pinpoint Test

TEST STEP		RESULT	ACTION TO TAKE													
HA15	CONTINUOUS MEMORY SERVICE CODES 179, 182, 188, 191: IS VEHICLE SEFI OR EFI?															
	<table border="1"> <thead> <tr> <th>Service Code</th> <th>Hego That Detected Problem</th> <th>Service Code Definition</th> </tr> </thead> <tbody> <tr> <td>182</td> <td>single/right/rear</td> <td rowspan="2">Adaptive fuel lean limit has been reached at idle</td> </tr> <tr> <td>191</td> <td>left/front</td> </tr> <tr> <td>179</td> <td>single/right/rear</td> <td rowspan="2">Adaptive fuel lean limit has been reached</td> </tr> <tr> <td>188</td> <td>left/front</td> </tr> </tbody> </table> <p>NOTES: — Verify that a pass code 111 is received in both Key On Engine Off and Engine Running Self-Test. — Whenever a repair is performed, clear Keep Alive Memory (KAM). (Refer to TESTING PROCEDURES/QUICK TEST AND DIAGNOSTIC AIDS/DETAILED QUICK TEST PROCEDURES/CONTINUOUS MEMORY CODES for code clearing procedures.)</p> <p>This Pinpoint Test will identify areas that could cause the engine to run rich, resulting in adaptive fuel leaning the system to compensate. For DUAL HEGO applications, if a related fuel code is present from both HEGO's then this could indicate that the problem is common to all cylinders. If a code is present from only one side, this may help isolate a problem or be an early indication of a common problem.</p> <ul style="list-style-type: none"> • Is vehicle a SEFI? 	Service Code	Hego That Detected Problem	Service Code Definition	182	single/right/rear	Adaptive fuel lean limit has been reached at idle	191	left/front	179	single/right/rear	Adaptive fuel lean limit has been reached	188	left/front	<p>Yes</p> <p>No</p>	<p>GO to HA16 .</p> <p>GO to HA17 .</p>
Service Code	Hego That Detected Problem	Service Code Definition														
182	single/right/rear	Adaptive fuel lean limit has been reached at idle														
191	left/front															
179	single/right/rear	Adaptive fuel lean limit has been reached														
188	left/front															
HA16	RUN CYLINDER BALANCE TEST															
	<ul style="list-style-type: none"> • Run the Engine Running Self-Test. • After the last repeated code, wait 5-10 seconds. • "Goose" the throttle lightly (not wide open). • Cylinder Balance Test will be performed. Time of test is approximately 2-3 minutes. For more information on Cylinder Balance Test refer to TESTING PROCEDURES/QUICK TEST AND DIAGNOSTIC AIDS/DETAILED QUICK TEST PROCEDURES/KEY ON ENGINE RUNNING SELF TEST. <ul style="list-style-type: none"> • Is code 90 present? 	<p>Yes</p> <p>No</p>	<p>GO to HA17 .</p> <p>GO to HA35 .</p>													

EEC-IV Pinpoint Test

TEST STEP		RESULT	ACTION TO TAKE
HA17	CHECK FOR EXCESSIVE FUEL PRESSURE		
<div style="border: 1px solid black; padding: 2px; width: fit-content; margin-bottom: 10px;">WARNING</div> <p>THE FUEL SYSTEM WILL REMAIN PRESSURIZED WHEN THE ENGINE IS NOT RUNNING. TO PREVENT INJURY OR FIRE USE CAUTION WHEN WORKING ON THE FUEL SYSTEM.</p> <ul style="list-style-type: none"> • Key off. • Verify manifold vacuum is connected to the fuel pressure regulator, if applicable. • Install fuel pressure gauge. • Cycle key from OFF to ON a couple times. • Note Key On Engine Off fuel pressure. • Start engine. Note Engine Running fuel pressure. • Refer to the Fuel Pressure Specification Table on this Pinpoint Test's cover page. • Is fuel pressure within specification? 		<p>Yes ▶</p> <p>No ▶</p>	<p>GO to HA18 .</p> <p>CHECK condition of fuel pressure regulator vacuum hose, fuel return line, fuel pressure regulator, etc. REFER to FUEL SYSTEMS SERVICE as necessary. CLEAR KAM. RERUN Quick Test. (Refer to TESTING PROCEDURES/QUICK TEST AND DIAGNOSTIC AIDS/ DETAILED QUICK TEST PROCEDURES/CONTINUOUS MEMOSRY CODES for code clearing procedures.) (Refer to TESTING PROCEDURES/QUICK TEST AND DIAGNOSTIC AIDS /DETAILED QUICK TEST PROCEDURES/KEY ON ENGINE OFF SELF TEST for quick test procedures)</p>
HA18	CHECK SYSTEMS ABILITY TO HOLD FUEL PRESSURE		
<ul style="list-style-type: none"> • Fuel pressure gauge installed. • Cycle key from OFF to ON a couple times. Do not start engine. • Does fuel pressure remain at specification for 60 seconds? 		<p>Yes ▶</p> <p>No ▶</p>	<p>For vehicles with a MAP/BP sensors: GO to HA19 .</p> <p>All others: GO to HA20 .</p> <p>Check for injectors leaking fuel into cylinder, etc. SERVICE as necessary. CLEAR KAM. RERUN Quick Test. (Refer to TESTING PROCEDURES/QUICK TEST AND DIAGNOSTIC AIDS /DETAILED QUICK TEST PROCEDURES/KEY ON ENGINE OFF SELF TEST for quick test procedures)</p>

EEC-IV Pinpoint Test

TEST STEP		RESULT	ACTION TO TAKE
HA19	CHECK MAP/BP FREQUENCY	Yes	GO to HA20 .
<ul style="list-style-type: none"> • Key off. • Connect MAP/BP tester. • Key on, engine off. • Refer to MAP/BP Frequency Charts on this pinpoint test's cover page (also Pinpoint Test DF's cover pages) to check MAP/BP frequency. It may be necessary to measure several known good MAP/BP sensors on available vehicles to determine your areas typical reading for that day. • Is MAP/BP frequency within specification? 		No	<p>CHECK wiring to MAP /BP sensor for corrosion, high resistance, etc.If OK, REPLACE MAP/BP sensor. CLEAR KAM. RERUN Quick Test.</p> <p>(Refer to TESTING PROCEDURES/ QUICK TEST AND DIAGNOSTIC AIDS/ DETAILED QUICK TEST PROCEDURES/ CONTINUOUS MEMORY CODES for code clearing procedures.)</p> <p>(Refer to TESTING PROCEDURES/ QUICK TEST AND DIAGNOSTIC AIDS/ DETAILED QUICK TEST PROCEDURES/ KEY ON ENGINE OFF SELF TEST for quick test procedures.)</p>
HA20	CHECK THROTTLE BODY AND AIR INDUCTION SYSTEM	YES	For 4.9L E40D: GO to HA2! For all others:GO to HA2!
<ul style="list-style-type: none"> • Check throttle body and air induction system for contamination, obstructions, etc. • Are checks OK? 		NO	<p>SERVICE as necessary (for throttle body cleaning refer to COMPONENT REPLACEMENT AND REPAIR PROCEDURES/IDLE SPEED CONTROL BYPASS AIR [ISC-BPA] VALVE) CLEAR KAM. RERUN Quick Test.</p> <p>(Refer to TESTING PROCEDURES/ QUICK TEST AND DIAGNOSTIC AIDS/ DETAILED QUICK TEST PROCEDURES/ CONTINUOUS MEMORY CODES for code clearing procedures.)</p> <p>(Refer to TESTING PROCEDURES/ QUICK TEST AND DIAGNOSTIC AIDS/ DETAILED QUICK TEST PROCEDURES/ KEY ON ENGINE OFF SELF TEST for quick test procedures.)</p>
HA21	VERIFY THAT CANP WILL HOLD VACUUM	Yes	RECONNECT vacuum hose. GO to HA25 .
<ul style="list-style-type: none"> • Key off. • Disconnect vacuum hose to manifold vacuum at CANP solenoid. • Apply 16 in-Hg of vacuum to manifold vacuum side of CANP solenoid. • Does solenoid hold vacuum for 20 seconds? 		No	<p>REPLACE CANP solenoid. CLEAR KAM. RERUN Quick Test.</p> <p>(Refer to TESTING PROCEDURES/ QUICK TEST AND DIAGNOSTIC AIDS/ DETAILED QUICK TEST PROCEDURES/ CONTINUOUS MEMORY CODES for code clearing procedures.)</p> <p>(Refer to TESTING PROCEDURES/ QUICK TEST AND DIAGNOSTIC AIDS/ DETAILED QUICK TEST PROCEDURES/ KEY ON ENGINE OFF SELF TEST for quick test procedures.)</p>
HA25	CHECK PCV VALVE	Yes	GO to HA26 .
<ul style="list-style-type: none"> • Key off. • Remove PCV valve and shake. • Does PCV valve rattle freely when shaken? 		No	<p>REPLACE PCV valve. CLEAR KAM. RERUN Quick Test.</p> <p>(Refer to TESTING PROCEDURES/ QUICK TEST AND DIAGNOSTIC AIDS/ DETAILED QUICK TEST PROCEDURES/ CONTINUOUS MEMORY CODES for code clearing procedures.)</p> <p>(Refer to TESTING PROCEDURES/ QUICK TEST AND DIAGNOSTIC AIDS/ DETAILED QUICK TEST PROCEDURES/ KEY ON ENGINE OFF SELF TEST for quick test procedures.)</p>

EEC-IV Pinpoint Test

TEST STEP		RESULT	ACTION TO TAKE
HA26	CHECK HEGO HEATER CIRCUIT	Yes	GO to HA27 .
	<ul style="list-style-type: none"> • Key off. • Disconnect HEGO sensor(s). • Measure resistance between KEY POWER circuit and PWR GND at the HEGO sensor connector(s). Resistance should be between 2.0 ohms (room temperature) and 35.0 ohms (hot). • Key on, engine off. • Measure voltage between KEY POWER circuit and PWR GND circuit at the HEGO sensor vehicle harness connector(s). Voltage should be greater than 10.5 volts. • Does the HEGO heater circuit(s) check OK? 	No	ISOLATE problem and SERVICE as necessary. CLEAR KAM RERUN Quick Test. (Refer to TESTING PROCEDURES/ QUICK TEST AND DIAGNOSTIC AIDS/ DETAILED QUICK TEST PROCEDURES/ CONTINUOUS MEMORY CODES for code clearing procedures.) (Refer to TESTING PROCEDURES/ QUICK TEST AND DIAGNOSTIC AIDS/ DETAILED QUICK TEST PROCEDURES/ KEY ON ENGINE OFF SELF TEST for quick test procedures.)
HA27	INSPECT HEGO SENSOR FOR CONTAMINATION	Yes	For vehicles with an EGR system: GO to HA28 . For all others: GO to HA30 .
	<ul style="list-style-type: none"> • Remove HEGO sensor(s) from the exhaust manifold • Visually inspect for contamination, etc. • Does the HEGO sensor(s) appear OK? 	No	REPLACE HEGO sensor. CLEAR KAM. RERUN Quick Test. (Refer to TESTING PROCEDURES/ QUICK TEST AND DIAGNOSTIC AIDS/ DETAILED QUICK TEST PROCEDURES/ CONTINUOUS MEMORY CODES for code clearing procedures.) (Refer to TESTING PROCEDURES/ QUICK TEST AND DIAGNOSTIC AIDS/ DETAILED QUICK TEST PROCEDURES/ KEY ON ENGINE OFF SELF TEST for quick test procedures.)
HA28	VERIFY EXCESSIVE VACUUM IS NOT AT EGR VALVE DURING IDLE	Yes	GO to HA29 .
	<ul style="list-style-type: none"> • Disconnect vacuum line at EGR valve. • Connect vacuum gauge to EGR vacuum line. • Start engine and let idle. • Is vacuum reading less than 2.5 in Hg? 	No	CHECK EVR solenoid filter for obstructions SERVICE as necessary. If OK, REPLACE EVR solenoid. RECONNECT vacuum line to EGR valve . CLEAR KAM. RERUN Quick Test. (Refer to TESTING PROCEDURES/ QUICK TEST AND DIAGNOSTIC AIDS/ DETAILED QUICK TEST PROCEDURES/ CONTINUOUS MEMORY CODES for code clearing procedures.) (Refer to TESTING PROCEDURES/ QUICK TEST AND DIAGNOSTIC AIDS/ DETAILED QUICK TEST PROCEDURES/ KEY ON ENGINE OFF SELF TEST for quick test procedures.)

EEC-IV Pinpoint Test

TEST STEP		RESULT	ACTION TO TAKE
HA29	VERIFY EGR VALVE IS FULLY SEATED	Yes	▶ RECONNECT vacuum line to EGR valve. GO TO HA30.
	<ul style="list-style-type: none"> Inspect EGR valve to ensure proper seating. Is EGR valve fully seated (closed)? 	No	▶ GO to EMISSION CONTROLS for EGR valve diagnosis. After servicing, CLEAR KAM and RERUN Quick Test. (Refer to TESTING PROCEDURES/QUICK TEST AND DIAGNOSTIC AIDS/DETAILED QUICK TEST PROCEDURES/CONTINUOUS MEMORY CODES for code clearing procedures.) (Refer to TESTING PROCEDURES/QUICK TEST AND DIAGNOSTIC AIDS/DETAILED QUICK TEST PROCEDURES/KEY ON ENGINE OFF SELF TEST for quick test procedures.)
HA30	CHECK COOLING SYSTEM	Yes	▶ GO to HA35 .
	<ul style="list-style-type: none"> Verify that the cooling system is operating properly. Refer to ENGINE MECHANICAL Is the cooling system operating properly? 	No	▶ Service as necessary. CLEAR KAM. RERUN Quick Test. (Refer to TESTING PROCEDURES/QUICK TEST AND DIAGNOSTIC AIDS/DETAILED QUICK TEST PROCEDURES/CONTINUOUS MEMORY CODES for code clearing procedures.) (Refer to TESTING PROCEDURES/QUICK TEST AND DIAGNOSTIC AIDS/DETAILED QUICK TEST PROCEDURES/KEY ON ENGINE OFF SELF TEST for quick test procedures.)
HA35	CHECK IGNITION SYSTEM	Yes	▶ GO to HA36 .
	<ul style="list-style-type: none"> Verify ignition system is operating properly. Scope engine for spark plug, coil, secondary wires, distributor cap, rotor, timing etc. Refer to IGNITION SYSTEMS Is the ignition system operating properly? 	No	▶ SERVICE as necessary, REFER to IGNITION SYSTEMS. CLEAR KAM. RERUN Quick Test. (Refer to TESTING PROCEDURES/QUICK TEST AND DIAGNOSTIC AIDS/DETAILED QUICK TEST PROCEDURES/CONTINUOUS MEMORY CODES for code clearing procedures.) (Refer to TESTING PROCEDURES/QUICK TEST AND DIAGNOSTIC AIDS/DETAILED QUICK TEST PROCEDURES/KEY ON ENGINE OFF SELF TEST for quick test procedures.)

EEC-IV Pinpoint Test

TEST STEP	RESULT	ACTION TO TAKE
<p>HA36 FLOW CHECK INJECTORS</p> <ul style="list-style-type: none"> • Flow check injectors. Refer to FUEL SYSTEMS. • Is flow within specification? 	<p>Yes</p> <p>No</p>	<p>GO to HA37 .</p> <p>Refer to FUEL SYSTEMS for instructions to service out of specification injectors. After servicing, CLEAR KAM and RERUN Quick Test.</p> <p>(Refer to TESTING PROCEDURES/ QUICK TEST AND DIAGNOSTIC AIDS/ DETAILED QUICK TEST PROCEDURES/ CONTINUOUS MEMORY CODES for code clearing procedures.)</p> <p>(Refer to TESTING PROCEDURES/ QUICK TEST AND DIAGNOSTIC AIDS/ DETAILED QUICK TEST PROCEDURES/ KEY ON ENGINE OFF SELF TEST for quick test procedures.)</p>
<p>A37 CHECK CYLINDER COMPRESSION</p> <ul style="list-style-type: none"> • Check cylinder compression. Refer to the ENGINE MECHANICAL. • Are cylinder compression readings within specification? 	<p>Yes</p> <p>No</p>	<p>For further diagnosis using the EEC-IV Monitor Box, Refer to TESTING PROCEDURES/INTERMITTENT FAULT DIAGNOSIS.</p> <p>IF an EEC-IV Monitor Box is not available, Go to HA40.</p> <p>REFER to the ENGINE MECHANICAL for servicing instruction. After servicing, CLEAR KAM and RERUN Quick Test.</p> <p>(Refer to TESTING PROCEDURES/ QUICK TEST AND DIAGNOSTIC AIDS/ DETAILED QUICK TEST PROCEDURES/ CONTINUOUS MEMORY CODES for code clearing procedures.)</p> <p>(Refer to TESTING PROCEDURES/ QUICK TEST AND DIAGNOSTIC AIDS/ DETAILED QUICK TEST PROCEDURES/ KEY ON ENGINE OFF SELF TEST for quick test procedures.)</p>

EEC-IV Pinpoint Test

HA40 ROAD TEST

The purpose of the road test is to identify an area of concern by monitoring certain controlled parameters while trying to re-create a driveability or MIL light symptom.

NOTE

A basic working knowledge of the EEC-IV system is critical to effectively analyze road test data.

WARNING

THIS ROAD TEST IS A SUGGESTED BUT OPTIONAL PROCEDURE. ALL APPLICABLE SAFETY PROCEDURES AND TRAFFIC LAWS MUST BE FOLLOWED. IN ORDER FOR A ROAD TEST TO BE PERFORMED IT IS REQUIRED THAT ANOTHER PERSON ACCOMPANY THE DRIVER. THE ACCOMPANYING PERSON CAN MAKE MEASUREMENTS, OBSERVE CHANGES AND RECORD NOTES. IF FOR SOME REASON THIS TEST IS NOT PERFORMED, RETURN TO SECTION 2 FOR OTHER POSSIBLE CAUSES.

PREPARE VEHICLE FOR A ROAD TEST

- Fuel pressure gauge and MAP/BP tester installed.
- Disconnect processor 60 pin connector. Inspect for damaged or pushed out pins, corrosion, loose wires, etc. Service as necessary.
- Install breakout box and connect processor to breakout box.
- Tee in a vacuum gauge to manifold vacuum.
- Other materials needed; DVOM, pencil, paper, appropriate schematic/pin usage sheet (from Section 3 or 4).

PRELIMINARY POWER/GROUND CHECKS

- With the key ON and a DVOM referenced to the battery negative post, check the following signals for correct values.
POWERS: KAPWR >10.5V (pin 1); VPWR >10.5V (pins 37/57); VREF 5±1V (pin 26)
GROUNDS (all = 0±.5V): PWR GND (pins 40/60); SIG RTN (pin 46); IGN GND (pin 16)
OPTIONAL GROUNDS: HEGO GND (pin 49); CSE GND (pin 20); MAF RTN (pin 9 or 15)

OBTAINING OTHER NEEDED INFORMATION AND MATERIALS BEFORE THE ROAD TEST

- Refer to the Symptom Charts in TESTING PROCEDURES/INTERMITTENT FAULT DIAGNOSIS looking at the chart(s) that closest resembles the vehicles' driveability or MIL light symptom. Before the road test perform the Visual/Mechanical Checks that are listed. Next, list the EEC-IV sensors and actuators in the order given. These are the main signals that will be monitored.

HA40 ROAD TEST

- Refer to the proper Diagnostic Reference Value Sheet in TESTING PROCEDURES/INTERMITTENT FAULT DIAGNOSIS/DIAGNOSTIC REFERENCE VALUES. these charts were designed for use with the EEC-IV Monitor Box, most of the values can be read using the breakout box and a DVOM (with the DVOM reference to ground all values in DCV units can be used; other values may also be helpful, ex. MAP Hz using the MAP/BP tester). Also refer to TESTING PROCEDURES/INTERMITTENT FAULT DIAGNOSIS/GRAPHS AND CHARTS.

ROAD TEST

- Drive the vehicle to create the conditions so that the symptom will occur. If the DRIVEABILITY WORKSHEET from INFO TYPE/TECHNICAL MANAGEMENT SUPPORT has been completed, this information will help when trying to recreate the symptom.
- When the symptom occurs, the accompanying passenger should observe changes in listed EEC-IV signals. Information about the symptom, operating condition value of the EEC-IV signal or other notes should be recorded onto paper.
- If you are unable to duplicate the symptom, it may still be helpful to verify that the EEC-IV values are in the expected range.

ANALYZING THE DATA

- Once the road test is completed, the results need to be analyzed to locate and repair the exact fault which caused the symptom.
- If no problem is identified, return to DIAGNOSTIC ROUTINES for other possible causes of the symptom.

EEC-IV Pinpoint Test

Pinpoint Test Schematic

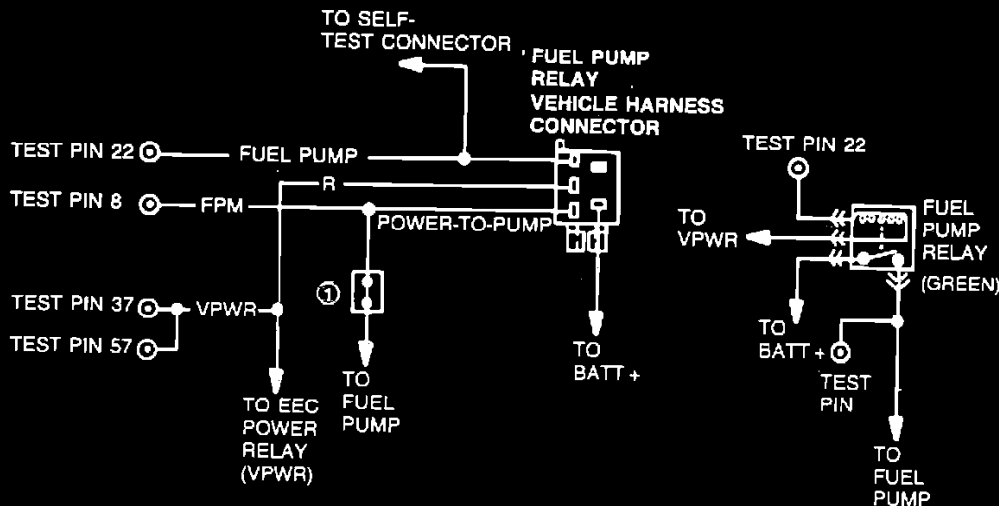

① INERTIA SWITCH LOCATION

TEST PIN 8
POWER-TO-PUMP Circuit

Application	Wire Color
F-Series Bronco E-Series	DG/Y

Test Pin 22 FP

Application	Wire Color
F-Series Bronco	LB/O
All Others	T/LG

EEC-IV Pinpoint Test

Note

You should enter this Pinpoint Test only when you have been directed here from Quick Test or Pinpoint Test A.

Remember

This Pinpoint Test is intended to diagnose only the following:

- Fuel Pump Relay (9345 or 14512)
- Inertia Switch (9341)
- Harness circuits: BATT (+), VPWR, FP, GND and Power-To-Pump(s)
- Processor Assembly (12A650)

EEC-IV Pinpoint Test

TEST STEP		RESULT	ACTION TO TAKE
J1	NO FUEL PUMP PRESSURE: CHECK FOR FUEL PUMP ELECTRICAL OPERATION		
	<ul style="list-style-type: none"> To check if fuel pump runs, turn key from Off to Run position, repeat several times. (Do not turn to start position.) Does fuel pump run briefly each time the key is turned to RUN position? 	Yes	GO to FUEL SYSTEMS.
		No	GO to J2.
J2	CHECK FOR VPWR TO PROCESSOR		
	<ul style="list-style-type: none"> Key off. Breakout box installed, processor connected. Key on, engine off. Measure voltage between Test Pin 37 and Test Pin 40 at the breakout box and between Test Pin 57 and Test Pin 60 at the breakout box. Are both voltages greater than 10.5 volts? 	Yes	GO to J3.
		No	GO to PINPOINT TEST B, STEP B1.
J3	CHECK FOR VOLTAGE TO POWER-TO- PUMP(S) CIRCUIT		
	<ul style="list-style-type: none"> Key on, engine off. Breakout box installed, processor connected. Measure voltage between chassis ground and Power-To-Pump circuit at fuel pump relay while cranking engine. Is voltage greater than 8.0 volts during crank? 	Yes	GO to FUEL SYSTEMS for open in Power-To-Pump circuit, fuel pump GND, open in pump, etc.
		No	GO to J4.

EEC-IV Pinpoint Test

TEST STEP		RESULT	ACTION TO TAKE
J4	CHECK FOR BATT+ TO FUEL PUMP RELAY		
<ul style="list-style-type: none"> • Key on, engine off. • Breakout box installed, processor connected. • Measure voltage between chassis ground and BATT(+) at the fuel pump relay. • Is voltage greater than 10.5 volts? 		Yes	GO to J5 .
		No	VERIFY integrity of Fuse/Fuse Link for BATT(+) supply to fuel pump relay. If OK, SERVICE open in BATT (+) between fuel pump relay and battery positive post(for relay block applications, between fuel pump relay and EEC power relay.) REMOVE breakout box.RECONNECT processor. RERUN Quick Test. (Refer to TESTING PROCEDURES/QUICK TEST AND DIAGNOSTIC AIDS/ DETAILED QUICK TEST PROCEDURES/KEY ON ENGINE OFF SELF TEST for quick test procedures).
J5	CHECK FOR VOLTAGE AT POWER-TO-PUMP(S) CIRCUIT		
<ul style="list-style-type: none"> • Key off. • Breakout box installed. • Disconnect processor. • Connect jumper wire from Test Pin 22 to Test Pin 40 or 60 at the breakout box. • Key on, engine off. • Measure voltage between chassis ground and Power-To-Pump circuit at fuel pump relay. • Is voltage greater than 10.5 volts? 		Yes	REPLACE processor. REMOVE breakout box. RERUN Quick Test. (Refer to TESTING PROCEDURES/QUICK TEST AND DIAGNOSTIC AIDS/ DETAILED QUICK TEST PROCEDURES/KEY ON ENGINE OFF SELF TEST for quick test procedures).
		No	REPLACE fuel pump relay.REMOVE breakout box. RECONNECT processor. RERUN Quick Test. (Refer to TESTING PROCEDURES/QUICK TEST AND DIAGNOSTIC AIDS/ DETAILED QUICK TEST PROCEDURES/KEY ON ENGINE OFF SELF TEST for quick test procedures).

EEC-IV Pinpoint Test

TEST STEP		RESULT	ACTION TO TAKE
J7	SERVICE CODE 87/556: CHECK FOR VPWR TO FUEL PUMP RELAY		
<p>Service Code 87/556 indicates a fuel pump primary circuit failure.</p> <p>Possible causes are:</p> <ul style="list-style-type: none"> — Inertia switch not reset or electrically open (if in primary circuit). — Open or shorted circuit. — Faulty fuel pump relay. — Faulty processor. <ul style="list-style-type: none"> • Disconnect fuel pump relay. • Key on, engine off. • Measure voltage between chassis ground and VPWR circuit at the fuel pump relay vehicle harness connector. <ul style="list-style-type: none"> • Is voltage greater than 10.5 volts? 		<p>Yes</p> <p>No</p>	<p>GO to J6.</p> <p>VERIFY integrity of inertia switch. If OK, SERVICE open in VPWR circuit between the EEC power relay and the fuel pump relay. RECONNECT fuel pump relay. RERUN Quick Test. (Refer to TESTING PROCEDURES/QUICK TEST AND DIAGNOSTIC AIDS/ DETAILED QUICK TEST PROCEDURES/KEY ON ENGINE OFF SELF TEST for quick test procedures).</p>

EEC-IV Pinpoint Test

TEST STEP		RESULT	ACTION TO TAKE
J8	CHECK FUEL PUMP RELAY		
<ul style="list-style-type: none"> • Key off. • Fuel pump relay disconnected. • DVOM on 200 ohm scale. • Check fuel pump relay coil resistance: <ul style="list-style-type: none"> — Measure resistance between VPWR (Ignition Start/Run for Tempo/Topaz) pin and Fuel Pump circuit pin at the fuel pump relay. — Resistance should be between 40 and 85 ohms. • DVOM on 10,000 ohm scale. • Check fuel pump relay for internal shorts. <ul style="list-style-type: none"> — Measure resistance between the Fuel Pump circuit pin and both the Power-to-Pump and BATT(+) pins at the fuel pump relay. — Both resistances should be greater than 10,000 ohms. • Are all resistance checks OK? 		Yes No	GO to J9. REPLACE fuel pump relay. RERUN Quick Test. (Refer to TESTING PROCEDURES/QUICK TEST AND DIAGNOSTIC AIDS/DETAILED QUICK TEST PROCEDURES/KEY ON ENGINE OFF SELF TEST for quick test procedures).

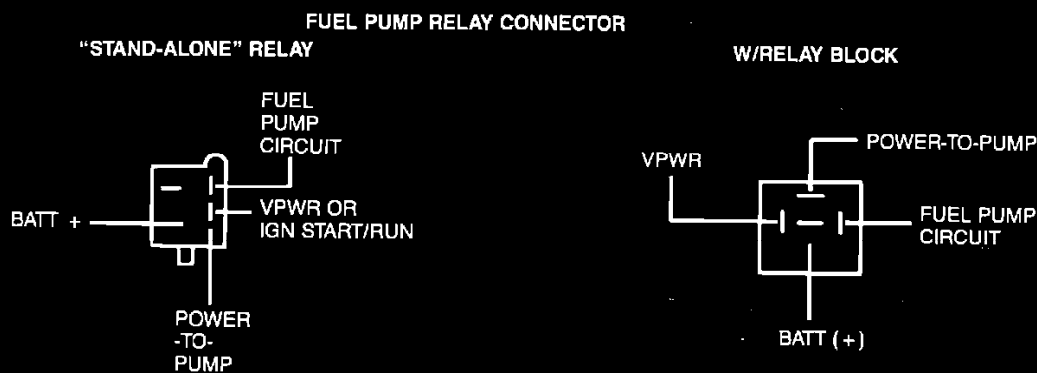

EEC-IV Pinpoint Test

TEST STEP		RESULT	ACTION TO TAKE
J9	CHECK FUEL PUMP CIRCUIT FOR SHORT TO POWER	Yes	GO to J10.
<ul style="list-style-type: none"> • Key off. • Fuel pump relay disconnected. • Disconnect processor 60 pin connector. Inspect for damaged or pushed out pins, corrosion, loose wires, etc. Service as necessary. • Install breakout box, leave processor disconnected. • Key on, engine off. • Measure voltage between Test Pin 22 at the breakout box and battery negative post. • Is voltage less than 1.0 volt? 		No	SERVICE short circuit. RECONNECT all components. ATTEMPT to start vehicle. If vehicle fails to start, REPLACE processor. RERUN Quick Test. (Refer to TESTING PROCEDURES/ QUICK TEST AND DIAGNOSTIC AIDS/ DETAILED QUICK TEST PROCEDURES/ KEY ON ENGINE OFF SELF TEST for quick test procedures.)
J10	CHECK FUEL PUMP CIRCUIT FOR SHORT TO GROUND	Yes	GO to J11.
<ul style="list-style-type: none"> • Key off. • Breakout box installed, processor disconnected. • Fuel pump relay disconnected. • Measure resistance between Test Pin 22 and Test Pins 40 and 60 at the breakout box. • Is resistance greater than 10,000 ohms? 		No	SERVICE short circuit. REMOVE breakout box. RECONNECT all components. RERUN Quick Test. (Refer to TESTING PROCEDURES/ QUICK TEST AND DIAGNOSTIC AIDS/ DETAILED QUICK TEST PROCEDURES/ KEY ON ENGINE OFF SELF TEST for quick test procedures.)
J11	CHECK FUEL PUMP CIRCUIT CONTINUITY	Yes	REPLACE processor. RECONNECT fuel pump relay. RERUN Quick Test. (Refer to TESTING PROCEDURES/ QUICK TEST AND DIAGNOSTIC AIDS/ DETAILED QUICK TEST PROCEDURES/ KEY ON ENGINE OFF SELF TEST for quick test procedures.)
<ul style="list-style-type: none"> • Key off. • Breakout box installed, processor disconnected. • Fuel pump relay disconnected. • Measure resistance between fuel pump circuit at the fuel pump relay vehicle harness connector and Test Pin 22 at the breakout box. • Is resistance less than 5.0 ohms? 		No	SERVICE open circuit. REMOVE break-out box. RECONNECT all components. RERUN Quick Test. (Refer to TESTING PROCEDURES/ QUICK TEST AND DIAGNOSTIC AIDS/ DETAILED QUICK TEST PROCEDURES/ KEY ON ENGINE OFF SELF TEST for quick test procedures.)

EEC-IV Pinpoint Test

TEST STEP		RESULT	ACTION TO TAKE
J20	SERVICE CODE 95/542: DOES ENGINE START		
<p>Service Code 95/542 indicates that one of the following has occurred:</p> <p>No Starts:</p> <ul style="list-style-type: none"> — Inertia switch not reset or electrically open (if in secondary circuit). — Open circuit in or between the fuel pump and FPM circuit connection to the Power-To-Pump circuit. — Poor fuel pump ground <p>Engine Starts:</p> <ul style="list-style-type: none"> — Fuel pump secondary circuit short to power — Fuel pump relay contacts always closed — Open in FPM circuit between processor and connection to the Power-To-Pump circuit. — HEGO short to power (dual HEGO applications). — Faulty processor <p>• Does the engine start?</p>		<p>Yes</p> <p>No</p>	<p>▶ GO to J21 .</p> <p>▶ GO to J25 .</p>
J21	VERIFY THAT FUEL PUMP IS OFF		
<ul style="list-style-type: none"> • Key on, wait 5 seconds. • Listen for motor noise from fuel pump. • Is fuel pump off? 		<p>Yes</p> <p>No</p>	<p>▶ GO to J23 .</p> <p>▶ GO to J22 .</p>
J22	CHECK FOR FUEL PUMP RELAY ALWAYS CLOSED		
<ul style="list-style-type: none"> • Key off. • Locate and disconnect fuel pump relay. • Key on. • Is fuel pump off with relay disconnected? 		<p>Yes</p> <p>No</p>	<p>▶ REPLACE fuel pump relay. RERUN Quick Test (Refer to TESTING PROCEDURES/QUICK TEST AND DIAGNOSTIC AIDS/DETAILED QUICK TEST PROCEDURES/KEY ON ENGINE OFF SELF TEST for quick test procedures)</p> <p>▶ SERVICE short to power in POWER-TO-PUMP/FPM circuit (For applications with Relay Block, also CHECK fuel pump prime plug circuit. REFER to Schematic) RERUN Quick Test (Refer to TESTING PROCEDURES/QUICK TEST AND DIAGNOSTIC AIDS/DETAILED QUICK TEST PROCEDURES/KEY ON ENGINE OFF SELF TEST for quick test procedures)</p>

EEC-IV Pinpoint Test

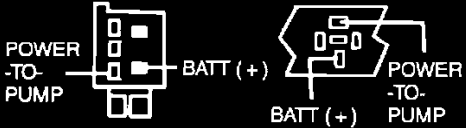
TEST STEP		RESULT	ACTION TO TAKE
J23	CHECK FPM CIRCUIT CONTINUITY		
<ul style="list-style-type: none"> • Key off. • Disconnect processor 60 pin connector. Inspect for damaged or pushed out pins, corrosion, loose wires, etc. Service as necessary. • Install breakout box, leave processor disconnected. • Disconnect fuel pump relay. • Measure resistance between Test Pin 8 at the breakout box and Power-To-Pump circuit at the fuel pump relay vehicle harness connector. <ul style="list-style-type: none"> • Is resistance less than 5.0 ohms?  <p style="text-align: center;">FUEL PUMP RELAY VEHICLE HARNESS CONNECTOR (USE APPLICABLE DRAWING)</p>		<p>Yes</p> <p>▶</p> <p>For dual HEGO applications: GO to J35.</p> <p>All others: REPLACE processor. REMOVE breakout box. RECONNECT fuel pump relay. RERUN Quick Test.</p> <p>(Refer to TESTING PROCEDURES/ QUICK TEST AND DIAGNOSTIC AIDS/ DETAILED QUICK TEST PROCEDURES/ KEY ON ENGINE OFF SELF TEST for quick test procedures.)</p> <p>No</p> <p>▶</p> <p>SERVICE Open circuit. REMOVE breakout box. RECONNECT all components. RERUN Quick Test.</p> <p>(Refer to TESTING PROCEDURES/ QUICK TEST AND DIAGNOSTIC AIDS/ DETAILED QUICK TEST PROCEDURES/ KEY ON ENGINE OFF SELF TEST for quick test procedures.)</p>	
J25	CHECK INERTIA SWITCH		
<ul style="list-style-type: none"> • Key off. • Locate and disconnect fuel pump inertia switch (verify that switch is reset). • Measure resistance of the fuel pump inertia switch. <ul style="list-style-type: none"> • Is resistance less than 5.0 ohms? 		<p>Yes</p> <p>▶</p> <p>RECONNECT inertia switch. GO to FUEL SYSTEMS for open in Power-to-Pump circuit, poor fuel pump ground, open in fuel pump, etc.</p> <p>No</p> <p>▶</p> <p>REPLACE or RESET inertia switch. RERUN Quick Test.</p> <p>(Refer to TESTING PROCEDURES/ QUICK TEST AND DIAGNOSTIC AIDS/ DETAILED QUICK TEST PROCEDURES/ KEY ON ENGINE OFF SELF TEST for quick test procedures.)</p>	

EEC-IV Pinpoint Test

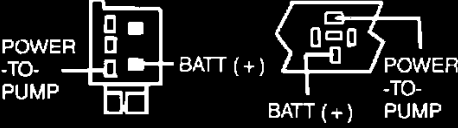
TEST STEP		RESULT	ACTION TO TAKE
J30	SERVICE CODE 96/543: DOES ENGINE START	Yes	For dual HEGO applications: GO to J35. All others: REPLACE processor. RERUN Quick Test. (Refer to TESTING PROCEDURES/QUICK TEST AND DIAGNOSTIC AIDS/ DETAILED QUICK TEST PROCEDURES/KEY ON ENGINE OFF SELF TEST for quick test procedures).
<p>Service Code 96 indicates a fuel pump secondary circuit failure between the BATT(+) supply and the FPM connection to the Power-To-Pump circuit.</p> <p>Possible causes are:</p> <p>No Starts:</p> <ul style="list-style-type: none"> — Open circuit between the BATT(+) supply and the FPM connection to the Power-to-Pump circuit. — Fuel pump relay contacts always open. <p>Engine Starts:</p> <ul style="list-style-type: none"> — HEGO short to power (dual HEGO applications). — Faulty processor. <p>• Does the engine start?</p>		No	GO to J31 .
J31	CHECK FOR BATT(+) TO FUEL PUMP RELAY	Yes	GO to J32 .
<ul style="list-style-type: none"> • Key off. • Measure voltage between BATT(+) circuit at the fuel pump relay and battery negative post. <p>• Is voltage greater than 10.5 volts?</p>  <p style="text-align: center;">FUEL PUMP RELAY VEHICLE HARNESS CONNECTOR (USE APPLICABLE DRAWING)</p>		No	VERIFY integrity of fuse/fuse Link for BATT(+) supply to fuel pump relay. If OK, SERVICE open in BATT(+) circuit. RERUN Quick Test. (Refer to TESTING PROCEDURES/QUICK TEST AND DIAGNOSTIC AIDS/ DETAILED QUICK TEST PROCEDURES/KEY ON ENGINE OFF SELF TEST for quick test procedures).
J32	CHECK FOR VOLTAGE AT POWER-TO-PUMP CIRCUIT TO VERIFY FUEL PUMP RELAY OPERATION	Yes	GO to J33 .
<ul style="list-style-type: none"> • Key off. • Connect DVOM between Power-To-Pump circuit at the fuel pump relay and battery negative post. • Observe DVOM as you activate fuel pump relay (turn key to run for 1 second, then to off for 10 seconds. Repeat 5 times). <p>• Does voltage measure greater than 10.5 volts for about 1 second after key is turned to RUN position during test?</p>		No	DISCONNECT fuel pump relay. INSPECT for damaged pins, corrosion, loose wires, etc. If OK REPLACE fuel pump relay. RERUN Quick Test. (Refer to TESTING PROCEDURES/QUICK TEST AND DIAGNOSTIC AIDS/ DETAILED QUICK TEST PROCEDURES/KEY ON ENGINE OFF SELF TEST for quick test procedures).

EEC-IV Pinpoint Test

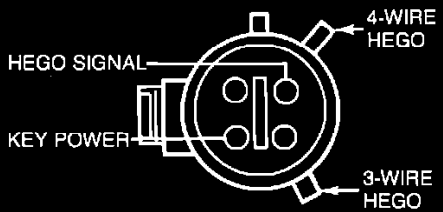
TEST STEP		RESULT	ACTION TO TAKE
J33	CHECK POWER-TO-PUMP CIRCUIT CONTINUITY	Yes	REPLACE processor. RECONNECT fuel pump relay. RERUN Quick Test. (Refer to TESTING PROCEDURES/ QUICK TEST AND DIAGNOSTIC AIDS/ DETAILED QUICK TEST PROCEDURES/ KEY ON ENGINE OFF SELF TEST for quick test procedures.)
	<ul style="list-style-type: none"> • Key off. • Disconnect fuel pump relay. • Measure resistance between Power-to-Pump circuit at the fuel pump relay vehicle harness connector and the battery negative post. • Is resistance less than 10.0 ohms? 	No	SERVICE open in Power -to-Pump circuit between FPM splice and fuel pump relay. REFER to schematic. RERUN Quick Test. (Refer to TESTING PROCEDURES/ QUICK TEST AND DIAGNOSTIC AIDS/ DETAILED QUICK TEST PROCEDURES/ KEY ON ENGINE OFF SELF TEST for quick test procedures.)
J35	CHECK LEFT/FRONT HEGO SENSOR FOR SHORT TO POWER	Yes	GO to J36.
	<p>NOTE: Due to the internal circuitry of the processor, a left/front HEGO signal short to power could produce a Service Code 95/542 or 96/543.</p> <ul style="list-style-type: none"> • Key off. • Disconnect left or front HEGO sensor. • Measure resistance between HEGO signal pin and KEY POWER pin at the HEGO sensor connector. • Is resistance greater than 10,000 ohms? 	No	REPLACE HEGO sensor. RERUN Quick Test. CLEAR Keep Alive Memory. (Refer to TESTING PROCEDURES/QUICK TEST AND DIAGNOSTIC AIDS/DETAILED TEST PROCEDURES/CONTINUOUS MEMORY CODES).

EEC-IV Pinpoint Test

TEST STEP		RESULT	ACTION TO TAKE
J36	CHECK HEGO CIRCUIT FOR SHORT TO POWER	Yes	<p>REPLACE processor. RECONNECT HEGO sensor. RERUN Quick Test.</p> <p>(Refer to TESTING PROCEDURES/QUICK TEST AND DIAGNOSTIC AIDS/DETAILED QUICK TEST PROCEDURES/KEY ON ENGINE OFF SELF TEST for quick test procedures)</p>
<ul style="list-style-type: none"> • Key off. • Left or front HEGO sensor disconnected. • Disconnect processor 60 pin connector. Inspect for damaged or pushed out pins, corrosion, loose wires, etc. Service as necessary. Leave processor disconnected. • Key on. • Measure voltage between the HEGO signal at the HEGO vehicle harness connector and chassis ground. • Is voltage less than 2.0 volts? 		No	<p>SERVICE short circuit. RECONNECT processor and HEGO sensor. RERUN Quick Test. CLEAR Keep Alive Memory.</p> <p>(Refer to TESTING PROCEDURES/QUICK TEST AND DIAGNOSTIC AIDS/DETAILED QUICK TEST PROCEDURES/CONTINUOUS MEMORY CODES.)</p>
<p>The diagram shows a circular 60-pin connector. On the left side, there are two groups of pins: the top group is labeled '4-WIRE HEGO' and the bottom group is labeled '3 WIRE HEGO'. On the right side, there are two individual pins: the top one is labeled 'HEGO SIGNAL' and the bottom one is labeled 'KEY POWER'.</p>			

EEC-IV Pinpoint Test

TEST STEP		RESULT	ACTION TO TAKE
J90	CONTINUOUS MEMORY CODE 95/542: CHECK EEC-IV HARNESS		
<p>A Continuous Memory Code 95/542 indicates that one of the following intermittent conditions has occurred:</p> <ul style="list-style-type: none"> — Open circuit in or between the fuel pump and FPM circuit at the processor (see schematic). — Poor fuel pump ground. — FPM or Power-To-Pump circuit short to power. — Fuel pump relay contacts stuck closed. — Fuel pump circuit activated when processor expected circuit to be off (i.e. fuel system test or prime procedure). — Left/Front HEGO circuit short to power (dual HEGO). <ul style="list-style-type: none"> • Start engine. • Check for engine stall/stumble while performing the following (also, if possible, listen for fuel pump turning off.) <ul style="list-style-type: none"> — Shake, wiggle, bend the Power-To-Pump circuit between the Power-To-Pump pin at the fuel pump relay and the fuel pump. — Shake, wiggle, bend the fuel pump ground circuit from the fuel pump to ground. — Lightly tap the fuel pump to simulate road shock. — For vehicles with the inertia switch in the Power-To-Pump circuit (refer to schematic), lightly tap inertia switch to simulate road shock. • Key off. • Inspect the fuel pump vehicle harness connector and the fuel pump ground for corrosion, damaged pins, etc. • Is fault indicated/found? 		<p>Yes</p> <p>▶</p>	<p>ISOLATE fault and SERVICE as necessary. CLEAR Continuous Memory RERUN Quick Test. (Refer to TESTING PROCEDURES/QUICK TEST AND DIAGNOSTIC AIDS/ DETAILED QUICK TEST PROCEDURES/CONTINUOUS MEMORY CODES for code clearing procedures). (Refer to TESTING PROCEDURES/QUICK TEST AND DIAGNOSTIC AIDS/ DETAILED QUICK TEST PROCEDURES/KEY ON ENGINE OFF SELF TEST for quick test procedures).</p>
		<p>No</p> <p>▶</p>	<p>GO to J91.</p>

EEC-IV Pinpoint Test

TEST STEP		RESULT	ACTION TO TAKE
J91	CHECK FPM CIRCUIT	Yes	ISOLATE fault and SERVICE as necessary. REMOVE breakout box. CLEAR Continuous Memory. RERUN Quick Test. (Refer to TESTING PROCEDURES/ QUICK TEST AND DIAGNOSTIC AIDS/ DETAILED QUICK TEST PROCEDURES/ CONTINUOUS MEMORY CODES) (Refer to TESTING PROCEDURES/ QUICK TEST AND DIAGNOSTIC AIDS/ DETAILED QUICK TEST PROCEDURES/ KEY ON ENGINE OFF SELF TEST for quick test procedures.)
<ul style="list-style-type: none"> • Key off. • Disconnect processor 60 pin connector. Inspect for damaged or pushed out pins, corrosion, loose wires, etc. Service as necessary. • Install breakout box, leave processor disconnected. • Key on, engine off. • Connect a TEST LAMP between Test Pin 8 (Test and Test Pin 37 at the breakout box. • Observe test lamp for an indication of a fault while performing the following (The light will go out when a fault is found, indicating an open): <ul style="list-style-type: none"> — Shake, wiggle, bend the fuel pump monitor circuit between the fuel pump relay (or splice if applicable, see schematic) and the processor. • Is fault indicated? 		No	GO to J92.
J92	CHECK FOR SHORTS TO POWER	Yes	ISOLATE fault and SERVICE as necessary. REMOVE breakout box. RECONNECT processor. CLEAR Continuous Memory . RERUN Quick Test. (Refer to TESTING PROCEDURES/ QUICK TEST AND DIAGNOSTIC AIDS/ DETAILED QUICK TEST PROCEDURES/ CONTINUOUS MEMORY CODES) (Refer to TESTING PROCEDURES/ QUICK TEST AND DIAGNOSTIC AIDS/ DETAILED QUICK TEST PROCEDURES/ KEY ON ENGINE OFF SELF TEST for quick test procedures.)
<ul style="list-style-type: none"> • Key on, engine off. • Breakout box installed, processor disconnected. • Connect a TEST LAMP between Test Pin 8 and Test Pin 40. • Observe test lamp for an indication of a fault while performing the following (The light will turn on when a fault is detected, indicating a short to power. Also, if possible, listen for fuel pump turning on.): <ul style="list-style-type: none"> — Shake, wiggle, bend the fuel pump monitor circuit and Power-To-Pump circuit, especially where they may be in the vicinity of a power circuit. • Lightly tap the fuel pump relay (to simulate road shock). • Is fault indicated? 		No	For dual HEGO applications: GO to J96. All others: For further diagnosis using the EEC-IV Monitor Box, GO to TESTING PROCEDURES/ INTERMITTENT FAULT DIAGNOSIS. If and EEC-IV Monitor Box is not available, GO to J99.

EEC-IV Pinpoint Test

TEST STEP		RESULT	ACTION TO TAKE
J93	CONTINUOUS MEMORY CODE 96/543: CHECK FOR CONTINUOUS MEMORY CODE 87/556		
<ul style="list-style-type: none"> Is Continuous Memory Code 87 or 556 also present? 		Yes	GO to J95.
		No	GO to J94.
J94	CHECK EEC-IV HARNESS		
<p>A Continuous Memory Code 96/543, without the presence of a Continuous Memory Code 87/556, indicates that during vehicle operation, one of the following has occurred:</p> <ul style="list-style-type: none"> Open in the BATT(+) circuit between BATT(+) and the fuel pump relay. Fuel pump relay contacts opened. Open in the Power-To-Pump circuit from the fuel pump relay to the FPM splice, if applicable (see schematic). Left/Front HEGO circuit short to power (dual HEGO). <ul style="list-style-type: none"> Start engine. Check for engine stall/stumble while performing the following (also, if possible, listen for fuel pump turning off): <ul style="list-style-type: none"> Shake, wiggle, bend the BATT(+) circuit from BATT(+) to the fuel pump relay. Lightly tap the fuel pump relay (to simulate road shock). Shake, wiggle, bend the Power-To-Pump circuit from the fuel pump relay to the FPM splice, if applicable (See schematic). Key off. Inspect the fuel pump relay connectors and BATT(+) connector terminal for corrosion, damaged pins, etc. <ul style="list-style-type: none"> Is fault indicated/found? 		Yes	ISOLATE fault and SERVICE as necessary. CLEAR Continuous Memory RERUN Quick Test. (Refer to TESTING PROCEDURES/QUICK TEST AND DIAGNOSTIC AIDS/ DETAILED QUICK TEST PROCEDURES/CONTINUOUS MEMORY CODES for code clearing procedures). (Refer to TESTING PROCEDURES/QUICK TEST AND DIAGNOSTIC AIDS/ DETAILED QUICK TEST PROCEDURES/KEY ON ENGINE OFF SELF TEST for quick test procedures).
		No	Under certain conditions, a Continuous Memory Code 96/543 may have been set without a Continuous Memory Code 87/556, even though a fault has occurred in the fuel pump primary circuit. GO to J95 to check the fuel pump primary circuit.

EEC-IV Pinpoint Test

TEST STEP		RESULT	ACTION TO TAKE
J95	CONTINUOUS MEMORY CODE 87/556: CHECK EEC-IV HARNESS	Yes	ISOLATE fault and SERVICE as necessary. CLEAR Continuous Memory. RERUN Quick Test. (Refer to TESTING PROCEDURES/ QUICK TEST AND DIAGNOSTIC AIDS/ DETAILED QUICK TEST PROCEDURES/ CONTINUOUS MEMORY CODES for code clearing procedures.) (Refer to TESTING PROCEDURES/ QUICK TEST AND DIAGNOSTIC AIDS/ DETAILED QUICK TEST PROCEDURES/ KEY ON ENGINE OFF SELF TEST for quick test procedures.)
	<p>A Continuous Memory Code 87 indicates that a fuel pump primary circuit failure has occurred during vehicle operation. Possible causes are:</p> <ul style="list-style-type: none"> — Open in VPWR circuit between the EEC power relay and the fuel pump relay. — Open coil in fuel pump relay. — Open in fuel pump circuit (Pin 22). — Faulty inertia switch. <ul style="list-style-type: none"> • Start engine. • Check for engine stall/stumble while performing the following (also, if possible, listen for fuel pump turning off): <ul style="list-style-type: none"> — Shake, wiggle, bend the VPWR circuit between the EEC power relay and the fuel pump relay. For vehicles with the inertia switch in the VPWR circuit (refer to schematic), lightly tap the inertia switch to simulate road shock. — Shake, wiggle, bend the EEC-IV vehicle harness fuel pump circuit (Test Pin 22) between the processor and the fuel pump relay. — Lightly tap the fuel pump relay to simulate road shock. • Key off. • Inspect the processor 60 pin connector and the fuel pump relay connectors for corrosion, damaged pins, etc. • Is fault indicated/found? 	No	<p>For dual HEGO applications with a code 96/543 only: GO to J96</p> <p>ALL others: For further diagnosis using the EEC-IV Monitor Box, GO to TESTING PROCEDURES/INTERMITTENT FAULT DIAGNOSIS.</p> <p>If an EEC-IV Monitor is not available, GO to J99.</p> <p>Unable to duplicate and/or identify fault at this time. For further diagnosis using the EEC-IV Monitor Box, REFER to TESTING PROCEDURES/INTERMITTENT FAULT DIAGNOSIS.</p> <p>All others, CLEAR Continuous Memory. RERUN Quick Test. (Refer to TESTING PROCEDURES/ QUICK TEST AND DIAGNOSTIC AIDS/ DETAILED QUICK TEST PROCEDURES/ CONTINUOUS MEMORY CODES for code clearing procedures.)</p> <p>(Refer to TESTING PROCEDURES/ QUICK TEST AND DIAGNOSTIC AIDS/ DETAILED QUICK TEST PROCEDURES/ KEY ON ENGINE OFF SELF TEST for quick test procedures.)</p>

EEC-IV Pinpoint Test

TEST STEP		RESULT	ACTION TO TAKE
J96	CHECK LEFT/FRONT HEGO CIRCUIT FOR SHORT TO POWER		
<p>NOTE: Due to the internal circuitry of the processor, an intermittent left/front HEGO signal short to power could produce a Continuous Memory Service Code 95/542 or 96/543.</p> <ul style="list-style-type: none"> • Key off. • For Continuous Memory Code 96/543, install breakout box. • Breakout box installed, processor disconnected. • Connect a test lamp between the left/front HEGO test pin and test pin 40 at the breakout box <p>• Observe test lamp for an indication of a fault while performing the following (The light will turn on bright when a fault is detected):</p> <ul style="list-style-type: none"> - Shake, wiggle, bend the left/front HEGO circuit from the HEGO sensor to the processor. - Lightly tap the HEGO sensor (To simulate road shock). <ul style="list-style-type: none"> • Is fault indicated? 		<p>Yes</p> <p>No</p>	<p>ISOLATE fault and SERVICE as necessary. REMOVE breakout box. RECONNECT processor. CLEAR Keep Alive Memory . RERUN Quick Test. (Refer to TESTING PROCEDURES/QUICK TEST AND DIAGNOSTIC AIDS/ DETAILED QUICK TEST PROCEDURES/CONTINUOUS MEMORY CODES for code clearing procedures).. (Refer to TESTING PROCEDURES/QUICK TEST AND DIAGNOSTIC AIDS/ DETAILED QUICK TEST PROCEDURES/KEY ON ENGINE OFF SELF TEST for quick test procedures)..</p> <p>For further diagnosis using the EEC-IV Monitor Box, Go to TESTING PROCEDURES/ INTERMITTENT FAULT DIAGNOSIS.</p> <p>If an EEC-IV Monitor Box is not available Go to J99 .</p>

EEC-IV Pinpoint Test

J99 ROAD TEST

The purpose of the road test is to identify an area of concern by monitoring certain controlled parameters while trying to re-create a driveability or MIL light symptom.

Note

A basic working knowledge of the EEC-IV system is critical to effectively analyze road test data.

WARNING

THIS ROAD TEST IS A SUGGESTED BUT OPTIONAL PROCEDURE. ALL APPLICABLE SAFETY PROCEDURES AND TRAFFIC LAWS MUST BE FOLLOWED. IN ORDER FOR A ROAD TEST TO BE PERFORMED IT IS REQUIRED THAT ANOTHER PERSON ACCOMPANY THE DRIVER. THE ACCOMPANYING PERSON CAN MAKE MEASUREMENTS, OBSERVE CHANGES AND RECORD NOTES. IF FOR SOME REASON THIS TEST IS NOT PERFORMED, RETURN TO SECTION 2 FOR OTHER POSSIBLE CAUSES.

PREPARE VEHICLE FOR A ROAD TEST

- Install breakout box, if applicable.
- Breakout box installed, processor connected.
- Install fuel pressure gauge and MAP/BP tester (optional).
- Other materials needed; DVOM, pencil, paper, appropriate schematic/pin usage sheet (from SCHEMATIC DIAGRAMS)

PRELEMINARY POWER/GROUND CHECKS

- With the key ON and a DVOM referenced to the battery negative post, check the following signals for correct values.
POWERS: KAPWR > 10.5V (pin 1); VPWR > 10.5V (pins 37/57); VREF 5±1V (pin 26)
GROUNDS (all = 0±.5V): PWR GND (pins 40/60); SIG RTN (pin 46); IGN GND (pin 16)
OPTIONAL GROUNDS: HEGO GND (pin 49); CSE GND (pin 20); MAF RTN (pin 9 or 15)

OBTAINING OTHER NEEDED INFORMATION AND MATERIALS BEFORE THE ROAD TEST

- Refer to the Symptom Charts in TESTING PROCEDURES/INTERMITTENT FAULT DIAGNOSIS/SYMP TOM CHARTS, looking at the chart(s) that closest resembles the vehicle's driveability or MIL light symptom. Before the road test perform the Visual/Mechanical Checks that are listed. Next, list the EEC-IV sensors and actuators in the order given. These circuits, along with the FP/FPM signal(s), are the main signals that will be monitored.
- Refer to the proper Diagnostic Reference Value Sheet in TESTING PROCEDURES/INTERMITTENT FAULT DIAGNOSIS/DIAGNOSTIC REFERENCE VALUES. Although these charts were designed for use with the EEC-IV Monitor Box, most of the values can be read using the breakout box and a DVOM (with the DVOM referenced to ground all values in DCV units can be used; other values may also be helpful, ex. MAP Hz using the MAP/BP tester). Also refer to TESTING PROCEDURES/INTERMITTENT FAULT DIAGNOSIS/GRAPHS AND CHARTS.

EEC-IV Pinpoint Test

J99 ROAD TEST

- The use of test lamp(s) and a DVOM may also aid diagnosis. For example, with a Continuous Memory 87/556 (fuel pump primary circuit failure) and a surge/stall symptom, a test lamp could be connected at the fuel pump relay between the VPWR circuit and ground, with a DVOM connected between the Fuel Pump (FP) circuit at the relay and Test Pin 1 (KAPWR) at the breakout box. Under normal drive conditions the lamp will be on and the DVOM will read battery voltage (if the vehicle stalls, the processor will "unground" the FP circuit and the DVOM voltage will be low. If the problem is in the fuel pump wiring the lamp/voltage should change just before the symptom occurs). If the VPWR lamp goes out, the problem is in the VPWR supply to the relay. If the lamp stayed on, the DVOM voltage remained high and a Continuous Memory 87/556 was set again, REPLACE the fuel pump relay. If only the FP voltage went low, the problem is either in the FP circuit or the processor. The DVOM could now be connected between Test Pin 22 (FP) and Test Pin 1 (KAPWR) at the breakout box. If, just before the symptom occurs, the voltage goes low, REPLACE the processor; if the voltage stays high, the problem is in the FP circuit wiring. For the fuel pump secondary circuit codes (95/542, 96/543), the BATT(+), Power-to-Pump and FPM circuits could be similarly monitored.

NOTE: Due to the low resistance of some test lamps, it is recommended that a DVOM or equivalent high resistance testing device be used when monitoring processor output circuits.

ROAD TEST

- Drive the vehicle to create the conditions so that the symptom will occur. If the DRIVEABILITY WORKSHEET from INFO TYPE/TECHNICAL MANAGEMENT SUPPORT has been completed, this information may help when trying to re-create the symptom.
- When the symptom occurs, the accompanying passenger should observe changes in listed EEC-IV signals. Information about the symptom, operating condition value of the EEC-IV signal or other notes should be recorded onto paper.
- If you are unable to duplicate the symptom, it may still be helpful to verify that the EEC-IV values are in the expected range.

ANALYZING THE DATA

- Once the road test is completed, the results need to be analyzed to locate and repair the exact fault which caused the symptom.
- If no problem is identified, return to DIAGNOSTIC ROUTINES for other possible causes of the symptom.

EEC-IV Pinpoint Test

Note

You should enter this Pinpoint Test only when you have been directed here from Quick Test.

Remember

To prevent the replacement of good components, be aware that the following non-EEC areas may be at fault:

- Thermoactor System
 - Belt
 - Pump
 - Valve
- Base Engine
 - Blocked Thermoactor Air Passages

This Pinpoint Test is intended to diagnose only the following:

- AM1 and AM2 Solenoid Valve Assemblies (-9H465-)
- Harness circuits: AM1/AM2 and VPWR
- Vacuum Supply
- Processor Assembly (-12A650-)

EEC-IV Pinpoint Test

Pinpoint Test Schematic

ALL OTHERS

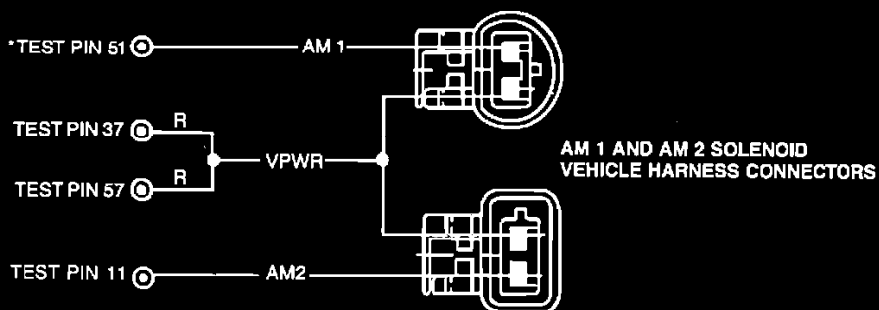

*TEST PINS LOCATED ON BREAKOUT BOX.
ALL HARNESS CONNECTORS VIEWED INTO MATING SURFACE.

	Test Pin 11 AM2	Test Pin 51 AM1
Application	Wire Color	Wire Color
4.9L, 5.0L, 5.8L E-Series/ F-Series/Bronco	W/BR	W/O

EEC-IV Pinpoint Test

TEST STEP		RESULT	ACTION TO TAKE
KC1	SERVICE CODES 44/311, 45/312, 46/313 AND 94/314: VERIFY VACUUM LINE ROUTING		
	<p>Service Code 44/311, 94/314 indicates that Thermactor Air system is inoperative.</p> <p>Service Code 45/312 indicates that Thermactor air is misdirected.</p> <p>Service Code 46/313 indicates that Thermactor is not being bypassed when requested.</p> <p>Possible causes:</p> <ul style="list-style-type: none"> — Vacuum hoses leaking, blocked, or kinked. — Diverter valve, thermactor pump inoperative. — Air Management Solenoid(s) defective, blocked. • Verify proper vacuum line routing to the AM1/AM2 solenoids and to the bypass diverter valve. Refer to VECI decal. • Check for kinked or blocked vacuum lines. • Check for kinked or blocked air hoses. • Check for disconnected or cracked vacuum lines. • Were any problems found? 	<p>Yes</p> <p>No</p>	<p>SERVICE vacuum lines as necessary. RERUN Quick Test. (Refer to TESTING PROCEDURES/QUICK TEST AND DIAGNOSTIC AIDS/DETAILED QUICK TEST PROCEDURES/KEY ON ENGINE OFF SELF TEST for quick test procedures.)</p> <p>For Service Code 44/311, 94/314: GO to KC4 .</p> <p>For Service Code 45/312: GO to KC2 .</p> <p>For Service Code 46/313: GO to KC3 .</p>
KC2	ATTEMPT TO ELIMINATE SERVICE CODE 45/312		
	<ul style="list-style-type: none"> • Disconnect vacuum line on diverter valve and cap vacuum line. • Key off. • Repeat Engine Running Self-Test and record service codes. (Refer to TESTING PROCEDURES/QUICK TEST AND DIAGNOSTIC AIDS/DETAILED QUICK TEST PROCEDURES/KEY ON ENGINE RUNNING SELF TEST for test procedures). • Is Code 45 or 312 present? 	<p>Yes</p> <p>No</p>	<p>EEC-IV system OK. REFER to EMISSION CONTROLS for Thermactor System diagnosis.</p> <p>GO to KC4 .</p>
KC3	ATTEMPT TO ELIMINATE SERVICE CODE 46/313		
	<ul style="list-style-type: none"> • Disconnect vacuum line on bypass valve (or right bypass valve on 7.0L) and cap vacuum line. • Key off. • Repeat Engine Running Self-Test and record codes. (Refer to TESTING PROCEDURES/QUICK TEST AND DIAGNOSTIC AIDS/DETAILED QUICK TEST PROCEDURES/KEY ON ENGINE RUNNING SELF TEST for test procedures). • Is Code 46 or 313 present? 	<p>Yes</p> <p>No</p>	<p>EEC-IV system OK. REFER to EMISSION CONTROLS for Thermactor System diagnosis.</p> <p>GO to KC4 .</p>

EEC-IV Pinpoint Test

TEST STEP		RESULT	ACTION TO TAKE
KC4	ENTER OUTPUT STATE CHECK		
<p>NOTE: Do not use STAR tester for this Step, use a VOM/DVOM.</p> <ul style="list-style-type: none"> • Key off. • Disconnect electrical connector on the speed control servo; if equipped. • DVOM on 20 volt scale. • Connect DVOM negative test lead to STO circuit at the Self-Test connector and positive test lead to battery positive. • Jumper STI circuit to SIG RTN at the Self-Test connector. • Perform Key On Engine Off Self-Test until the completion of the Continuous Memory Test Codes. • DVOM will indicate less than one volt when test is complete. • Depress and release the throttle. • Does voltage increase? 		<p>Yes</p> <p>No</p>	<p>▶ REMAIN in Output State Check. GO to KC5.</p> <p>▶ DEPRESS throttle to WOT and RELEASE. If STO voltage does not go high, leave equipment hooked up and GO to Pinpoint Test QC, Step QC1.</p>
KC5	CHECK SOLENOIDS ELECTRICAL OPERATION		
<ul style="list-style-type: none"> • DVOM on 20 volt scale. • Disconnect both solenoids. • Connect DVOM positive test lead to VPWR circuit and negative test lead to one solenoid vehicle harness connector. • While observing DVOM depress and release the throttle several times (to cycle output On and Off). • Repeat for the other solenoid. Connect positive test lead to VPWR circuit and negative test lead to the other solenoid vehicle harness connector. • Does each solenoid circuit cycle 0.5 volt or greater? 		<p>Yes</p> <p>No</p>	<p>▶ REMAIN in Output State Check. RECONNECT solenoids. GO to KC6.</p> <p>▶ REMOVE jumper. GO to KC9.</p>

EEC-IV Pinpoint Test

TEST STEP		RESULT	ACTION TO TAKE
KC6	CHECK SOLENOIDS FOR VACUUM CYCLING /		
<ul style="list-style-type: none"> Install vacuum pump to the AM1 solenoid vacuum supply port and install a vacuum gauge to the AM1 output port. While cycling outputs On and Off (by depressing and releasing throttle), observe the vacuum gauge at the output. <p>NOTE: Maintain vacuum at source.</p> <ul style="list-style-type: none"> Repeat for AM2 solenoid. Connect vacuum pump to the AM2 solenoid vacuum supply port and connect a vacuum gauge to the AM2 output port. Cycle output On and Off. Does each solenoid cycle vacuum output On and Off? 		<p>Yes</p> <p>No</p>	<p>EXIT output state check. GO to KC7.</p> <p>REPLACE solenoid assembly. RERUN Quick Test. (Refer to TESTING PROCEDURES/QUICK TEST AND DIAGNOSTIC AIDS/ DETAILS QUICK TEST PROCEDURES/KEY ON ENGINE OFF SELF TEST for quick test procedures).</p>
KC7	CHECK SOLENOIDS FOR INTERNAL VACUUM LEAKS		
<ul style="list-style-type: none"> Vacuum pump connected to the supply port and vacuum gauge connected to the output port of one solenoid. Apply 15 in-Hg vacuum and observe gauge. Repeat steps above for the other solenoid. Does vacuum gauge reading hold for each solenoid? 		<p>Yes</p> <p>No</p>	<p>SERVICE vacuum hose blockage or leakage from manifold to solenoids and control valves. If OK, INSPECT both the Thermactor Air Tube and the air passages in the Engine Head for carbon blockage. RERUN Quick Test. (Refer to TESTING PROCEDURES/QUICK TEST AND DIAGNOSTIC AIDS/ DETAILS QUICK TEST PROCEDURES/KEY ON ENGINE OFF SELF TEST for quick test procedures).</p> <p>REPLACE solenoid assembly. RERUN Quick Test. (Refer to TESTING PROCEDURES/QUICK TEST AND DIAGNOSTIC AIDS/ DETAILS QUICK TEST PROCEDURES/KEY ON ENGINE OFF SELF TEST for quick test procedures).</p>

EEC-IV Pinpoint Test

TEST STEP		RESULT	ACTION TO TAKE
KC8	CHECK VOLTAGE OF VPWR CIRCUIT		
<p>Service Code 81/553, 82/552 indicates that voltage output for Thermactor Air solenoid(s) did not change when activated.</p> <p>Possible causes:</p> <ul style="list-style-type: none"> — Solenoid circuits shorted to power. — Solenoid circuits open or grounded. — Solenoid resistance out of range. — Faulty processor. <ul style="list-style-type: none"> • Disconnect solenoid connector for both solenoids. • Key on, engine off. • Measure voltage between VPWR circuit and battery ground of one solenoid, then repeat for the other solenoid. • Is each voltage greater than 10.5 volts? 		<p>Yes</p> <p>No</p>	<p>GO to KC9.</p> <p>SERVICE harness circuit open. RECONNECT solenoids. RERUN Quick Test.</p> <p>(Refer to TESTING PROCEDURES/QUICK TEST AND DIAGNOSTIC AIDS/DETAILED QUICK TEST PROCEDURES/KEY ON ENGINE OFF SELF TEST for quick test procedures)</p>
KC9	MEASURE SOLENOID RESISTANCE		
<ul style="list-style-type: none"> • Key off. • Disconnect both solenoid connectors and measure solenoid resistances. • Is each resistance between 50 and 100 ohms? 		<p>Yes</p> <p>No</p>	<p>GO to KC10.</p> <p>REPLACE AM1/AM2 solenoid assembly. RECONNECT solenoids. RERUN Quick Test.</p> <p>(Refer to TESTING PROCEDURES/QUICK TEST AND DIAGNOSTIC AIDS/DETAILED QUICK TEST PROCEDURES/KEY ON ENGINE OFF SELF TEST for quick test procedures)</p>
KC10	CHECK CIRCUIT CONTINUITY		
<ul style="list-style-type: none"> • Key off. • Disconnect processor 60 pin connector. Inspect for damaged or pushed out pins, corrosion, loose wires, etc. Service as necessary. • Install breakout box, leave processor disconnected. • Measure resistance between Test Pin 51 at breakout box and AM1 circuit at vehicle harness connector. • Measure resistance between Test Pin 11 (Test Pin 32 for 5.0L MA SEFI) at the breakout box and AM2 circuit at vehicle harness connector. • Is each resistance less than 5.0 ohms? 		<p>Yes</p> <p>No</p>	<p>GO to KC11.</p> <p>SERVICE harness open circuit. REMOVE breakout box. RECONNECT processor and solenoids. RERUN Quick Test.</p> <p>(Refer to TESTING PROCEDURES/QUICK TEST AND DIAGNOSTIC AIDS/DETAILED QUICK TEST PROCEDURES/KEY ON ENGINE OFF SELF TEST for quick test procedures)</p>

EEC-IV Pinpoint Test

TEST STEP		RESULT	ACTION TO TAKE
KC11	CHECK FOR SHORT TO GROUND	Yes	GO to KC12 .
<ul style="list-style-type: none"> • Key off. • Breakout box installed, processor disconnected. • Disconnect both solenoids. • Measure resistance between Test Pin 51 and Test Pins 40, 46 and 60 and between Test Pin 11 and Test Pins 40, 46 and 60 at the breakout box. <p>• Is each resistance greater than 10,000 ohms?</p>		No	SERVICE short to ground. REMOVE breakout box. RECONNECT processor and solenoids. RERUN Quick Test. (Refer to TESTING PROCEDURES/QUICK TEST AND DIAGNOSTIC AIDS/ DETAILED QUICK TEST PROCEDURES/KEY ON ENGINE OFF SELF TEST for quick test procedures).
KC12	CHECK FOR SHORT TO POWER	Yes	REPLACE processor. REMOVE breakout box. RECONNECT AM1/ AM2 solenoid. RERUN Quick Test. (Refer to TESTING PROCEDURES/QUICK TEST AND DIAGNOSTIC AIDS/ DETAILED QUICK TEST PROCEDURES/KEY ON ENGINE OFF SELF TEST for quick test procedures).
<ul style="list-style-type: none"> • Key off. • Breakout box installed, processor disconnected. • Both solenoids disconnected. • Measure resistance between Test Pin 51 and Test Pins 37 and 57, SEFI or Test Pin 31 on 5.0L Thunderbird/Cougar) and between Test Pin 11 and Test Pins 37 and 57 at the breakout box. <p>• Is each resistance greater than 10,000 ohms?</p>		No	SERVICE short to power. REMOVE breakout box. RECONNECT processor and solenoids. RERUN Quick Test. (Refer to TESTING PROCEDURES/QUICK TEST AND DIAGNOSTIC AIDS/ DETAILED QUICK TEST PROCEDURES/KEY ON ENGINE OFF SELF TEST for quick test procedures). If code is present, REPLACE processor.

EEC-IV Pinpoint Test

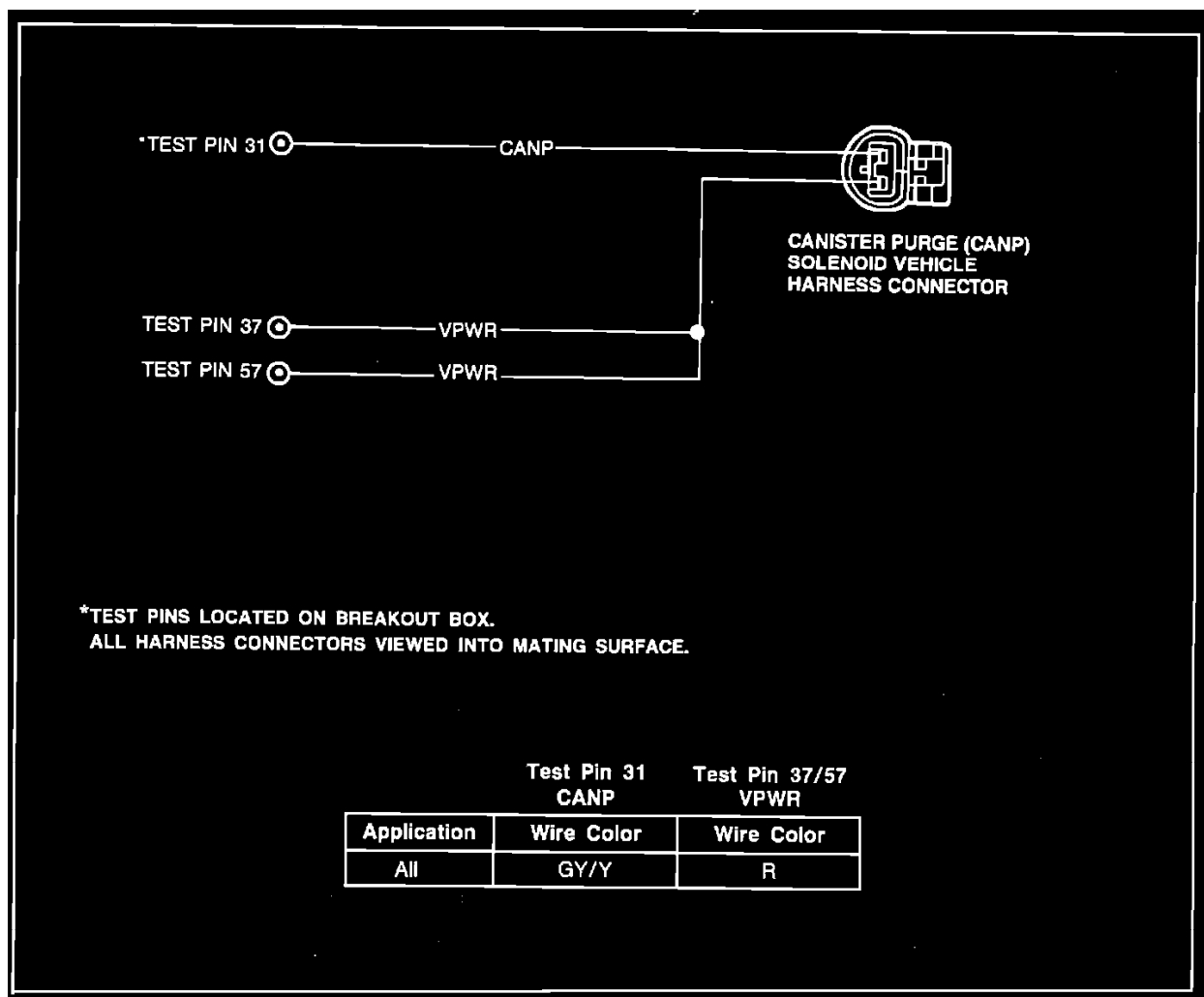

EEC-IV Pinpoint Test

Note

You should enter this Pinpoint Test only when you have been directed here from Quick Test.

Remember

This Pinpoint Test is intended to diagnose only the following:

- CANP solenoid(s) (9C915)
- Harness circuits: CANP and VPWR
- Processor assembly (12A650)

EEC-IV Pinpoint Test

TEST STEP		RESULT	ACTION TO TAKE
KD1	ENTER OUTPUT STATE CHECK		
<p>NOTE: Do not use STAR tester for this step, use VOM/DVOM.</p> <ul style="list-style-type: none"> • Key off. • Disconnect electrical connector on the speed control servo; if equipped. • DVOM on 20 volt scale. • Connect DVOM negative test lead to STO circuit at Self-Test connector and positive test lead to battery positive. • Jumper STI circuit to SIG RTN at the Self-Test connector. • Perform Key On Engine Off Self-Test until the completion of the Continuous Test Codes. (Refer to TESTING PROCEDURES/QUICK TEST AND DIAGNOSTIC AIDS/DETAILED QUICK TEST PROCEDURES/KEY ON ENGINE OFF SELF TEST for quick test procedures). • DVOM will indicate less than 1.0 volt when test is completed. • Depress and release the throttle. • Does voltage increase? 		<p>Yes</p> <p>No</p>	<p>▶ REMAIN in Output State Check. GO to KD2.</p> <p>▶ DEPRESS throttle to WOT and release. If STO voltage does not go high, leave equipment hooked up and GO to Pinpoint Test QC, Step QC1</p>
KD2	CHECK CANISTER PURGE (CANP) SOLENOID ELECTRICAL OPERATION		
<ul style="list-style-type: none"> • Key on, engine off. • Disconnect CANP solenoid. • Connect DVOM positive test lead to VPWR circuit and negative test lead to CANP circuit at the CANP solenoid vehicle harness connector. • DVOM on 20 volt scale. • While observing DVOM depress and release the throttle several times to cycle output. • Does CANP circuit cycle 0.5 volt or greater? 		<p>Yes</p> <p>No</p>	<p>▶ REMAIN in Output State Check. GO to KD3.</p> <p>▶ REMOVE jumper. GO to KD6.</p>

EEC-IV Pinpoint Test

TEST STEP		RESULT	ACTION TO TAKE
KD3	CHECK CANP SOLENOID FOR VACUUM LEAKS	Yes	REMAIN in Output State Check. Leave vacuum pump setup in place. GO to KD4 .
	<ul style="list-style-type: none"> • Key on, engine off. • CANP solenoid disconnected. • Disconnect vacuum hose at CANP solenoid on manifold vacuum side of CANP solenoid. • Apply 16 in-Hg (53 kPa) of vacuum to manifold vacuum side of CANP solenoid. • Does CANP solenoid hold vacuum for 20 seconds? 	No	REPLACE CANP solenoid. RERUN Quick Test. (Refer to TESTING PROCEDURES/QUICK TEST AND DIAGNOSTIC AIDS/DETAILED QUICK TEST PROCEDURES/KEY ON ENGINE OFF SELF TEST for quick test procedures) If symptom is still present, GO to EMISSION CONTROLS for evaporative emission system diagnosis.
KD4	CHECK CANP SOLENOID FOR MECHANICAL OPERATION	Yes	CHECK hose from CANP solenoid to canister for cracks, leaks, etc. If OK, REMOVE Jumper from STI to SIGNAL RETURN. GO to KD5 .
	<ul style="list-style-type: none"> • While remaining in output state check, reconnect CANP solenoid. • Apply 16 in-Hg (53 kPa) of vacuum to manifold vacuum side of CANP solenoid. • Depress and release throttle. • Is vacuum released? 	No	CHECK hose from CANP solenoid to canister for blockage or kinks. If OK, REPLACE CANP solenoid. RERUN Quick Test. (Refer to TESTING PROCEDURES/QUICK TEST AND DIAGNOSTIC AIDS/DETAILED QUICK TEST PROCEDURES/KEY ON ENGINE OFF SELF TEST for quick test procedures.)

EEC-IV Pinpoint Test

TEST STEP		RESULT	ACTION TO TAKE
KD5	CHECK FOR VACUUM TO CANP SOLENOID		
<ul style="list-style-type: none"> • Disconnect vacuum hose at CANP solenoid at manifold vacuum side. • Start engine. • Is vacuum present at engine vacuum hose? 		Yes	▶ EEC-IV system OK. If a symptom is still present, GO to EMISSION CONTROLS for evaporative emission system diagnosis.
		No	▶ CHECK vacuum line for proper routing, kinks, leak or blockage. If OK, REFER to ENGINE MECHANICAL for probable subjects affecting engine vacuum.
KD6	SERVICE CODE 85/565 OR 569: CHECK CANP SOLENOID RESISTANCE		
<p>Service Code 85/565 or 569 indicates a failure in the Canister Purge solenoid (CANP) circuit.</p> <p>With Dual CANP system: Code 565 refers to CANP 1, Code 569 refers to CANP 2.</p> <p>Possible causes are:</p> <ul style="list-style-type: none"> — Faulty CANP solenoid — Open harness — Shorted (Power or Ground) harness — Faulty processor. <ul style="list-style-type: none"> • Key off. • Disconnect appropriate CANP solenoid. • Measure CANP solenoid resistance. • Is resistance between 40 and 90 ohms? 		Yes	▶ GO to KD7.
		No	▶ REPLACE CANP solenoid. RERUN Quick Test. (Refer to TESTING PROCEDURES/ QUICK TEST AND DIAGNOSTIC AIDS/ DETAILED QUICK TEST PROCEDURES/ KEY ON ENGINE OFF SELF TEST for quick test procedures.)
KD7	CHECK VPWR CIRCUIT VOLTAGE		
<ul style="list-style-type: none"> • Key on, engine off. • Appropriate CANP solenoid disconnected. • Measure voltage between VPWR at the CANP solenoid vehicle harness connector and battery ground. • Is voltage greater than 10.5 volts? 		Yes	▶ GO to KD8.
		No	▶ SERVICE open harness circuit. RECONNECT CANP solenoid. RERUN Quick Test. (Refer to TESTING PROCEDURES/ QUICK TEST AND DIAGNOSTIC AIDS/ DETAILED QUICK TEST PROCEDURES/ KEY ON ENGINE OFF SELF TEST for quick test procedures.)

EEC-IV Pinpoint Test

TEST STEP		RESULT	ACTION TO TAKE
KD8	CHECK CONTINUITY OF CANP CIRCUIT		
<ul style="list-style-type: none"> • Key off. • Appropriate CANP solenoid disconnected. • Disconnect processor 60 pin connectors. Inspect for damaged or pushed out pins, corrosion, loose wires, etc. Service as necessary. • Install breakout box, leave processor disconnected. • Measure resistance between Test Pin 11, 31 or Pin 54 (refer to schematic) at the breakout box and CANP circuit at the CANP solenoid vehicle harness connector. • Is resistance less than 5 ohms? 		Yes No	GO to KD9. SERVICE open circuit. REMOVE breakout box. RECONNECT all components. RERUN Quick Test. (Refer to TESTING PROCEDURES/ QUICK TEST AND DIAGNOSTIC AIDS/ DETAILED QUICK TEST PROCEDURES/ KEY ON ENGINE OFF SELF TEST for quick test procedures.)
KD9	CHECK CANP CIRCUIT FOR SHORT TO GROUND		
<ul style="list-style-type: none"> • Key off. • Appropriate CANP solenoid disconnected. • Breakout box installed, processor disconnected. • Measure resistance between Test Pin 11, 31 or Pin 54 (refer to schematic) and Test Pins 40, 46 and 60 at the breakout box. • Is each resistance greater than 10,000 ohms? 		Yes No	GO to KD10 . SERVICE short to ground. REMOVE breakout box. RECONNECT all components. RERUN Quick Test. (Refer to TESTING PROCEDURES/ QUICK TEST AND DIAGNOSTIC AIDS/ DETAILED QUICK TEST PROCEDURES/ KEY ON ENGINE OFF SELF TEST for quick test procedures.)
KD10	CHECK CANP CIRCUIT FOR SHORT TO POWER		
<ul style="list-style-type: none"> • Key off. • CANP solenoid disconnected. • Breakout box installed, processor disconnected. • Measure resistance between Test Pin 11, 31 or Pin 54 (refer to schematic) and Test Pins 37 and 57 at the breakout box. • Is each resistance greater than 10,000 ohms? 		Yes No	REPLACE processor. REMOVE breakout box. RECONNECT all components. RERUN Quick Test. (Refer to TESTING PROCEDURES/ QUICK TEST AND DIAGNOSTIC AIDS/ DETAILED QUICK TEST PROCEDURES/ KEY ON ENGINE OFF SELF TEST for quick test procedures.) SERVICE short to power. REMOVE breakout box. RECONNECT all components. REPEAT Quick Test. If code is repeated, REPLACE processor. RERUN Quick Test. (Refer to TESTING PROCEDURES/ QUICK TEST AND DIAGNOSTIC AIDS/ DETAILED QUICK TEST PROCEDURES/ KEY ON ENGINE OFF SELF TEST for quick test procedures.)

EEC-IV Pinpoint Test

Note

You should enter this Pinpoint Test only when you have been directed here from Quick Test or Pinpoint Test S.

Remember

To prevent the replacement of good components, be aware that the following non-EEC areas may be at fault:

- Engine not up to operating temperature
- Engine over operating temperature
- A/C input (electrical problem)
- Throttle Speed Control Linkage
- Throttle Sticking or Linkage Binding.

This Pinpoint Test is intended to diagnose only the following:

- Rpm in Self-Test only
- ISC Solenoid (9F715)
- Harness circuits: ISC and VPWR
- Processor Assembly (12A650)

EEC-IV Pinpoint Test

Pinpoint Test Schematic



Test Pin 21	ISC
Application	Wire Color
Aerostar (4.0L)	O/BK
F-Series	GY/W
All Others	W/LB

Test Pin 37 and 57	VPWR
Application	Wire Color
All	R

EEC-IV Pinpoint Test

TEST STEP		RESULT	ACTION TO TAKE
KE1	SERVICE CODE 12/412: CHECK FOR RPM DROP		
	<p>Service Code 12/412 indicates that during Engine Running Self-Test, engine rpm could not be controlled within the Self-Test upper limit band.</p> <p>Possible causes are:</p> <ul style="list-style-type: none"> — Open or shorted circuit — Throttle linkage binding — Improper idle set — Throttle body/ISC solenoid contamination — Items external to Idle Speed Control system that could affect engine rpm. — Faulty ISC solenoid — Faulty processor <ul style="list-style-type: none"> • Key off. • Connect engine tachometer. • Start engine. • Disconnect ISC harness connector. • Does rpm drop or stall? 	<p>Yes</p> <p>No</p>	<p>GO to KE2 .</p> <p>GO to KE3 .</p>
KE2	CHECK FOR EGR CODES		
	<ul style="list-style-type: none"> • Are Service Codes 31/327, 32/326/328, 33/332 or 34/336/334 present? 	<p>Yes</p> <p>No</p>	<p>RECONNECT ISC solenoid. GO to TESTING PROCEDURES/QUICK TEST AND DIAGNOSTIC AIDS/QUICK TEST CODES AND DISCRPTIONS for appropriate Pinpoint Test.</p> <p>GO to KE3 .</p>
KE3	CHECK FOR OTHER EEC CODES		
	<ul style="list-style-type: none"> • Are Service Codes 22/126, 41/172, 42/173, 91/136 or 92/137 present? 	<p>Yes</p> <p>No</p>	<p>RECONNECT ISC solenoid. GO to Quick TESTING PROCEDURES/QUICK TEST AND DIAGNOSTIC AIDS/QUICK TEST CODES AND DISCRPTIONS for appropriate Pinpoint Test.</p> <p>GO to KE4 .</p>

EEC-IV Pinpoint Test

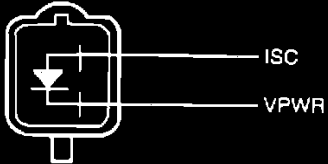
TEST STEP		RESULT	ACTION TO TAKE
KE4	MEASURE ISC SOLENOID RESISTANCE		
<ul style="list-style-type: none"> • Key off. • ISC solenoid disconnected. • Measure solenoid resistance. <p>NOTE: Due to diode in solenoid, place DVOM (+) lead on VPWR pin and (-) lead on ISC pin</p> <ul style="list-style-type: none"> • Is resistance between 7.0 and 13.0 ohms?  <p style="text-align: center;">ISC SOLENOID CONNECTOR</p>		<p>Yes</p> <p>No</p>	<p>GO to KE5 .</p> <p>REPLACE ISC solenoid. RERUN Quick Test. (Refer to TESTING PROCEDURES/QUICK TEST AND DIAGNOSTIC AIDS/ DETAILED QUICK TEST PROCEDURES/KEY ON ENGINE OFF SELF TEST for quick test procedures).</p>
KE5	CHECK FOR INTERNAL SHORT TO ISC SOLENOID CASE		
<ul style="list-style-type: none"> • Key off. • ISC solenoid disconnected. • Measure resistance from either ISC solenoid pin to ISC housing. • Is resistance greater than 10,000 ohms? 		<p>Yes</p> <p>No</p>	<p>GO to KE6 .</p> <p>REPLACE ISC solenoid. RERUN Quick Test. (Refer to TESTING PROCEDURES/QUICK TEST AND DIAGNOSTIC AIDS/ DETAILED QUICK TEST PROCEDURES/KEY ON ENGINE OFF SELF TEST for quick test procedures).</p>
KE6	CHECK VPWR CIRCUIT VOLTAGE		
<ul style="list-style-type: none"> • Key on, engine off. • ISC solenoid disconnected. • Measure voltage between VPWR circuit at the ISC solenoid vehicle harness connector and battery ground. • Is voltage greater than 10.5 volts? 		<p>Yes</p> <p>No</p>	<p>GO to KE7 .</p> <p>SERVICE open circuit. RERUN Quick Test. (Refer to TESTING PROCEDURES/QUICK TEST AND DIAGNOSTIC AIDS/ DETAILED QUICK TEST PROCEDURES/KEY ON ENGINE OFF SELF TEST for quick test procedures).</p>

EEC-IV Pinpoint Test

TEST STEP		RESULT	ACTION TO TAKE
KE7	CHECK ISC CIRCUIT CONTINUITY		
<ul style="list-style-type: none"> • Key off. • ISC solenoid disconnected. • Disconnect processor and inspect both 60 pin connectors for damaged or pushed out pins, corrosion, loose wires, etc. Service as necessary. • Install breakout box, leave processor disconnected. • Measure resistance between Test Pin 21 at the breakout box and ISC circuit at ISC solenoid vehicle harness connector. • Is resistance less than 5 ohms? 		Yes	GO to KE8 .
		No	SERVICE open circuit. REMOVE breakout box. RECONNECT all components. RERUN Quick Test. (Refer to TESTING PROCEDURES/ QUICK TEST AND DIAGNOSTIC AIDS/ DETAILED QUICK TEST PROCEDURES/ KEY ON ENGINE OFF SELF TEST for quick test procedures.)
KE8	CHECK ISC CIRCUIT FOR SHORT TO GROUND		
<ul style="list-style-type: none"> • Key off. • Breakout box installed, processor disconnected. • ISC solenoid disconnected. • Measure resistance between Test Pin 21 and Test Pins 40, 46 and 60 at the breakout box. • Is each resistance greater than 10,000 ohms? 		Yes	GO to KE9 .
		No	SERVICE short circuit. REMOVE breakout box. RECONNECT all components. RERUN Quick Test. (Refer to TESTING PROCEDURES/ QUICK TEST AND DIAGNOSTIC AIDS/ DETAILED QUICK TEST PROCEDURES/ KEY ON ENGINE OFF SELF TEST for quick test procedures.)
KE9	CHECK ISC CIRCUIT FOR SHORT TO POWER		
<ul style="list-style-type: none"> • Key off. • Breakout box installed, processor disconnected. • ISC solenoid disconnected. • Measure resistance between Test Pin 37 and Test Pin 21 at the breakout box. • Is resistance greater than 10,000 ohms? 		Yes	GO to KE10 .
		No	SERVICE short circuit. REMOVE breakout box. RECONNECT all components. RERUN Quick Test. (Refer to TESTING PROCEDURES/ QUICK TEST AND DIAGNOSTIC AIDS/ DETAILED QUICK TEST PROCEDURES/ KEY ON ENGINE OFF SELF TEST for quick test procedures.) If code or symptom is still present, REPLACE processor.

EEC-IV Pinpoint Test

TEST STEP		RESULT	ACTION TO TAKE
KE10	CHECK FOR ISC SIGNAL FROM THE PROCESSOR		
	<ul style="list-style-type: none"> • Key off. • Breakout box installed. • Reconnect processor to breakout box. • Reconnect ISC solenoid. • Connect DVOM between Test Pin 21 and Test Pin 40 at the breakout box. • Start engine. • Slowly increase rpm to 3000 rpm. • Is voltage between 3.0 and 11.5 volts? 	<p>Yes</p> <p>No</p>	<p>GO to KE11 .</p> <p>REPLACE processor. REMOVE breakout box. RERUN Quick Test. (Refer to TESTING PROCEDURES/ QUICK TEST AND DIAGNOSTIC AIDS/ DETAILED QUICK TEST PROCEDURES/ KEY ON ENGINE OFF SELF TEST for quick test procedures.)</p>
KE11	CHECK BASE IDLE		
	<ul style="list-style-type: none"> • Is idle speed within specification? (Refer to SPECIFICATIONS/MECHANICAL SPECIFICATION /IDLE SPEED). 	<p>Yes</p> <p>No</p>	<p>REMOVE ISC solenoid and INSPECT for contamination. CLEAN as necessary. (Refer to COMPONENT REPLACEMENT AND REPAIR PROCEDURES/IDLE SPEED CONTROL BYPASS AIR (ISC-BPA) VALVE) RERUN Quick Test. (Refer to TESTING PROCEDURES/ QUICK TEST AND DIAGNOSTIC AIDS/ DETAILED QUICK TEST PROCEDURES/ KEY ON ENGINE OFF SELF TEST for quick test procedures.) If code/symptom is present, REPLACE ISC solenoid.</p> <p>RESET idle to specification. Refer to ADJUSTMENT PROCEDURES/ IDLE SPEED for Idle set procedure. RERUN Quick Test. (Refer to TESTING PROCEDURES/ QUICK TEST AND DIAGNOSTIC AIDS/ DETAILED QUICK TEST PROCEDURES/ KEY ON ENGINE OFF SELF TEST for quick test procedures.) If UNABLE to RESET idle to specification, GO to KE12.</p>

EEC-IV Pinpoint Test

TEST STEP		RESULT	ACTION TO TAKE
KE12	CHECK FOR PROBLEMS AFFECTING PROPER ENGINE SPEED	Yes	REMOVE ISC solenoid and INSPECT for contamination. CLEAN as necessary. (Refer to COMPONENT REPLACEMENT AND REPAIR PROCEDURES/IDLE SPEED CONTROL BYPASS AIR [ISC-BPA] VALVE) RERUN Quick Test. (Refer to TESTING PROCEDURES/ QUICK TEST AND DIAGNOSTIC AIDS/ DETAILED QUICK TEST PROCEDURES/ KEY ON ENGINE OFF SELF TEST for quick test procedures.) If code/symptom is present, REPLACE ISC solenoid.
		No	SERVICE as necessary. REMOVE breakout box. RECONNECT processor. RERUN Quick Test. (Refer to TESTING PROCEDURES/ QUICK TEST AND DIAGNOSTIC AIDS/ DETAILED QUICK TEST PROCEDURES/ KEY ON ENGINE OFF SELF TEST for quick test procedures.)
KE15	SERVICE CODE 13/411: Service Code 13/411 indicates that during Engine Running Self-Test, Engine rpm could not be controlled within the Self-Test lower limit band. Possible causes are: — Improper idle set. — Vacuum leaks. — Throttle linkage binding. — Throttle plates open. — Improper ignition timing (TFI vehicles only). — Throttle body/ISC solenoid contamination. — ISC circuit short to ground. — Faulty ISC solenoid. • Is idle speed within specification? (Refer to SPECIFICATIONS/MECHANICAL SPECIFICATIONS/IDLE SPEED).	Yes	REMOVE ISC solenoid and INSPECT for contamination. CLEAN as necessary. (Refer to COMPONENT REPLACEMENT AND REPAIR PROCEDURES/IDLE SPEED CONTROL BYPASS AIR (ISC-BPA) VALVE) RERUN Quick Test. (Refer to TESTING PROCEDURES/ QUICK TEST AND DIAGNOSTIC AIDS/ DETAILED QUICK TEST PROCEDURES/ KEY ON ENGINE OFF SELF TEST for quick test procedures.) If code/symptom is present, REPLACE ISC solenoid.
		No	RESET idle to specification. REFER to ADJUSTMENT PROCEDURES/IDLE SPEED for idle set procedure. RERUN Quick Test. (Refer to TESTING PROCEDURES/ QUICK TEST AND DIAGNOSTIC AIDS/ DETAILED QUICK TEST PROCEDURES/ KEY ON ENGINE OFF SELF TEST for quick test procedures.) If UNABLE to RESET idle to specification, GO to KE16.

EEC-IV Pinpoint Test

TEST STEP		RESULT	ACTION TO TAKE
KE16	CHECK FOR CONDITIONS AFFECTING IDLE		
<ul style="list-style-type: none"> • Check engine vacuum hoses for leaks. Refer to VECI decal. • Check throttle linkage and/or speed control linkage for binding. • Check that throttle plates are fully closed. • Check for induction system leaks. (ex. ISC solenoid to throttle body gasket.) • Check throttle body for contamination. • Verify base timing is to specification (TFI vehicles only). Refer to VECI decal. • Verify that CANP solenoid(s) is not stuck open (if equipped). • Are all the above checks OK? 		Yes No	GO to KE17 . SERVICE as necessary. RERUN Quick Test. (Refer to TESTING PROCEDURES/QUICK TEST AND DIAGNOSTIC AIDS/DETAILED QUICK TEST AND DIAGNOSTIC AIDS/DETAILED QUICK TEST PROCEDURES/ KEY IN ENGINE OFF SELF TEST for quick test procedures)
KE17	CHECK FOR INTERNAL SHORT TO ISC SOLENOID CASE		
<ul style="list-style-type: none"> • Key off. • Disconnect ISC solenoid. • Measure resistance from either ISC solenoid pin to ISC housing. • Is resistance greater than 10,000 ohms? 		Yes No	GO to KE18 . REPLACE ISC solenoid. RERUN Quick Test. (Refer to TESTING PROCEDURES/QUICK TEST AND DIAGNOSTIC AIDS/DETAILED QUICK TEST PROCEDURES/ KEY IN ENGINE OFF SELF TEST for quick test procedures)
KE18	CHECK ISC CIRCUIT FOR SHORT TO GROUND		
<ul style="list-style-type: none"> • Key off. • ISC solenoid disconnected. • Disconnect the processor 60 pin connector. Inspect for damaged or pushed out pins, corrosion, loose wires, etc. Service as necessary. • Install breakout box, leave processor disconnected. • Measure resistance between Test Pin 21 and Test Pins 40, 46 and 60 at the breakout box. • Are all resistances greater than 10,000 ohms? 		Yes No	GO to KE19 . SERVICE short circuit. REMOVE breakout box. RECONNECT all components. RERUN Quick Test. (Refer to TESTING PROCEDURES/QUICK TEST AND DIAGNOSTIC AIDS/DETAILED QUICK TEST PROCEDURES/ KEY IN ENGINE OFF SELF TEST for quick test procedures)

EEC-IV Pinpoint Test

TEST STEP		RESULT	ACTION TO TAKE
KE19	CHECK PROCESSOR OUTPUT	Yes	REMOVE ISC solenoid and INSPECT for contamination. CLEAN as necessary (refer to COMPONENT REPLACEMENT AND REPAIR PROCEDURES/ IDLE SPEED CONTROL BYPASS AIR [ISC-BPA] VALVE). RERUN Quick Test. If code/ symptom is present, REPLACE ISC solenoid
	<ul style="list-style-type: none"> • Key off. • Breakout box installed. • Reconnect processor to breakout box. • Reconnect ISC solenoid. • DVOM on 20 volt scale. • Connect DVOM between Test Pin 21 and Test Pin 40. • Start engine. • Slowly increase and decrease rpm. • Does DVOM voltage decrease when rpm is increased? 	No	REPLACE processor. REMOVE breakout box. RERUN Quick Test. (Refer to TESTING PROCEDURES/QUICK TEST AND DIAGNOSTIC AIDS/DETAILED QUICK TEST PROCEDURES/ KEY ON ENGINE OFF SELF TEST for quick test procedures)

EEC-IV Pinpoint Test

Pinpoint Test Schematic

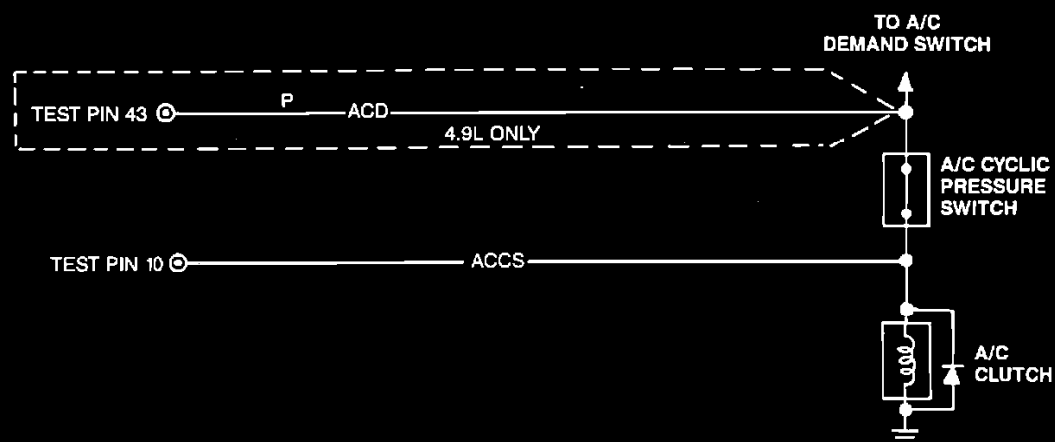

Test Pin 10	ACCS
Application	Wire Color
All	BK/Y

EEC-IV Pinpoint Test

Note

You should enter this Pinpoint Test only when directed here from Quick Test or Pinpoint Test TA.

Remember

To prevent the replacement of good components, be aware that the following non-EEC areas may be at fault:

- Refrigerant charge
- Ambient temperature less than 45°

This Pinpoint Test is intended to diagnose only the following:

- Harness circuits: WAC, VPWR, GND, POWER-TO-CLUTCH, ACD
- WAC relay (11433 or 13A025) or A/C fan controller (8C619)
- Processor assembly (12A650)

EEC-IV Pinpoint Test

TEST STEP		RESULT	ACTION TO TAKE
KM1	NO A/C: CHECK FOR VOLTAGE AT A/C CLUTCH		
<p>NOTE: Before proceeding with "NO A/C" diagnostics, verify integrity of related fuses in fuse panel.</p> <ul style="list-style-type: none"> • Key off. • Disconnect A/C clutch. • A/C demand switch to A/C. • Start engine, wait 10 seconds. • Measure voltage between the power side of the A/C clutch vehicle harness connector and battery negative post. • Is voltage greater than 10.5 volts? 		Yes	EEC-IV system OK. Refer to check for poor ground, open circuit in clutch, mechanical problems, etc.
		No	GO to KM2 .
KM2	CHECK POWER-TO-CLUTCH CIRCUIT CONTINUITY		
<ul style="list-style-type: none"> • Key off. • A/C clutch disconnected. • Disconnect WAC relay or A/C fan controller. • Measure resistance between power side of the A/C clutch vehicle harness connector and POWER-TO-CLUTCH pin at the WAC relay or A/C fan controller vehicle harness connector. • Is resistance less than 5.0 ohms? 		Yes	RECONNECT A/C clutch. GO to KM3 .
		No	SERVICE open circuit. RECONNECT all components. RE-EVALUATE symptom.

EEC-IV Pinpoint Test

TEST STEP		RESULT	ACTION TO TAKE
KM3	CHECK FOR POWER ON A/C DEMAND CIRCUIT		
	<ul style="list-style-type: none"> • Key on, engine off. • WAC relay or A/C fan controller disconnected. • A/C demand switch to A/C. • Measure voltage between A/C demand input pin at WAC relay or A/C fan controller vehicle harness connector and chassis ground. • Is voltage greater than 10.5 volts? 	<p>Yes</p> <p>No</p>	<p>GO to KM5.</p> <p>VERIFY operation of A/C clutch cyclic pressure switch and A/C demand switch. REFER to HEATING, VENTILATION, AND AIR CONDITIONING, If OK, SERVICE open circuit. RECONNECT all components. RE-EVALUATE symptom.</p>
KM4	CHECK CONTINUITY BETWEEN WAC RELAY AND A/C RELAY		
	<ul style="list-style-type: none"> • Key off. • WAC relay disconnected. • Disconnect A/C relay. • Measure resistance between the A/C relay output to the WAC relay at the A/C relay vehicle harness connector and the A/C relay input at the WAC relay vehicle harness connector. • Is resistance less than 5.0 ohms? 	<p>Yes</p> <p>No</p>	<p>RECONNECT WAC relay. REFER to HEATING, VENTILATION, AND AIR CONDITIONING, to check for proper input to A/C relay from BATT(+), IGN RUN and A/C demand circuits; proper A/C relay operation, etc.</p> <p>SERVICE open circuit. RECONNECT WAC relay and A/C relay.</p>

EEC-IV Pinpoint Test

TEST STEP		RESULT	ACTION TO TAKE
KM5	CHECK WAC CIRCUIT FOR SHORT TO GROUND		
	<ul style="list-style-type: none"> • Key off. • WAC relay or A/C fan controller disconnected. • Disconnect processor 60 pin connector. Inspect for damaged or pushed out pins, corrosion, loose wires, etc. Service as necessary. Leave processor disconnected. • Measure resistance between WAC circuit at the WAC relay or A/C fan controller harness connector and chassis ground. • Is resistance greater than 10,000 ohms? 	<p>Yes ▶</p> <p>No ▶</p>	<p>GO to KM6.</p> <p>SERVICE short circuit. RECONNECT all components. RE-EVALUATE symptom.</p>
KM6	CHECK FOR VOLTAGE AT ACC/S INPUT TO PROCESSOR		
	<ul style="list-style-type: none"> • Key off. • WAC relay or A/C fan controller disconnected. • Processor disconnected. • Install breakout box, leave processor disconnected. • Key on, engine off. • A/C demand switch to A/C. • Measure voltage between Test Pin 10 and Test Pin 40 at the breakout box. • Is voltage greater than 10.5 volts? 	<p>Yes ▶</p> <p>No ▶</p>	<p>GO to KM9.</p> <p>SERVICE open in ACC/S circuit. REMOVE breakout box. RECONNECT all components. RE-EVALUATE symptom.</p>
KM7	CHECK FOR GROUND TO A/C FAN CONTROLLER		
	<ul style="list-style-type: none"> • Key off. • A/C fan controller disconnected. • Breakout box installed, processor disconnected. • Measure resistance between ground circuit at A/C fan controller vehicle harness connector and chassis ground. • Is resistance less than 5.0 ohms? 	<p>Yes ▶</p> <p>No ▶</p>	<p>GO to KM8.</p> <p>SERVICE open circuit. REMOVE breakout box. RECONNECT all components. RE-EVALUATE symptom.</p>

EEC-IV Pinpoint Test

TEST STEP		RESULT	ACTION TO TAKE
KM8	CHECK FOR VOLTAGE TO A/C FAN CONTROLLER		
<ul style="list-style-type: none"> • Key on. • A/C fan controller disconnected. • Breakout box installed, processor disconnected. • Measure voltage between ignition switch RUN circuit at the A/C fan controller vehicle harness connector and chassis ground. • Measure voltage between BATT(+) circuit at the A/C fan controller vehicle harness connector and chassis ground. • Are both voltages greater than 10.5 volts? 		<p>Yes ▶</p> <p>No ▶</p>	<p>GO to KM9 .</p> <p>SERVICE open circuit. REMOVE breakout box. RECONNECT all components. RE-EVALUATE symptom.</p>
KM9	CHECK WAC RELAY, A/C FAN CONTROLLER		
<ul style="list-style-type: none"> • Key off. • Breakout box installed, processor disconnected. • Reconnect WAC relay or A/C fan controller. • Disconnect A/C clutch. • Key on, engine off. • A/C demand switch to A/C. • Measure voltage between the power side of the A/C clutch vehicle harness connector and the battery negative post. • Is voltage greater than 10.5 volts? 		<p>Yes ▶</p> <p>No ▶</p>	<p>REPLACE processor. RECONNECT A/C clutch. RE-EVALUATE symptom.</p> <p>REPLACE WAC relay or A/C fan controller. REMOVE breakout box. RECONNECT all compounds. RE-EVALUATE symptom.</p>

EEC-IV Pinpoint Test

TEST STEP		RESULT	ACTION TO TAKE
KM15	NO A/C CUTOFF AT WOT: ENTER OUTPUT STATE CHECK (Refer to TESTING PROCEDURES/QUICK TEST AND DIAGNOSTIC AIDS/DETAILED QUICK TEST PROCEDURES/KEY ON ENGINE OFF SELF TEST for quick test procedures)		
<p>NOTE: Do not use STAR tester for this Step, use VOM/DVOM.</p> <ul style="list-style-type: none"> • Key off, wait 10 seconds. • Disconnect electrical connector on the Speed Control servo; if equipped. • Connect DVOM negative test lead to STO at the Self-Test connector and positive test lead to battery positive post. • Jumper STI to SIGNAL RETURN at the Self-Test connector. • Perform Key On Engine Off Self-Test until the completion of the Continuous Memory Codes. (Refer to TESTING PROCEDURES/QUICK TEST AND DIAGNOSTIC AIDS/DETAILED QUICK TEST PROCEDURES/KEY ON ENGINE OFF SELF TEST for test procedures). • DVOM will indicate less than 1.0 volt when test complete. • Depress and release the throttle. • Does voltage increase to greater than 10.5 volts? 		<p>Yes</p> <p>No</p>	<p>REMAIN in Output State Check.</p> <p>GO to KM16.</p> <p>DEPRESS throttle to WOT and RELEASE. If STO voltage does not go high, leave equipment hooked up and GO to Pinpoint Test QC, Step QC2</p>
KM16	CHECK FOR VPWR TO RELAY		
<ul style="list-style-type: none"> • Still in Output State Check. • Disconnect harness from WAC relay. • Measure voltage between VPWR circuit at the WAC relay vehicle harness connector and chassis ground. • Is voltage greater than 10.5 volts? 		<p>Yes</p> <p>No</p>	<p>GO to KM17.</p> <p>SERVICE open in VPWR circuit between power relay and WAC relay.</p> <p>RECONNECT all components and REMOVE jumper. RE-EVALUATE symptom.</p>

EEC-IV Pinpoint Test

TEST STEP	RESULT	ACTION TO TAKE
KM17 CHECK FOR WAC CYCLING <ul style="list-style-type: none"> • Still in Output State Check. • Reconnect WAC relay. • DVOM on 20 volt scale. • Connect DVOM positive test lead to the VPWR circuit and the negative test lead to the WAC circuit at the WAC relay vehicle harness connector. • While observing DVOM, depress and release off) throttle several times (to cycle output on and • Does voltage cycle high and low? 	Yes No	REPLACE WAC relay. REMOVE jumper. RE-EVALUATE symptom. REMOVE jumper. RECONNECT Speed Control servo. GO to KM18 .
KM18 CHECK RESISTANCE OF WAC RELAY COIL <ul style="list-style-type: none"> • Key off. • Disconnect WAC relay. • Measure resistance between the WAC pin and VPWR pin on the WAC relay. • Is resistance between 40 and 100 ohms? 	Yes No	GO to KM19 . REPLACE WAC relay. RE-EVALUATE symptom.
KM19 CHECK WAC CIRCUIT CONTINUITY <ul style="list-style-type: none"> • Key off. • Disconnect processor 60 pin connector. Inspect for damaged or pushed out pins, corrosion, loose wires, etc. Service as necessary. • Install breakout box, leave processor disconnected. • WAC relay disconnected. • Measure resistance between Test Pin 54 at the breakout box and WAC circuit at the WAC relay vehicle harness connector. • Is resistance less than 5.0 ohms? 	Yes No	GO to KM20 . SERVICE open circuit. REMOVE breakout box. RECONNECT all components. RE-EVALUATE symptom.

EEC-IV Pinpoint Test

TEST STEP		RESULT	ACTION TO TAKE
KM20	CHECK WAC CIRCUIT FOR SHORT TO POWER		
	<ul style="list-style-type: none"> • Key off. • Breakout box installed, processor disconnected. • WAC relay disconnected. • Measure resistance between Test Pin 54 and Test Pins 37 and 57 at the breakout box. • Are both resistances greater than 10,000 ohms? 	<p>Yes</p> <p>No</p>	<p>REPLACE processor. RECONNECT WAC relay. REEVALUATE symptom.</p> <p>SERVICE short circuit. REMOVE breakout box. RECONNECT all components. RE-EVALUATE symptom. IF symptom is still present, REPLACE processor.</p>
KM21	CHECK FOR WAC CYCLING		
	<ul style="list-style-type: none"> • Still in Output State Check. • Disconnect A/C fan controller. • Connect DVOM positive test lead to the Ignition Run circuit and the negative test lead to the WAC circuit at the A/C fan controller vehicle harness connector. • While observing DVOM, depress and release throttle several times (to cycle output on and off). • Does voltage cycle high and low (about 1 volt change)? 	<p>Yes</p> <p>No</p>	<p>REPLACE A/C fan controller. REMOVE jumper. RECONNECT Speed Control servo. RE-EVALUATE symptom.</p> <p>REMOVE jumper. RECONNECT Speed Control servo. GO to KM22.</p>
KM22	CHECK WAC CIRCUIT CONTINUITY		
	<ul style="list-style-type: none"> • Key off. • Disconnect processor 60 pin connector. Inspect for damaged or pushed out pins, corrosion, loose wires, etc. Service as necessary. • Install breakout box, leave processor disconnected. • A/C fan controller disconnected. • Measure resistance between Test Pin 54 at the breakout box and WAC circuit at the WAC relay vehicle harness connector. • Is resistance less than 5.0 ohms? 	<p>Yes</p> <p>No</p>	<p>GO to KM23.</p> <p>SERVICE open circuit. REMOVE breakout box. RECONNECT processor and A/C fan controller. RE-EVALUATE symptom.</p>

EEC-IV Pinpoint Test

TEST STEP		RESULT	ACTION TO TAKE
KM23	CHECK WAC CIRCUIT FOR SHORT TO POWER		
	<ul style="list-style-type: none"> • Key off. • Breakout box installed, processor disconnected. • A/C fan controller disconnected. • Measure resistance between Test Pin 54 and Test Pins 37 and 57 at the breakout box. • Are both resistances greater than 10,000 ohms? 	<p>Yes</p> <p>No</p>	<p>REPLACE processor. RECONNECT A/C fan controller. RE-EVALUATE symptom.</p> <p>SERVICE short circuit. REMOVE breakout box. RECONNECT processor and A/C fan controller. RE-EVALUATE symptom. If symptom is still present, REPLACE processor.</p>
KM30	CYCLE A/C DEMAND SWITCH		
	<ul style="list-style-type: none"> • Key off. • Disconnect processor 60 pin connector. Inspect for damaged or pushed out pins, corrosion, loose wires, etc. Service as necessary. • Install breakout box, leave processor disconnected. • DVOM on 20 volt scale. • Key on, engine off. • Connect DVOM positive test lead to Test Pin 43 and negative test lead to Test Pin 40. • Does voltage cycle high and low when A/C demand switch is cycled? 	<p>Yes</p> <p>No</p>	<p>GO to KM44.</p> <p>GO to KM31.</p>
KM31	CHECK ACD CIRCUIT CONTINUITY		
	<ul style="list-style-type: none"> • Key off. • Breakout box installed, processor disconnected. • Measure resistance between Test Pin 43 at the breakout box and A/C demand switch. • Is resistance greater than 5 ohms? 	<p>Yes</p> <p>No</p>	<p>SERVICE open in ACD circuit REMOVE breakout box. RECONNECT processor. RERUN Quick Test. (Refer to TESTING PROCEDURES/QUICK TEST AND DIAGNOSTIC AIDS/DETAILED QUICK TEST PROCEDURES/KEY ON ENGINE OFF SELF TEST for quick test procedures.)</p> <p>EEC-IV system OK. REMOVE breakout box. RECONNECT processor. REFER to HEATING, VENTILATION, AND AIR CONDITIONING.</p>

EEC-IV Pinpoint Test

TEST STEP	RESULT	ACTION TO TAKE
<p>KM35 CHECK A/C CIRCUIT FOR SHORT TO POWER</p> <ul style="list-style-type: none"> • Key off. • Disconnect processor 60 pin connector. Inspect for damaged or pushed out pins, corrosion, loose wires, etc. Service as necessary. • Install breakout box, leave processor disconnected. • Disconnect WAC relay (except 4.9L) <ul style="list-style-type: none"> • A/C demand switch "OFF". • Key on, engine off. • Measure voltage between Test Pin 43 at the breakout box and chassis ground. • Is voltage less than 1.0 volt? 	<p>Yes</p> <p>No</p>	<p>EEC-IV system OK. REMOVE breakout box. RECONNECT all components. REFER to HEATING, VENTILATION, AND AIR CONDITIONING.</p> <p>VERIFY operation of A/C demand switch. IF OK, SERVICE short circuit. REMOVE breakout box. RECONNECT all components. RE-EVALUATE symptom.</p>
<p>KM40 CHECK A/C INPUT</p> <p>Service Code 79/539 indicates that the ACC/S input to the processor was high during Self-Test.</p> <p>NOTE: Before entering this test, verify A/C selector is off (and shift selector is in PARK for E40D vehicles). If A/C was on, rerun Quick Test. If code 67 or 79/539 is present, continue with this test. (Refer to TESTING PROCEDURES/QUICK TEST AND DIAGNOSTIC AIDS/DETAILED QUICK TEST PROCEDURES/KEY ON ENGINE OFF SELF TEST for quick test procedures.)</p> <ul style="list-style-type: none"> • Disconnect processor 60 pin connector. Inspect for damaged or pushed out pins, corrosion, loose wires, etc. Service as necessary. • Install breakout box, leave processor disconnected. • Key on, engine off. • Measure voltage between Test Pin 10 at the breakout box and chassis ground. • Is voltage greater than 1.0 volt? 	<p>Yes</p> <p>No</p>	<p>SERVICE short to power in A/C circuit. REMOVE breakout box. RECONNECT all components. RERUN Quick Test.</p> <p>For trucks with 2 digit codes and E40D transmission: GO to KM41.</p> <p>For all others: REPLACE processor. REMOVE breakout box. RECONNECT all components. RERUN Quick Test. (Refer to TESTING PROCEDURES/QUICK TEST AND DIAGNOSTIC AIDS/DETAILED QUICK TEST PROCEDURES/KEY ON ENGINE OFF SELF TEST for quick test procedures).</p>

EEC-IV Pinpoint Test

TEST STEP		RESULT	ACTION TO TAKE
KM41	CHECK FOR SHORT TO POWER IN PROCESSOR	Yes	REPLACE processor. RECONNECT A/C clutch. RERUN Quick Test. (Refer to TESTING PROCEDURES/QUICK TEST AND DIAGNOSTIC AIDS/DETAILED QUICK TEST PROCEDURES/KEY ON ENGINE OFF SELF TEST for quick test procedures)
	<ul style="list-style-type: none"> • Key off. • Breakout box installed. • Connect processor to breakout box. • Disconnect A/C clutch. • Key on, engine off. • Measure voltage between Test Pin 10 and Test Pin 40 at the breakout box. • Is voltage greater than 1.0 volt? 	No	GO to TC1.
KM43	CHECK A/C INPUT CIRCUITRY	Yes	The processor is receiving and recognizing the A/C input on Pin 10. RETURN to DIAGNOSTIC ROUTINES for other possible causes of a low idle.
	<p>NOTE: A low idle with A/C on could be the result of the processor not receiving, or recognizing, the A/C input on Pin 10.</p> <ul style="list-style-type: none"> • A/C demand switch to A/C. • Perform Key On Engine Off Self-Test. TESTING PROCEDURES/QUICK TEST AND DIAGNOSTIC AIDS/DETAILED QUICK TEST PROCEDURES/KEY ON ENGINE OFF SELF TEST for quick test procedures). • Is code 67 or 79/539 present? 	No	A/C demand switch off. GO to KM44.
KM44	CHECK A/C INPUT CIRCUIT	Yes	REPLACE processor. REMOVE breakout box. RECONNECT all components. RERUN Quick Test. (Refer to TESTING PROCEDURES/QUICK TEST AND DIAGNOSTIC AIDS/DETAILED QUICK TEST PROCEDURES/KEY ON ENGINE OFF SELF TEST for quick test procedures)
	<ul style="list-style-type: none"> • Key off. • Disconnect processor 60 pin connector. Inspect for damaged or pushed out pins, corrosion, loose wires, etc. Service as necessary. • Install breakout box, leave processor disconnected. • Key on, engine off. • A/C on. • Measure voltage between Test Pin 10 and Test Pin 40. • Is voltage greater than 10.5 volts? 	No	SERVICE open in A/C circuit. REMOVE breakout box. RECONNECT all components. RERUN Quick Test. (Refer to TESTING PROCEDURES/QUICK TEST AND DIAGNOSTIC AIDS/DETAILED QUICK TEST PROCEDURES/KEY ON ENGINE OFF SELF TEST for quick test procedures).

EEC-IV Pinpoint Test

Note

You should enter this Pinpoint Test only when you have been directed here from Quick Test.

Remember

To prevent the replacement of good components, be aware that the following non-EEC areas may be at fault:

- Operator did not perform a brief WOT after Dynamic Response code.
- Mechanical engine problems; engine did not achieve greater than 2000 rpm.

This Pinpoint Test is intended to diagnose only the following:

- Throttle movement (greater than 3/4 throttle)
- Rpm increase (greater than 2000 rpm)

Pinpoint Test Schematic

OPERATOR PERFORMS BRIEF WOT

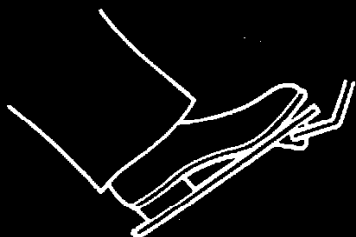

RPM INCREASE
GREATER THAN 2000 RPM

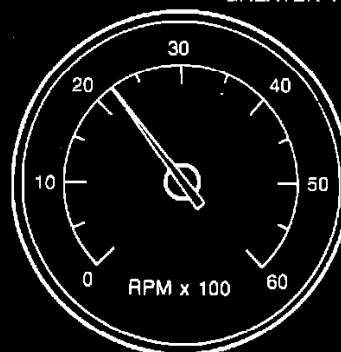

EEC-IV Pinpoint Test

TEST STEP		RESULT	ACTION TO TAKE
M1	SERVICE CODE 77/538: SYSTEM FAILED TO RECOGNIZE BRIEF WOT		
<p>NOTE: A brief snap of the throttle may not be sufficient to pass this test. Be sure to go to WOT and return.</p> <ul style="list-style-type: none"> • Rerun Engine Running Self-Test. (Refer to TESTING PROCEDURES/QUICK TEST AND DIAGNOSTIC AIDS/DETAILED QUICK TEST PROCEDURES/KEY ON ENGINE RUNNING SELF TEST for self test procedures) Be sure operator is familiar with the Engine Running format which proceeds as follows: <ul style="list-style-type: none"> — Activate Self-Test. — Start engine. — ID Code start of test. — Dynamic Response code 1 (0); perform WOT. — Testing over. — Service code output begins. • Is Code 77 or 538 still present? 		Yes	<p>REPLACE processor. RERUN Quick Test. (Refer to TESTING PROCEDURES/QUICK TEST AND DIAGNOSTIC AIDS/DETAILED QUICK TEST PROCEDURES/ KEY ON ENGINE OFF SELF TEST for quick test procedures).</p>
		No	<p>Dynamic Response Test passed. SERVICE any other service code(s) received as necessary.</p>

EEC-IV Pinpoint Test

Note

You should enter this Pinpoint Test only when you have been directed here from Quick Test or Pinpoint Test QA.

Remember

To prevent the replacement of good components, be aware that the following non-EEC areas may be at fault:

- Fuse, bulb or socket.

This Pinpoint Test is intended to diagnose only the following:

- STO/MIL circuit
- Processor assembly
- Data Communications Link (DCL)

EEC-IV Pinpoint Test

Pinpoint Test Schematic

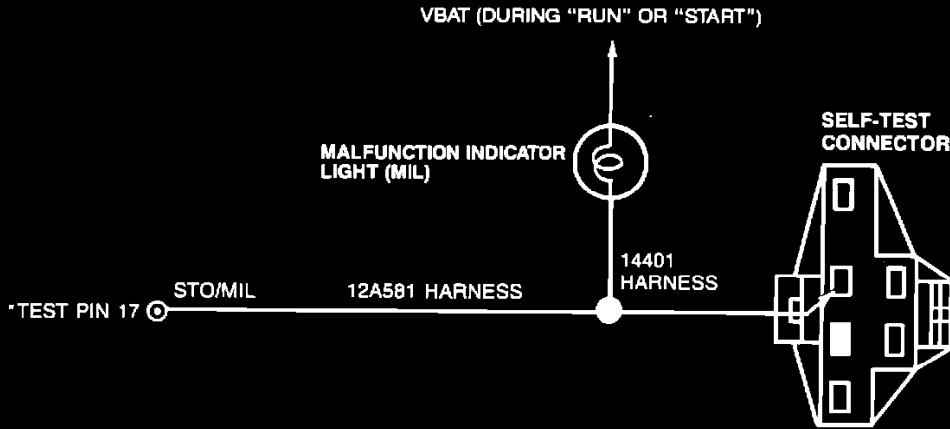

*TEST PINS LOCATED ON BREAKOUT BOX
ALL HARNESS CONNECTORS VIEWED INTO MATING SURFACE

EEC-IV Pinpoint Test

Pinpoint Test Schematic

ALL VEHICLES WITH DATA COMMUNICATION LINKS (DCL)



*TEST PINS LOCATED ON BREAKOUT BOX
HARNESS CONNECTOR VIEWED INTO MATING SURFACE

EEC-IV Pinpoint Test

Test Pin 17		STO/MIL
Application	Wire Color	
2.3L EFI, Ranger	PK/LG	
2.9L EFI, Ranger (49 States)		
3.0L EFI-MA, Ranger		
4.0L EFI-MA, Ranger/Explorer		
4.9L EFI, F-Series/Bronco		
5.0L EFI, F-Series/Bronco		
5.8L EFI, F-Series/Bronco		
7.3L Diesel, F-Series (E40D)	T/R	
7.5L EFI, F-Series		
All Others:		

DATA(+)			DATA(-)		
Application	Pin Number	Wire Colors	Application	Pin Number	Wire Colors
4.0L EFI-MA, Aerostar	28	O/BK	5.8L EFI, F-Series/Bronco	9	PW/LB
4.9L EFI, E-Series	28				
5.0L EFI, E-Series	28				
2.3L EFI, Ranger	28	T/O	4.0L EFI-MA, Aerostar	9	BK-O
3.0L EFI-MA, Ranger					
4.0L EFI-MA, Explorer/Ranger					
4.9L EFI, F-Series/Bronco					
5.0L EFI, F-Series/Bronco					
5.8L EFI, F-Series/Bronco	9	PK/LB	2.3L EFI, Ranger		
3.0L EFI-MA, Ranger					
4.0L EFI-MA, Explorer/Ranger					
4.9L EFI, F-Series/Bronco					
5.0L EFI, F-Series/Bronco			5.0L EFI, F-Series/Bronco		

EEC-IV Pinpoint Test

TEST STEP		RESULT	ACTION TO TAKE
ML1	MALFUNCTION INDICATOR LIGHT (MIL) ALWAYS ON: CHECK STO/MIL CIRCUIT FOR SHORTS TO GROUND	Yes	SERVICE short circuit between Test Pin 17 and Malfunction Indicator Light (MIL), or between Test Pin 17 and the Self-Test Connector. REMOVE breakout box. RECONNECT processor. RERUN Quick Test. (Refer to TESTING PROCEDURES/ QUICK TEST AND DIAGNOSTIC AIDS/ DETAILED QUICK TEST PROCEDURES KEY ON ENGINE OFF SELF TEST for quick test procedures.)
<p>NOTE: If vehicle will not start go to Pinpoint Test A, Step A1.</p> <ul style="list-style-type: none"> • If any Key On Engine Off service codes or Continuous Memory Codes are present, service before proceeding. If no codes are outputted, continue with this Test Step. • Key off. • Disconnect processor 60 pin connector. Inspect for damaged or pushed out pins, corrosion, loose wires, etc. Service as necessary. • Install breakout box, leave processor disconnected. • Measure resistance between Test Pin 17 and Test Pin 40 at the breakout box. • Is resistance less than 5 ohms? 		No	REPLACE processor. REMOVE breakout box. RERUN Quick Test. (Refer to TESTING PROCEDURES/ QUICK TEST AND DIAGNOSTIC AIDS/ DETAILED QUICK TEST PROCEDURES KEY ON ENGINE OFF SELF TEST for quick test procedures.)
ML4	MALFUNCTION INDICATOR LIGHT (MIL) NEVER ON: CHECK FOR VBAT AT MIL FUSE (GROUND SIDE)	Yes	GO to ML6 .
<p>NOTE: If the vehicle will not start, then GO to Pinpoint Test A, Step A1.</p> <ul style="list-style-type: none"> • Key on, engine off. • Measure voltage from battery negative post to "ground" side of the MIL fuse. Refer to either the Owner's Manual or EVTM for the specific location of the MIL fuse. • Is the voltage greater than 10.5 volts? 		No	GO to ML5 .
ML5	CHECK FOR VBAT AT MIL FUSE (VBAT SIDE)	Yes	REPLACE the MIL fuse. VERIFY repair by turning ignition key to the "RUN" position.
<ul style="list-style-type: none"> • Key on, engine off. • Measure voltage from battery negative post to "VBAT" side of the MIL fuse. • Is the voltage greater than 10.5 volts? 		No	Service open in the MIL/VBAT circuit. Verify repair by turning ignition key to the "RUN" position.

EEC-IV Pinpoint Test

TEST STEP		RESULT	ACTION TO TAKE
ML6	CHECK CONTINUITY OF VBAT CIRCUIT: MIL FUSE (GROUND SIDE) TO MIL BULB/SOCKET		
<ul style="list-style-type: none"> • Key off. • Measure resistance between MIL fuse (at the ground side) and the MIL bulb/socket (at the VBAT side). • Is the resistance greater than 10,000 ohms? 		Yes	SERVICE open in the MIL circuit. VERIFY repair by turning ignition key to "RUN" position.
		No	GO to ML7.
ML7	CHECK MIL BULB RESPONSE TO GROUNDING		
<ul style="list-style-type: none"> • Key off. • Attach one end of jumper wire to battery negative post or chassis ground. • Attach other end of jumper wire to ground side of the MIL bulb/socket. • Turn ignition key to "RUN" position. • Is the MIL on? 		Yes	Turn ignition key to the "OFF" position. Remove jumper wire. GO to ML8.
		No	Turn ignition key to the "OFF" position. Remove jumper wire. Replace the MIL bulb/socket. Verify repair by turning the ignition key to the "RUN" position.
ML8	CHECK MIL CIRCUIT CONTINUITY		
<ul style="list-style-type: none"> • Key off. • Disconnect processor 60 pin connector. Inspect for damaged or pushed out pins, corrosion, loose wires, etc. Service as necessary. • Install breakout box, leave processor disconnected. • Measure resistance between Test Pin 17 at the breakout box and the Malfunction Indicator Light (MIL). • Is resistance less than 5 ohms? 		Yes	REPLACE processor. REMOVE breakout box. VERIFY the repair by turning the ignition key to the "RUN" position.
		No	SERVICE open in the MIL circuit. REMOVE breakout box. RECONNECT processor. VERIFY repair by turning the ignition key to the "RUN" position.

EEC-IV Pinpoint Test

TEST STEP		RESULT	ACTION TO TAKE
ML10	MALFUNCTION INDICATOR LIGHT (MIL) INTERMITTENTLY ON: CHECK FOR INTERMITTENT STO SHORT TO GROUND	Yes	SERVICE short to ground. RERUN Quick Test. (Refer to TESTING PROCEDURES / QUICK TEST AND DIAGNOSTIC AIDS/DETAILED QUICK TEST PROCEDURES/ KEY ON ENGINE OFF SELF TEST for quick test procedures).
<p>NOTE: If vehicle will not start go to Pinpoint Test A, Step A1.</p> <p>The Malfunction Indicator Light (MIL) will come ON when there is a Continuous Memory Code present. Service any Continuous Memory Codes before proceeding.</p> <p>If no codes are outputted, continue with this Test Step.</p> <ul style="list-style-type: none"> • Enter Key On Engine Off Continuous Monitor Mode. Refer to Quick Test Appendix. • Observe VOM or STAR LED for indication of a fault while you wiggle, shake or bend a small section of the EEC-IV system harness in the following locations: <ul style="list-style-type: none"> — Harness closest to Self-Test connector to the dash panel — Dash panel to the processor — Dash panel to the Malfunction Indicator light (MIL) • Is a fault indicated? 		No	UNABLE to duplicate fault at this time. If the Malfunction Indicator Light (MIL) flashed on intermittently with pass codes (11-10-11), then testing is complete. The fault occurred over 40/80 warm-up cycles ago. Error codes are not stored in memory beyond 40/80 warm-up cycles.
ML15	MALFUNCTION INDICATOR LIGHT (MIL) FLASHING WITH ERRATIC IDLE: CHECK FOR STI SHORT TO GROUND	Yes	SERVICE short circuit. RECONNECT processor. VERIFY symptom eliminated.
<p>NOTE: Vehicle symptoms indicate that STI is grounded and the vehicle is actually performing Self-Test without a tester installed.</p> <ul style="list-style-type: none"> • Key off. • Disconnect processor 60 pin connector. Inspect for damaged or pushed out pins, corrosion, loose wires, etc. Service as necessary. • Measure resistance between the Self-Test Input (STI) connector and engine block ground. • Is resistance less than 10,000 ohms? 		No	RECONNECT processor. VERIFY symptom. REFER to TESTING PROCEDURES / DIAGNOSTIC ROUTINES for rough idle routines.

EEC-IV Pinpoint Test

TEST STEP		RESULT	ACTION TO TAKE
ML20	"CHECK ENGINE" MESSAGE DISPLAYED		
<p>NOTE: If vehicle is a no start, go to Pinpoint Test A, Step A1.</p> <ul style="list-style-type: none"> • Run Key On Engine Off Self-Test. • Is result 11-10-11 (Pass Codes)? 		<p>Yes</p> <p>No</p>	<p>▶ Go to BODY ELECTRICAL, SAFETY, AND ENTERTAINMENT for DCL diagnosis.</p> <p>▶ Self -Test indicates a fault. (Refer to TESTING PROCEDURES/QUICK TEST AND DIAGNOSTIC AIDS/DETAILED QUICK TEST PROCEDURES/KEY ON ENGINE OFF SELF TEST for quick test procedures.)Start with the first code displayed.</p>
ML25	CONTINUOUS MEMORY CODE 529,"CHECK ENGINE"/"CHECK DCL" MESSAGE DISPLAYED		
<p>Continuous Memory Codes 529 and 533, indicate that a circuit failure has occurred on the Data Communications Link (DCL). These codes can appear alone or in conjunction with one another. The messages "CHECK ENGINE" and/or "CHECK DCL" will also be on.</p> <ul style="list-style-type: none"> — Code 529 indicates an EEC IV processor or Data Communicator Link (DCL) circuit failure. — Code 533 indicates a Data Communication Link to Electronic Instrument Cluster circuit failure. <p>NOTE: If vehicle is a no start, go to Pinpoint Test A, Step A1.</p> <ul style="list-style-type: none"> • Clear Continuous Memory (refer to TESTING PROCEDURES/QUICK TEST AND DIAGNOSTIC AIDS/ DETAILED QUICK TEST PROCEDURES/CONTINUOUS MEMORY CODES for procedures) • Wait five minutes. • Rerun Key On Engine Off Self-Test with a STAR tester or volt/ohmmeter. (Refer to TESTING PROCEDURES/QUICK TEST AND DIAGNOSTIC AIDS/DETAILED QUICK TEST PROCEDURES/KEY ON ENGINE OFF SELF TEST for quick test procedures). • Is result 11-10-111 (Pass Codes)? 		<p>Yes</p> <p>No</p>	<p>▶ GO to BODY ELECTRICAL, SAFETY, AND ENTERTAINMENT for DCL diagnosis.</p> <p>▶ Self-Test indicates a fault. Go to Quick Test. (Refer to TESTING PROCEDURE/QUICK TEST AND DIAGNOSTIC AIDS/DETAILED QUICK TEST PROCEDURES/KEY ON ENGINE OFF SELF TEST for quick test procedures.) Start with the first code displayed.</p>

EEC-IV Pinpoint Test

Note

You should enter this Pinpoint Test only when you have been directed here from Quick Test or IGNITION SYSTEMS.

Remember

To prevent the replacement of good components, be aware that the following non-EEC areas may be at fault:

- TFI
- Ignition coil
- Spark plugs and high tension cables
- Distributor
- Arcing of secondary ignition components

This Pinpoint Test is intended to diagnose only the following:

- Harness circuit: IDM
- Processor assembly (12A650)

EEC-IV Pinpoint Test**NA - Testing Schematic**

*** Updated by TSB #9111B5

Pinpoint Test Schematic

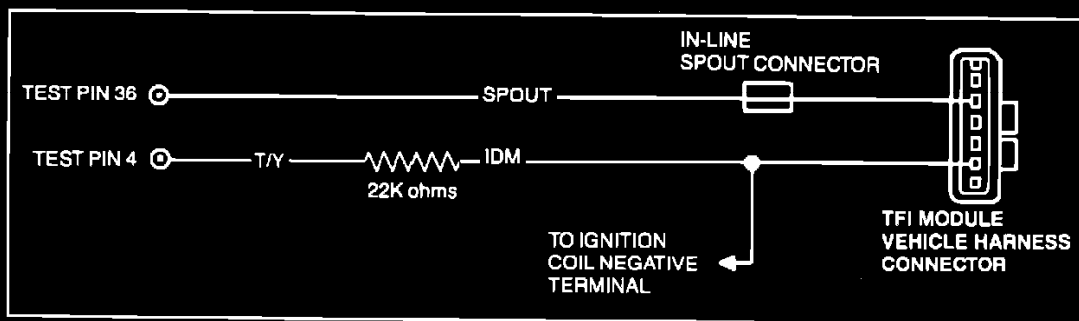

TFI Location

Application	Location
3.0L Aerostar	Radiator Support
7.5L	Left Front Fender
All Others	Distributor

Test Pin 36

Application	Wire Color
2.9L, 3.0L Aerostar, F-Series Truck	PK
All Others	Y/LG

Spout

EEC-IV Pinpoint Test

TEST STEP		RESULT	ACTION TO TAKE
NA1	CONTINUOUS MEMORY CODE 14/211: ERRATIC IGNITION	Yes	SERVICE as necessary. CLEAR Continuous Memory Code 14/211. RERUN Quick Test. (Refer to TESTING PROCEDURES/ QUICK TEST AND DIAGNOSTIC AIDS/ DETAILED QUICK TEST PROCEDURES/ CONTINUOUS MEMORY CODES for code clearing procedures.) (Refer to TESTING PROCEDURES/ QUICK TEST AND DIAGNOSTIC AIDS/ DETAILED QUICK TEST PROCEDURES/ KEY ON ENGINE OFF SELF TEST for quick test procedures.)
	Code 14/211 indicates two successive erratic profile ignition pickup (PIP) pulses occurred, resulting in a possible engine miss or stall. Possible causes: — Loose wires/connectors. — Arcing secondary ignition components (coil, cap, rotor, wires, plugs, etc.). — On-board transmitter (2-way radio).*	No	For vehicles with Computer Control Dwell (Refer to Pinpoint Test Schematic): GO to NA2 . For all others: GO to NA3 .
NA2	CONTINUOUS MEMORY CODE 18/212: CHECK IDM CIRCUIT CONTINUITY	Yes	GO to NA5 .
	Continuous Memory Code 18/212 indicates a loss of IDM input to the processor. Possible causes: — Open harness. — Shorted harness. — TFI module. — Processor. • Key off. • Disconnect processor 60 pin connector. Inspect for damaged or pushed out pins, corrosion, loose wires, etc. Service as necessary. • Install breakout box, leave processor disconnected. • Disconnect TFI module. • Measure resistance between Test Pin 4 at the breakout box and Pin 3 at the TFI vehicle harness connector. • Measure resistance between Pin 5 at the TFI vehicle harness connector and ignition coil harness connector or negative terminal. • Is each resistance less than 5.0 ohms?	No	SERVICE open circuit. REMOVE breakout box. RECONNECT processor. CLEAR Continuous Memory Codes. (Refer to TESTING PROCEDURES/ QUICK TEST AND DIAGNOSTIC AIDS/ DETAILED QUICK TEST PROCEDURES/ CONTINUOUS MEMORY CODES for code clearing procedures.) RECONNECT all components. RERUN Quick Test. (Refer to TESTING PROCEDURES/ QUICK TEST AND DIAGNOSTIC AIDS/ DETAILED QUICK TEST PROCEDURES/ KEY ON ENGINE OFF SELF TEST for quick test procedures.)

EEC-IV Pinpoint Test

TEST STEP		RESULT	ACTION TO TAKE
NA3	CONTINUOUS MEMORY CODE 18/212: CHECK IDM CIRCUIT CONTINUITY		
<p>Continuous Memory Code 18/212 indicates a loss of IDM input to the processor.</p> <p>Possible causes:</p> <ul style="list-style-type: none"> — Open harness. — Shorted harness. — TFI module — Processor. • Key off. • Disconnect processor 60 pin connector. Inspect for damaged or pushed out pins, corrosion, loose wires, etc. Service as necessary. • Install breakout box, leave processor disconnected. • Disconnect E-core ignition coil and TFI module. • Measure resistance between Test Pin 4 at the breakout box and ignition coil harness connector negative terminal. • Is resistance between 20,000 and 24,000 ohms? 		<p>Yes</p> <p>No</p>	<p>GO to NA4 .</p> <p>SERVICE open circuit. REMOVE breakout box. RECONNECT processor. CLEAR Continuous Memory Codes. (Refer to TESTING PROCEDURES/QUICK TEST AND DIAGNOSTIC AIDS/ DETAILED QUICK TEST PROCEDURES/CONTINUOUS MEMORY CODES for procedures). RECONNECT all components. RERUN Quick Test. (Refer to TESTING PROCEDURES/QUICK TEST AND DIAGNOSTIC AIDS/ DETAILED QUICK TEST PROCEDURES /KEY ON ENGINE OFF SELF TEST for test procedures).</p>
NA4	CHECK IDM CIRCUIT CONTINUITY — TFI MODULE TO IGNITION COIL		
<ul style="list-style-type: none"> • Key off. • Processor disconnected. • Measure resistance between Test Pin 5 at the TFI vehicle harness connector and ignition coil harness connector negative terminal. • Is resistance less than 5.0 ohms? 		<p>Yes</p> <p>No</p>	<p>GO to NA5 .</p> <p>SERVICE open circuit. REMOVE breakout box. RECONNECT processor. CLEAR Continuous Memory Codes. (Refer to TESTING PROCEDURES/QUICK TEST AND DIAGNOSTIC AIDS/ DETAILED QUICK TEST PROCEDURES/CONTINUOUS MEMORY CODES for procedures). RECONNECT all components. RERUN Quick Test. (Refer to TESTING PROCEDURES/QUICK TEST AND DIAGNOSTIC AIDS/ DETAILED QUICK TEST PROCEDURES /KEY ON ENGINE OFF SELF TEST for test procedures).</p>

EEC-IV Pinpoint Test

NA5-NA6

*** Updated by TSB #9111B5

TEST STEP		RESULT	ACTION TO TAKE
NA5	CHECK IDM CIRCUIT FOR SHORT TO GROUND	Yes	▶ RECONNECT all components. GO to NA6.
	<ul style="list-style-type: none"> • Key off. • Breakout box installed, processor and TFI module disconnected. • E-core ignition coil disconnected on Non-CCD vehicles. (Refer to Pinpoint Test Schematic). • Measure resistance between Test Pin 4 and Test Pins 40, 46 and 60 at the breakout box. • Is each resistance above 10,000 ohms? 	No	▶ REMOVE breakout box. SERVICE short to ground in IDM circuit. RECONNECT all components. CLEAR Continuous Memory Code. RERUN Quick Test. (Refer to TESTING PROCEDURES/ QUICK TEST AND DIAGNOSTIC AIDS/ DETAILED QUICK TEST PROCEDURES/ CONTINUOUS MEMORY CODES) (Refer to TESTING PROCEDURES/ QUICK TEST AND DIAGNOSTIC AIDS/ DETAILED QUICK TEST PROCEDURES/ KEY ON ENGINE OFF SELF TEST for quick test procedures.)
NA6	CHECK TFI MODULE	No	▶ GO to NA7
	<ul style="list-style-type: none"> • Key off. • Enter Engine Running Continuous Monitor Mode. Refer to TESTING PROCEDURES/QUICK TEST AND DIAGNOSTIC AIDS/DETAILED QUICK TEST PROCEDURES/CONTINUOUS MEMORY CODES for procedures. • Observe VOM or STAR LED for indication of a fault while performing the following: • Lightly tap on TFI ignition module (simulate road shock). • Wiggle TFI module connectors. (7.5L truck, wiggle TFI module and distributor hall connectors.) • Is a fault indicated? 	Yes	▶ DISCONNECT and INSPECT connectors. If connector and terminals are good, REMOVE breakout box, RECONNECT all components and GO to IGNITION SYSTEMS for Ignition Diagnosis.

EEC-IV Pinpoint Test

NA7-NA8

*** Updated by TSB #9111B5

TEST STEP	RESULT	ACTION TO TAKE										
<p>NA7 CHECK EEC-IV HARNESS</p> <ul style="list-style-type: none"> • Still in continuous monitor mode from Step NA6. • While looking for faults listed in the table below, grasp the harness close to the TFI module connector. (For 7.5L Truck, TFI module and distributor hall connectors.) Wiggle, shake or bend a small section of the EEC-IV system harness while working your way to the other ignition system components and to the dash panel. Also wiggle, shake or bend the EEC-IV harness from the dash panel to the processor. Do this test on the circuits listed one at a time if needed to locate a faulty circuit. <table border="1" data-bbox="207 541 724 764"> <thead> <tr> <th>Fault</th> <th>Breakout Box No.</th> </tr> </thead> <tbody> <tr> <td>PIP shorted to ground or open</td> <td>Test Pin 56</td> </tr> <tr> <td>Spout shorted to ground</td> <td>Test Pin 36</td> </tr> <tr> <td>Ign. ground open</td> <td>Test Pin 16</td> </tr> <tr> <td>IDM open or shorted to ground, power</td> <td>Test Pin 4</td> </tr> </tbody> </table> <ul style="list-style-type: none"> • Is a fault indicated? 	Fault	Breakout Box No.	PIP shorted to ground or open	Test Pin 56	Spout shorted to ground	Test Pin 36	Ign. ground open	Test Pin 16	IDM open or shorted to ground, power	Test Pin 4	<p>Yes</p> <p>No</p>	<p>ISOLATE fault and make necessary repairs. REMOVE breakout box. RECONNECT all components. CLEAR Continuous Memory. RERUN Quick Test. (Refer to TESTING PROCEDURES/ QUICK TEST AND DIAGNOSTIC AIDS/ DETAILED QUICK TEST PROCEDURES/ CONTINUOUS MEMORY CODES for code clearing procedures.)</p> <p>(Refer to TESTING PROCEDURES/ QUICK TEST AND DIAGNOSTIC AIDS/ DETAILED QUICK TEST PROCEDURES/ KEY ON ENGINE OFF SELF TEST for quick test procedures.)</p> <p>GO to NA8.</p>
Fault	Breakout Box No.											
PIP shorted to ground or open	Test Pin 56											
Spout shorted to ground	Test Pin 36											
Ign. ground open	Test Pin 16											
IDM open or shorted to ground, power	Test Pin 4											
<p>NA8 CHECK PROCESSOR AND HARNESS CONNECTORS</p> <ul style="list-style-type: none"> • Key off. • Disconnect processor 60 pin connector. Inspect for damaged or pushed out pins, corrosion, loose wires, etc. • Are connectors and terminals OK? 	<p>Yes</p> <p>No</p>	<p>GO to NA9</p> <p>SERVICE as necessary. REMOVE breakout box. RECONNECT all components. CLEAR Continuous Memory Codes. RERUN Quick Test</p> <p>(Refer to TESTING PROCEDURES/ QUICK TEST AND DIAGNOSTIC AIDS/ DETAILED QUICK TEST PROCEDURES/ CONTINUOUS MEMORY CODES for code clearing procedures.)</p> <p>(Refer to TESTING PROCEDURES/ QUICK TEST AND DIAGNOSTIC AIDS/ DETAILED QUICK TEST PROCEDURES/ KEY ON ENGINE OFF SELF TEST for quick test procedures.)</p>										

EEC-IV Pinpoint Test

NA9

*** Updated by TSB #9111B5

TEST STEP		RESULT	ACTION TO TAKE
NA9	CHECK PROCESSOR FOR SHORT TO GROUND	Yes	<p>For Continuous Memory Code 14/211: Unable to duplicate an erratic ignition fault in the EEC-IV system. REMOVE breakout box. RECONNECT all components. For further diagnosis, GO to IGNITION SYSTEMS.</p> <p>For Continuous Memory Code 18/212: REPLACE processor. REMOVE breakout box. RECONNECT all components. Start engine and run for about one minute. RERUN Quick Test. (Refer to TESTING PROCEDURES/QUICK TEST AND DIAGNOSTIC AIDS/ DETAILED QUICK TEST PROCEDURES/KEY ON ENGINE OFF SELF TEST for quick test procedures).</p>
	<ul style="list-style-type: none"> • Key off. • Install breakout box. • Connect processor to breakout box. • Ignition coil and TFI module disconnected. • Measure resistance between Test Pin 4 and Test pin 40, 46 or 60 at breakout box. • Is each resistance greater than 10,000 ohms? 	No	<p>REPLACE processor. REMOVE breakout box. RECONNECT all components. RERUN Quick Test. (Refer to TESTING PROCEDURES/QUICK TEST AND DIAGNOSTIC AIDS/ DETAILED QUICK TEST PROCEDURES/KEY ON ENGINE OFF SELF TEST for quick test procedures).</p>

EEC-IV Pinpoint Test

Note

You should enter this Pinpoint Test only when checking computed timing, or you have been directed here from Quick Test.

Remember

To prevent the replacement of good components, be aware that the following non-EEC areas may be at fault:

- Base Engine
- Distributor
- TFI Module

This Pinpoint Test is intended to diagnose only the following:

- Harness circuit: SPOUT
- Base Timing
- Processor Assembly (-12A650-)

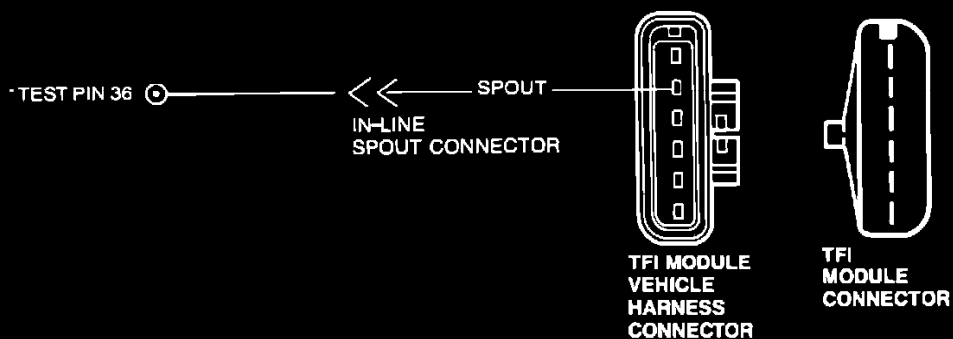
Pinpoint Test Schematic**ALL TFI APPLICATIONS**

*TEST PINS LOCATED ON BREAKOUT BOX.
ALL HARNESS CONNECTORS VIEWED INTO MATING SURFACE.

Test Pin 36	SPOUT
Application	Wire Color
2.9L, 3.0L, F-Series	PK
All Others	Y/LG

EEC-IV Pinpoint Test

TEST STEP		RESULT	ACTION TO TAKE
PA1	ENGINE RUNNING SERVICE CODE 18/213: CHECK COMPUTED SPARK TIMING	Yes	GO to TESTING PROCEDURES/QUICK TEST AND DIAGNOSTIC AIDS/DETAILED QUICK TEST PROCEDURES/VISUAL INSPECTION.
	<p>Engine Running Service Code 18/213 indicates that the SPOUT circuit is open.</p> <p>Possible causes:</p> <ul style="list-style-type: none"> — Open harness. — Processor. — TFI module. <p>NOTE: Self-Test locks the computed timing at base timing plus 20 degrees (± 3 degrees) during code output and for two minutes after the last service code is outputted. Timing check must be made during this time period. See VECI decal for base timing value.</p> <ul style="list-style-type: none"> • Check computed timing. Record value. • Is computed timing equal to base timing plus 20 degrees (± 3 degrees) 	No	GO to PA2 .
PA2	CHECK BASE SPARK TIMING	Yes	RECONNECT SPOUT connector. GO to PA3 .
	<ul style="list-style-type: none"> • Key off. • Locate in-line SPOUT connector and open this connection. • Start engine. • Check base timing. • Is base timing within ± 3 degrees of value on VECI decal? 	No	Adjust base timing if necessary. REFER to IGNITION SYSTEM for engine timing instructions. After timing is reset, RECONNECT in-line SPOUT connector and GO to TESTING PROCEDURES/QUICK TESTS AND DIAGNOSTIC AIDS/COMPUTED TIMING CHECK.

EEC-IV Pinpoint Test

TEST STEP		RESULT	ACTION TO TAKE
PA3	CHECK FOR POWER TO PROCESSOR		
<ul style="list-style-type: none"> • Key off. • Disconnect processor 60 pin connector. Inspect for damaged or pushed out pins, corrosion, loose wires. Service as necessary. • Install breakout box, leave processor disconnected. • Key on, engine off. • Measure voltage between Test Pin 37 and Test Pin 40 at the breakout box. • Measure voltage between Test Pin 57 and Test Pin 60 at the breakout box. • Is each voltage greater than 10.5 volts? 		Yes No	GO to PA4 . GO to PINPOINT TEST B, STEP B1 .
PA4	CHECK SPOUT CIRCUIT CONTINUITY		
<ul style="list-style-type: none"> • Key off. • Breakout box installed, processor disconnected. • Disconnect TFI module. • Measure resistance between Test Pin 36 at the breakout box and SPOUT circuit at the TFI module vehicle harness connector. • Is resistance less than 5 ohms? <div style="text-align: center;"> <p>TFI MODULE VEHICLE HARNESS CONNECTOR</p> <p>TEST PIN 36</p> <p>IN LINE SPOUT CONNECTOR</p> <p>SPOUT</p> </div>		Yes No	GO to PA5 . SERVICE open circuit. REMOVE breakout box. RECONNECT all components. CHECK timing per PA1 .

EEC-IV Pinpoint Test

TEST STEP		RESULT	ACTION TO TAKE
PA5	CHECK SPOUT VOLTAGE AT PROCESSOR		
<ul style="list-style-type: none"> • Key off. • Breakout box installed. • Connect processor to breakout box. • Reconnect TFI module. • Timing switch to "DIST" position on breakout box. • DVOM on 20 volt AC scale. • Start engine. • Measure voltage between Test Pin 36 at the breakout box and battery negative post. • Is AC voltage between 4.0 and 10.0 volts? 		Yes	EEC system OK. REMOVE breakout box. RECONNECT processors. GO to IGNITION SYSTEMS for diagnosis.
		No	REPLACE processor. REMOVE breakout box. RERUN Quick Test. (Refer to TESTING PROCEDURES/QUICK TEST AND DIAGNOSTIC AIDS/DETAILED QUICK TEST PROCEDURES/KEY ON ENGINE OFF SELF TEST for quick test procedures).

EEC-IV Pinpoint Test

Note

You should enter this Pinpoint Test only when you have been directed here from Quick Test.

Remember

This Pinpoint Test is intended to diagnose only the following:

- Processor (12A650)
- EEC Power Relay (12A646)
- Harness Circuits: SIG RTN, STO, STI, VPWR, VREF

Pinpoint Test Schematic

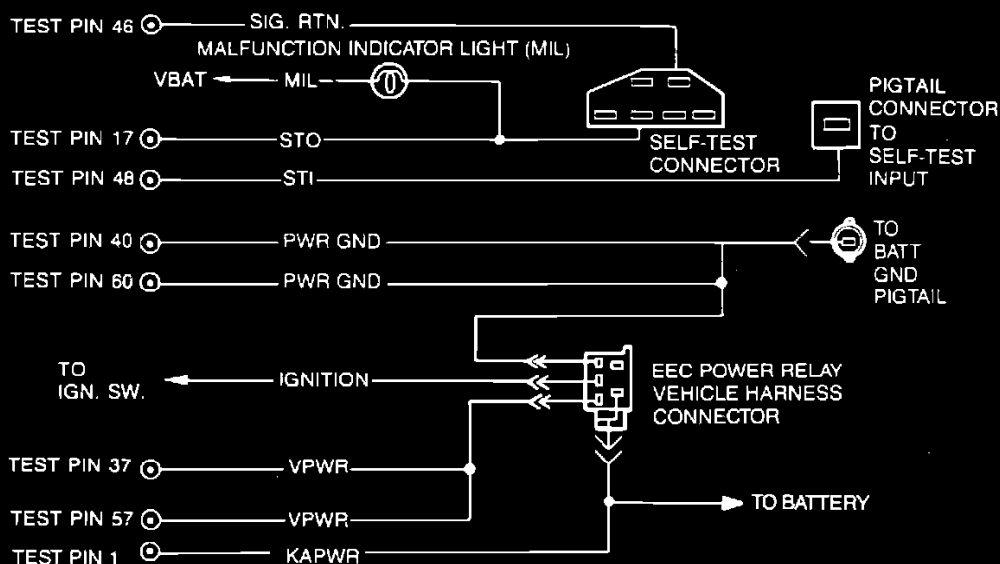

*TEST PINS LOCATED ON BREAKOUT BOX.
ALL HARNESS CONNECTORS VIEWED INTO MATING SURFACE.

EEC-IV Pinpoint Test

Test Pin 17		STO and MIL		Test Pin 48		STI	
Application	Wire Color	Application	Wire Color	Application	Wire Color	Application	Wire Color
2.3L EFI Ranger	PK/LG	4.0L EFI Aerostar	W/R	4.0L EFI Aerostar	W/P	4.0L EFI Aerostar	R
2.9L EFI Ranger		4.9L EFI E-Series		4.9L EFI E-Series			
2.9L MA EFI Ranger		5.0L EFI E-Series		5.0L EFI E-Series			
3.0L EFI Ranger		5.8L EFI E-Series		5.8L EFI E-Series			
4.0L EFI Ranger/Explorer		7.3L E4OD Diesel E-Series		7.3L E4OD Diesel E-Series			
4.9L EFI F-Series/Bronco		7.5L EFI E-Series		7.5L EFI E-Series			
5.0L EFI F-Series/Bronco		All Others		All Others			
5.8L EFI F-Series/Bronco							
5.8L EFI F-Series/Bronco							
7.3L E4OD Diesel F-Series							
7.5L EFI F-Series							
All Others	T/R						

Test Pin 37/57		VPWR	
Application	Wire Color	Application	Wire Color
All	R		

EEC-IV Pinpoint Test

TEST STEP		RESULT	ACTION TO TAKE
QA1	CHECK VREF VOLTAGE AT SELF-TEST CONNECTOR		
<p>NOTE: After market devices such as an alarm system may cause self-test to abort if wiring is connected to certain EEC components. If such a device is installed, disconnect it completely from the EEC system, restore EEC circuits to original, and rerun Quick Test before proceeding with this Pinpoint Test.</p> <ul style="list-style-type: none"> • Key off. • Disconnect processor 60 pin connector. Inspect for damaged or pushed out pins, corrosion, loose wires, etc. Service as necessary. • Install breakout box and connect processor to breakout box. • Key on, engine off. • Measure voltage between Test Pin 26 at the breakout box and SIG RTN circuit in the Self-Test connector. • Is voltage between 4.0 and 6.0 volts? 		<p>Yes</p> <p>No</p>	<p>GO to QA2 .</p> <p>GO to PINPOINT TEST C, STEP C1</p>
QA2	CHECK STI CIRCUIT CONTINUITY		
<ul style="list-style-type: none"> • Breakout box installed. • Disconnect processor. • Measure resistance between STI circuit in the Self-Test single pin pigtail connector and Test Pin 48 at the breakout box. • Is resistance less than 5 ohms? 		<p>Yes</p> <p>No</p>	<p>GO to QA3 .</p> <p>SERVICE open circuit. REMOVE breakout box. RECONNECT processor. RERUN Quick Test.</p> <p>(Refer to TESTING PROCEDURES/QUICK TEST AND DIAGNOSTIC AIDS/DETAILED QUICK TEST PROCEDURES/KEY ON ENGINE OFF SELF TEST for quick test procedures)</p>
QA3	CHECK STO CIRCUIT CONTINUITY		
<ul style="list-style-type: none"> • Key off. • Breakout box installed, processor disconnected. • Measure resistance between STO circuit in the Self-Test connector and Test Pin 17 at the breakout box. • Is resistance less than 5 ohms? 		<p>Yes</p> <p>No</p>	<p>GO to QA4 .</p> <p>SERVICE open circuit. REMOVE breakout box. RECONNECT processor. RERUN Quick Test.</p> <p>(Refer to TESTING PROCEDURES/QUICK TEST AND DIAGNOSTIC AIDS/DETAILED QUICK TEST PROCEDURES/KEY ON ENGINE OFF SELF TEST for quick test procedures)</p>

EEC-IV Pinpoint Test

TEST STEP		RESULT	ACTION TO TAKE
QA4	CHECK HEGO SIGNAL FOR SHORT TO POWER		
	<ul style="list-style-type: none"> Breakout box installed, processor disconnected. Key on, engine off. Measure voltage between HEGO SIGNAL Test Pin 29 or 44 (refer to Pinpoint Test H schematic) and Test Pin 40 or 60 at the breakout box Is voltage greater than 2.0 volts? 	<p>Yes</p> <p>No</p>	<p>GO to QA5 .</p> <p>GO to QA6 .</p>
QA5	ISOLATE SHORT TO HARNESS OR HEGO SENSOR		
	<ul style="list-style-type: none"> Breakout box installed, processor disconnected. Disconnect HEGO (Bank #1) sensor vehicle harness connector. Key on, engine off. Measure voltage between HEGO SIGNAL Test Pin 29 or 44 (refer to schematic below) and Test Pin 40 or 60 at the breakout box Is voltage greater than 2.0 volts? 	<p>Yes</p> <p>No</p>	<p>SERVICE HEGO SIGNAL circuit for shorts to power. REMOVE breakout box. RECONNECT all components. RERUN Quick Test. (Refer to TESTING PROCEDURES/QUICK TEST AND DIAGNOSTIC AIDS/DETAILED QUICK TEST PROCEDURES/KEY ON ENGINE OFF SELF TEST for quick test procedures).</p> <p>REPLACE HEGO (Bank #1) sensor. REMOVE breakout box. RECONNECT all components. RERUN Quick Test. (Refer to TESTING PROCEDURES/QUICK TEST AND DIAGNOSTIC AIDS/DETAILED QUICK TEST PROCEDURES/KEY ON ENGINE OFF SELF TEST for quick test procedures).</p>
QA6	CHECK STO CIRCUIT FOR SHORT TO GROUND		
	<ul style="list-style-type: none"> Key off. Breakout box installed, processor disconnected. Disconnect MIL bulb (unless equipped with message center). Measure resistance between STO circuit in the Self-Test connector and engine block ground. Is resistance less than 10,000 ohms? 	<p>Yes</p> <p>No</p>	<p>SERVICE STO or MIL circuit for short to ground. REMOVE breakout box. RECONNECT processor. RERUN Quick Test. (Refer to TESTING PROCEDURES/QUICK TEST AND DIAGNOSTIC AIDS/DETAILED QUICK TEST PROCEDURES/KEY ON ENGINE OFF SELF TEST for quick test procedures).</p> <p>RECONNECT MIL bulb if applicable. GO to QA7 .</p>

EEC-IV Pinpoint Test

TEST STEP		RESULT	ACTION TO TAKE
QA7	CHECK IF POWER RELAY IS ALWAYS ON		
<ul style="list-style-type: none"> • Key off. • Breakout box installed, processor disconnected. • Connect DVOM to Test Pin 37 or 57 and to Test Pin 40 or 60 at the breakout box. • DVOM on 20 volt scale. • Turn key on and then off. Wait 10 seconds. • Does voltage change from greater than 10.5 volts to less than 1.0 volt? 		Yes	<p>▶ RECONNECT processor. GO to QA9 .</p>
		No	<p>▶ GO to QA8 .</p>
QA8	CHECK VPWR CIRCUIT FOR SHORT TO POWER		
<ul style="list-style-type: none"> • Key off. • Breakout box installed, processor disconnected. • Disconnect EEC Power Relay or Integrated Relay Control Module. • Measure voltage between Test Pin 37 or 57 and Test Pin 40 or 60 at the breakout box. • Is voltage greater than 1.0 volts? 		Yes	<p>▶ SERVICE VPWR circuit short to power. REMOVE breakout box. RECONNECT all components. RERUN Quick Test.</p> <p>(Refer to TESTING PROCEDURES/QUICK TEST AND DIAGNOSTIC AIDS/DETAILED QUICK TEST PROCEDURES/KEY ON ENGINE OFF SELF TEST for quick test procedures).</p>
		No	<p>▶ REPLACE EEC Power Relay or Integrated Relay Controller. REMOVE breakout box. RECONNECT processor. RERUN Quick Test.</p> <p>(Refer to TESTING PROCEDURES/QUICK TEST AND DIAGNOSTIC AIDS/DETAILED QUICK TEST PROCEDURES/KEY ON ENGINE OFF SELF TEST for quick test procedures).</p>
QA9	CHECK MIL FUNCTION		
<ul style="list-style-type: none"> • Are any of these conditions present? • Malfunction indicator light (MIL): <ul style="list-style-type: none"> — Always ON — Always OFF — Functioning normally 			<p>▶ REMOVE breakout box. RECONNECT processor. GO to ML1 .</p> <p>▶ REMOVE breakout box. RECONNECT processor. GO to ML4 .</p> <p>▶ REPLACE the processor. RERUN Quick Test.</p> <p>(Refer to TESTING PROCEDURES/QUICK TEST AND DIAGNOSTIC AIDS/DETAILED QUICK TEST PROCEDURES/KEY ON ENGINE OFF SELF TEST for quick test procedures).</p>

EEC-IV Pinpoint Test

Note

You should enter this Pinpoint Test only when you have been directed here from Quick Test.

Remember

This Pinpoint Test is intended to diagnose only the following:

- Processor (12A650)
- Harness circuit: KAPWR

Pinpoint Test Schematic

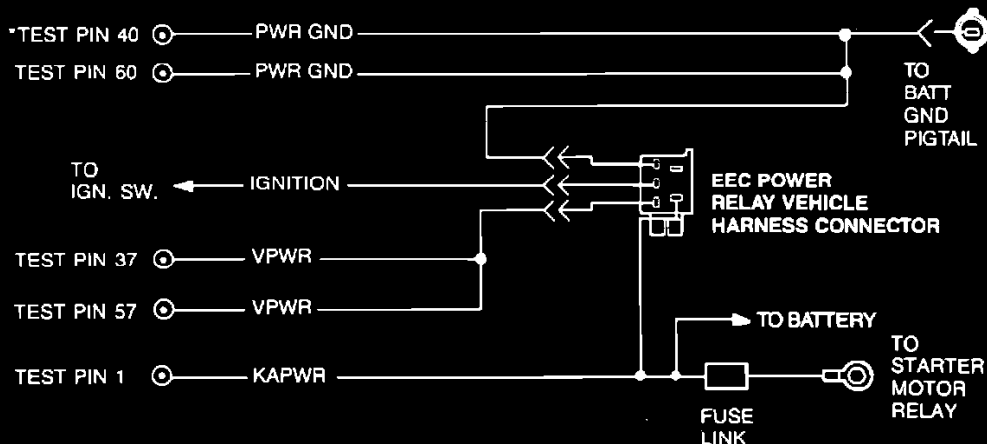

*TEST PINS LOCATED ON BREAKOUT BOX.
ALL HARNESS CONNECTORS VIEWED INTO MATING SURFACE.

EEC-IV Pinpoint Test

Test Pin 1	KAPWR
Application	Wire Color
5.0L EFI E-Series	BK/O
4.9L EFI E-Series	
5.8L EFI E-Series	
7.3L E4OD Diesel E-Series	
7.5L EFI E-Series	
All Others	Y

EEC-IV Pinpoint Test

TEST STEP		RESULT	ACTION TO TAKE
QB1	CONDITIONS FOR CONTINUOUS CODE 15/512		
<p>Continuous Service code 15/512 indicates that the processor has experienced a power interrupt in its keep alive Memory (KAM) circuit.</p> <p>NOTE: If power is interrupted to the processor, for example when installing a breakout box, a Code 15/512 may be present. Rerun Self-Test to ensure correct diagnosis.</p> <p>(Refer to TESTING PROCEDURES/QUICK TEST AND DIAGNOSTIC AIDS/DETAILED QUICK TEST PROCEDURES/KEY ON ENGINE OFF SELF TEST for test procedures).</p> <ul style="list-style-type: none"> • Clear Continuous Memory Codes. (Refer to TESTING PROCEDURES/QUICK TEST AND DIAGNOSTIC AIDS/DETAILED QUICK TEST PROCEDURES/CONTINUOUS MEMORY CODES for procedures). • Wait 5 minutes to allow the code to reset. • Rerun Key On Engine Off Self-Test. • Is Code 15 or 512 present on retest? 		<p>Yes</p> <p>No</p>	<p>GO to QB2 .</p> <p>SERVICE other codes as necessary. If none, testing complete.</p>
QB2	INSPECT ENGINE COMPARTMENT WIRING FOR PROPER ROUTING		
<ul style="list-style-type: none"> • Inspect EEC wiring for closeness to ignition components or wires (High Electrical Energy Sources). If EEC wiring is close, reroute as necessary. • Clear Continuous Memory Codes (Refer to TESTING PROCEDURES /QUICK TEST AND DIAGNOSTIC AIDS/DETAILED QUICK TEST PROCEDURES/CONTINUOUS MEMORY CODES for procedures.) • Wait 5 minutes to allow the code to reset. • Rerun Key On Engine Off Self-Test. <p>(Refer to TESTING PROCEDURES/QUICK TEST AND DIAGNOSTIC AIDS/DETAILED QUICK TEST PROCEDURES/KEY ON ENGINE OFF SELF TEST for test procedures.)</p> <ul style="list-style-type: none"> • Is Code 15 or 512 still present in Continuous Memory? 		<p>Yes</p> <p>No</p>	<p>GO to QB3 .</p> <p>SERVICE other codes as necessary. If none, testing complete.</p>

EEC-IV Pinpoint Test

TEST STEP		RESULT	ACTION TO TAKE
QB3	SERVICE CODE 15/511 CHECK KAPWR CIRCUIT VOLTAGE	Yes	SERVICE open circuit. REMOVE breakout box. RECONNECT processor. RERUN Quick Test. (Refer to TESTING PROCEDURES/QUICK TEST AND DIAGNOSTIC AIDS/DETAILED QUICK TEST PROCEDURES/KEY ON ENGINE OFF SELF TEST for test procedures).
<ul style="list-style-type: none"> • Service code 15/511 indicates that the processor memory (ROM) failed during Key On Engine Off Self-Test. • Key off. • Disconnect processor 60 pin connector. Inspect for damaged or pushed out pins, corrosion, loose wires, etc. Service as necessary. • Install breakout box, leave processor disconnected. • Measure voltage between Test Pin 1 and Test Pin 40 or 60 at the breakout box. • While observing DVOM, grasp the EEC-IV harness and wiggle, shake or bend a small section while working your way from the processor to the dash panel. • Does DVOM indicate less than 10.5 volts? 		No	REPLACE processor. REMOVE breakout box. RERUN Quick Test. (Refer to TESTING PROCEDURES/QUICK TEST AND DIAGNOSTIC AIDS/DETAILED QUICK TEST PROCEDURES/KEY ON ENGINE OFF SELF TEST for test procedures).

EEC-IV Pinpoint Test

Note

You should enter this Pinpoint Test only when you have been directed here from other Pinpoint Tests.

Remember

This Pinpoint Test is intended to diagnose only the following:

- Test Conditions
- Throttle Plate Linkage

EEC-IV Pinpoint Test

TEST STEP		RESULT	ACTION TO TAKE
QC1	CHECK FOR CODES 23, 53, 63, 121, 122 or 123		
<p>NOTE: If vehicle is equipped with speed control, the speed control servo must be electrically disconnected. This prevents the speed control system from affecting the throttle plate movement during Output State Check. Rerun Quick Test or Output State Check.</p> <p>(Refer to TESTING PROCEDURES/QUICK TEST AND DIAGNOSTIC AIDS/DETAILED QUICK TEST PROCEDURES /KEY ON ENGINE OFF SELF TEST for quick test procedures) (Refer to TESTING PROCEDURES/QUICK TEST AND DIAGNOSTIC AIDS/OUTPUT STATE CHECKS for output state check procedures)</p> <ul style="list-style-type: none"> • Key off. • Perform Key On Engine Off Self-Test. (Refer to TESTING PROCEDURES/QUICK TEST AND DIAGNOSTIC AIDS/DETAILED QUICK TEST PROCEDURES /KEY ON ENGINE OFF SELF TEST for quick test procedures) • Are any of these codes 23, 53, 63, 121, 122 or 123 present? 		<p>Yes</p> <p>Code 11 or 111</p> <p>No Codes</p>	<p>GO to TESTING PROCEDURES /QUICK TEST AND DIAGNOSTIC AIDS/QUICK TEST CODES AND DEFINITIONS and service appropriate code as instructed.</p> <p>GO to QC2 .</p> <p>GO to PINPOINT TEST QA, STEP QA1.</p>
QC2	CHECK THROTTLE LINKAGE		
<ul style="list-style-type: none"> • Check throttle and throttle linkages for sticking and binding. • Is throttle OK? 		<p>Yes</p> <p>No</p>	<p>REPLACE TP sensor. RERUN Quick Test. (Refer to TESTING PROCEDURES/QUICK TEST AND DIAGNOSTIC AIDS/DETAILED QUICK TEST PROCEDURES/KEY ON ENGINE OFF SELF TEST for quick test procedures).</p> <p>SERVICE as necessary. RERUN Quick Test. (Refer to TESTING PROCEDURES/QUICK TEST AND DIAGNOSTIC AIDS/DETAILED QUICK TEST PROCEDURES/KEY ON ENGINE OFF SELF TEST for quick test procedures).</p>

EEC-IV Pinpoint Test

Note

You should enter this Pinpoint Test only when you have been directed here from Quick Test Pinpoint Test A or AA.

Remember

To prevent the replacement of good components, be aware that the following Non-EEC areas may be at fault:

- Poor power/ground connections
- Ignition system distributor cap, rotor, wires, coil, plugs
- Base engine valves, cam timing, compression, etc.

This Pinpoint Test is intended only as a Quick Check for the basic functioning of the following:

- ISC Bypass Air System
- MAP System
- EGR System
- MAF System

EEC-IV Pinpoint Test

TEST STEP		RESULT	ACTION TO TAKE
S1	ISC-BPA CHECK		
	<ul style="list-style-type: none"> • Attempt to start engine at part throttle. • Will engine run smooth at part throttle? 	Yes ▶ No ▶	GO to PINPOINT TEST KE, STEP KE4 GO to S3 .
S2	CHECK FOR RPM DROP		
	<ul style="list-style-type: none"> • Key off. • Connect engine tachometer. • Start engine. • Disconnect ISC solenoid. • Does rpm drop or stall? 	Yes ▶ No ▶	RECONNECT ISC solenoid. GO to S3 . GO to PINPOINT TEST KE, STEP KE4
S3	POWER TO MAP/BP SENSOR TEST		
	<p>NOTE: If the vehicle being checked is not equipped with MAP/BP system hardware go directly to S8 . Green light on tester indicates VREF is OK. Red Light (or no light) indicates VREF is either too low or too high.</p> <ul style="list-style-type: none"> • Key off. • Disconnect the MAP/BP sensor from the vehicle harness. • Connect the MAP/BP tester between the vehicle harness and the MAP/BP sensor, (refer to schematic below). • Insert MAP/BP tester banana plugs into DVOM. • Key on, engine off. • Is green light on? 	Yes ▶ No ▶	GO to S4 . SERVICE open VREF circuit. REMOVE MAP/BP tester. RECONNECT MAP/BP. RE-EVALUATE symptom.

EEC-IV Pinpoint Test

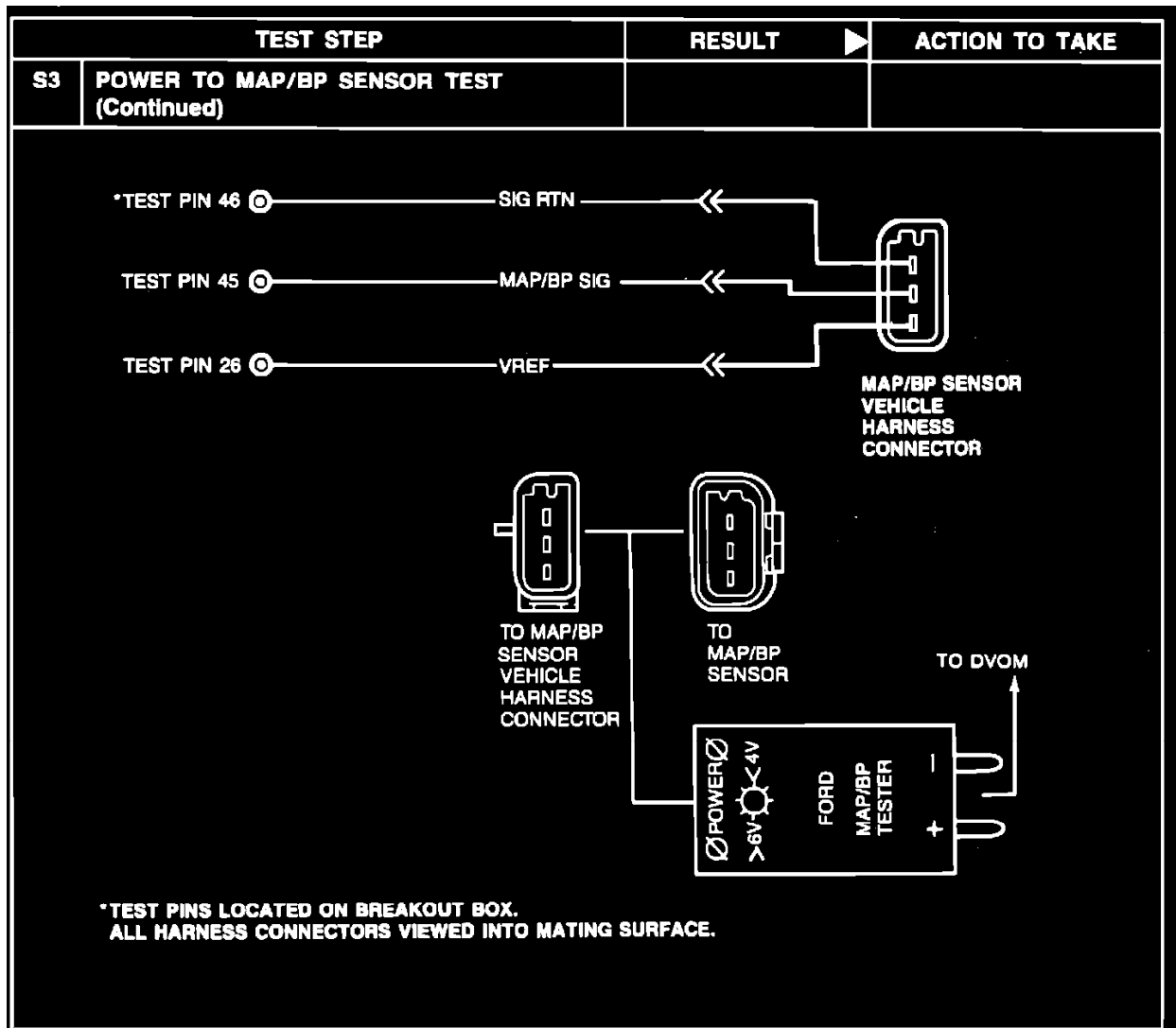

EEC-IV Pinpoint Test

TEST STEP		RESULT	ACTION TO TAKE																		
S4	MAP/BP TESTER OUTPUT READING																				
<p>NOTE: Measure several known good MAP/BP sensors on available vehicles. The measured voltage will be typical for your location on the day of testing.</p> <ul style="list-style-type: none"> MAP/BP Tester and DVOM connected. Key on. <table border="1"> <thead> <tr> <th><u>Approximate Altitude (Ft.)</u></th> <th><u>Voltage Output (+/- .04 Volts)</u></th> </tr> </thead> <tbody> <tr><td>0</td><td>1.59</td></tr> <tr><td>1000</td><td>1.56</td></tr> <tr><td>2000</td><td>1.53</td></tr> <tr><td>3000</td><td>1.50</td></tr> <tr><td>4000</td><td>1.47</td></tr> <tr><td>5000</td><td>1.44</td></tr> <tr><td>6000</td><td>1.41</td></tr> <tr><td>7000</td><td>1.39</td></tr> </tbody> </table> <ul style="list-style-type: none"> Is voltage in range for your altitude? 		<u>Approximate Altitude (Ft.)</u>	<u>Voltage Output (+/- .04 Volts)</u>	0	1.59	1000	1.56	2000	1.53	3000	1.50	4000	1.47	5000	1.44	6000	1.41	7000	1.39	<p>Yes</p> <p>No (Sensor output is out-of-range)</p>	<p>▶ For vehicles with Mass Air Flow sensors: GO to S8 .</p> <p>▶ For all others: GO to S5 .</p> <p>▶ REPLACE MAP/BP sensor.</p>
<u>Approximate Altitude (Ft.)</u>	<u>Voltage Output (+/- .04 Volts)</u>																				
0	1.59																				
1000	1.56																				
2000	1.53																				
3000	1.50																				
4000	1.47																				
5000	1.44																				
6000	1.41																				
7000	1.39																				
S5	CHECK VACUUM LINES																				
<ul style="list-style-type: none"> Check vacuum lines for proper routing. Refer to VECI decal. Check MAP sensor vacuum line for holes, disconnections, kinks or blockage. Are vacuum lines OK? 		<p>Yes</p> <p>No</p>	<p>▶ GO to S6 .</p> <p>▶ SERVICE vacuum lines as necessary. RERUN Quick Test. (Refer to TESTING PROCEDURES/QUICK TEST AND DIAGNOSTIC AIDS/DETAILED QUICK TEST PROCEDURES/KEY ON ENGINE OFF SELF TEST for quick test procedures)</p>																		
S6	CHECK MAP SENSOR																				
<ul style="list-style-type: none"> Key off. Disconnect MAP vacuum hose from manifold tee. Install vacuum pump to MAP vacuum hose. Apply 18 in-Hg vacuum to MAP sensor. Does MAP sensor and vacuum hose hold vacuum? 		<p>Yes</p> <p>No</p>	<p>▶ RELEASE vacuum. REMOVE vacuum pump. GO to S7 .</p> <p>▶ REPLACE MAP sensor. RECONNECT vacuum line to MAP sensor. RERUN Quick Test. (Refer to TESTING PROCEDURES/QUICK TEST AND DIAGNOSTIC AIDS/DETAILED QUICK TEST PROCEDURES/KEY ON ENGINE OFF SELF TEST for quick test procedures).</p>																		

EEC-IV Pinpoint Test

TEST STEP		RESULT	ACTION TO TAKE
S7	CHECK VACUUM MANIFOLD SOURCE		
<ul style="list-style-type: none"> • Key off. • MAP vacuum hose from manifold vacuum tee disconnected. • Install vacuum gauge to manifold vacuum tee. • Start/crank engine. • Is manifold vacuum present at the vacuum tee? 		<p>Yes ▶</p> <p>No ▶</p>	<p>REMOVE vacuum gauge. RECONNECT vacuum line to MAP sensor and manifold vacuum tee. GO to S8 .</p> <p>REMOVE obstruction in manifold vacuum tee or REPLACE damaged manifold vacuum tee. RERUN Quick Test. (Refer to TESTING PROCEDURES/QUICK TEST AND DIAGNOSTIC AIDS/DETAILED QUICK TEST PROCEDURES/KEY ON ENGINE OFF SELF TEST for quick test procedures).</p>
S8	CHECK EGR VACUUM		
<p>NOTE: If the vehicle being checked is not equipped with EGR system hardware, go directly to PINPOINT TEST H, STEP H2. The next two test steps will attempt to determine if the EGR system is the cause of the current symptom and/or NO START.</p> <ul style="list-style-type: none"> • Disconnect vacuum line at EGR valve, and plug the vacuum line. • Start engine. <p>For Drive Symptom:</p> <p>— Was drive symptom eliminated?</p> <p>For No Start:</p> <p>— Does engine start?</p>		<p>Yes ▶</p> <p>No ▶</p>	<p>For vehicles with EVP sensors: GO to PINPOINT TEST DN, STEP DN42</p> <p>For all others: GO to PINPOINT TEST DL, STEP DL21</p> <p>GO to S9 .</p>
S9	CHECK EGR VALVE		
<ul style="list-style-type: none"> • Inspect EGR valve to ensure proper seating. • Is EGR valve fully seated (closed)? 		<p>Yes ▶</p> <p>No ▶</p>	<p>GO to PINPOINT TEST H, STEP H2</p> <p>GO to EMISSION CONTROLS for EGR valve diagnosis.</p>

EEC-IV Pinpoint Test

Note

You should enter this Pinpoint Test only when you have been directed here from Quick Test.

Remember

This Pinpoint Test is intended to diagnose only the following:

- Clutch engage/interlock switch (11A152)
- Neutral drive/gear switch (7A247)
- Processor (12A650)
- Harness circuits: CES, CIS, NDS, NGS, and SIG RTN

EEC-IV Pinpoint Test

Test Pin 30		NDS	
Application		Wire Color	
2.3L Truck 2.9L Truck		W/BK	
4.9L E-Series 5.0L E-Series 5.8L E-Series 7.3L E-Series Diesel		W/R	
2.3L 2.9L 3.0L 4.0L 4.9L F-Series 5.0L F-Series 5.8L F-Series 7.3L F-Series Diesel 7.5L F-Series		LB/Y	
Test Pin 46		SIG RTN	
Application		Wire Color	
All		GY/R	

EEC-IV Pinpoint Test

TEST STEP		RESULT	ACTION TO TAKE
TA1	CODE 67/522, 525, 527, 528 or 634 SYSTEM IDENTIFICATION		
<p>A Code 67/522, 525, 527, 528 or 634 resulted from the voltage being high at either:</p> <ul style="list-style-type: none"> — Pin 10 = A/C input — Pin 30 = Neutral drive <p>while cranking the engine or during KOEO test.</p> <p>Possible causes are:</p> <ul style="list-style-type: none"> — A/C circuit shorted to power — Clutch engage/interlock circuits open — Neutral drive/gear switch open — Faulty processor — Starter relay disconnected during Self-Test. <p>For Manual Transmissions: 5.0L, 5.8L, 7.5L 3.0L SHO and 4.9L</p> <p>For E40D Transmissions: 4.9L, 5.0L, 5.8L, 7.5L, 7.3L Diesel</p> <p>For all other engines:</p>			
		→	GO to POINT TEST KM, STEP KM40
		→	GO to TA7 .
		→	GO to POINT TEST KM, STEP KM40
		→	GO to TA8 .

EEC-IV Pinpoint Test

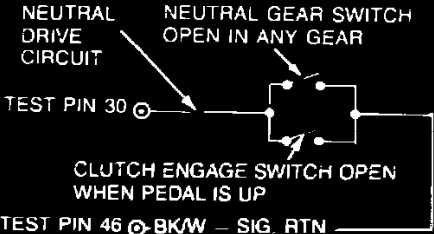
TEST STEP	RESULT	ACTION TO TAKE
<p>TA2 CHECK NEUTRAL GEAR/CLUTCH INPUT</p> <ul style="list-style-type: none"> • Key off. • Verify A/C is off, if so equipped. • Disconnect processor 60 pin connector. Inspect for damaged or pushed out pins, corrosion, loose wires, etc. Service as necessary. • Install breakout box, leave processor disconnected. • Measure resistance between Test Pin 30 and Test Pin 46. <ol style="list-style-type: none"> 1. With transmission in NEUTRAL and the clutch pedal up. 2. With transmission in GEAR and the clutch pedal down. <ul style="list-style-type: none"> • Is each resistance less than 5 ohms?  <p>NEUTRAL DRIVE CIRCUIT</p> <p>NEUTRAL GEAR SWITCH OPEN IN ANY GEAR</p> <p>TEST PIN 30</p> <p>CLUTCH ENGAGE SWITCH OPEN WHEN PEDAL IS UP</p> <p>TEST PIN 46 BK/W - SIG. RTN</p>	<p>Yes</p> <p>No</p>	<p>GO to TA3 .</p> <p>GO to TA5 .</p>
<p>TA3 CHECK NEUTRAL GEAR/CLUTCH INPUT INTEGRITY</p> <ul style="list-style-type: none"> • Key off. • Breakout box installed, processor disconnected. • Processor disconnected. • Measure resistance between Test Pin 30 and Test Pin 46 at the breakout box with transmission in any gear and the clutch pedal up. • Is resistance less than 5 ohms? 	<p>Yes</p> <p>No</p>	<p>For vehicles with A/C: GO to PINPOINT TEST KM, STEP KM40.</p> <p>All others: REPLACE processor. REMOVE breakout box. RERUN Quick Test. (Refer to TESTING PROCEDURES/QUICK TEST AND DIAGNOSTIC AIDS/DETAILED QUICK TEST PROCEDURES/KEY ON ENGINE OFF SELF TEST for quick test procedures).</p> <p>GO to TA4 .</p>

EEC-IV Pinpoint Test

TEST STEP		RESULT	ACTION TO TAKE
TA4	CHECK FOR SHORT TO GROUND	Yes	For vehicles with A/C: GO to PINPOINT TEST KM, STEP KM40 All others: REPLACE processor. REMOVE breakout box. RERUN Quick Test. (Refer to TESTING PROCEDURES/ QUICK TEST AND DIAGNOSTIC AIDS/ DETAILED QUICK TEST PROCEDURES/ KEY ON ENGINE OFF SELF TEST for quick test procedures.)
	<ul style="list-style-type: none"> • Key off. • Breakout box installed, processor disconnected. • Disconnect Clutch Engage Switch. • Measure resistance between Test Pin 30 and Test Pin 46 at the breakout box. • Is resistance greater than 10,000 ohms? 	No	SERVICE short circuit. REMOVE breakout box. RECONNECT processor. RERUN Quick Test. (Refer to TESTING PROCEDURES/ QUICK TEST AND DIAGNOSTIC AIDS/ DETAILED QUICK TEST PROCEDURES/ KEY ON ENGINE OFF SELF TEST for quick test procedures.)
TA5	CHECK NEUTRAL GEAR/CLUTCH ENGAGE SWITCH	Yes	GO to TA6 .
	<ul style="list-style-type: none"> • Key off. • Breakout box installed, processor disconnected • Locate Neutral Gear Switch (on transmission) and Clutch Engage Switch (at clutch pedal linkage). • Disconnect vehicle harness at both switches and inspect connectors for pushed back pins. • Measure resistance across the Neutral Gear switch terminals with transmission in neutral and across the Clutch switch terminals with the clutch pedal down. • Is each resistance less than 5 ohms? 	No	REPLACE open switch(es). REMOVE breakout box. RECONNECT all components. RERUN Quick Test. (Refer to TESTING PROCEDURES/ QUICK TEST AND DIAGNOSTIC AIDS/ DETAILED QUICK TEST PROCEDURES/ KEY ON ENGINE OFF SELF TEST for quick test procedures.)
TA6	CHECK NEUTRAL GEAR/CLUTCH HARNESS	Yes	For vehicles with A/C: GO to PINPOINT TEST KM, STEP KM40 For all others: REPLACE processor.
	<ul style="list-style-type: none"> • Key off. • DVOM on 200 ohm scale. • Breakout box installed, processor disconnected. • Vehicle harness disconnected at the Neutral Gear switch and Clutch switch. • Measure resistance between Test Pin 30 and the Neutral Gear Switch harness connector and between Test Pin 30 and the Clutch Engage Switch harness connector. • Measure resistance between Test Pin 46 and the Neutral Gear Switch harness connector and between Test Pin 46 and the Clutch Engage Switch harness connector. • Is each resistance less than 5 ohms? 	No	SERVICE open circuit. REMOVE breakout box. RECONNECT all components. RERUN Quick Test. (Refer to TESTING PROCEDURES/ QUICK TEST AND DIAGNOSTIC AIDS/ DETAILED QUICK TEST PROCEDURES/ KEY ON ENGINE OFF SELF TEST for quick test procedures.)

EEC-IV Pinpoint Test

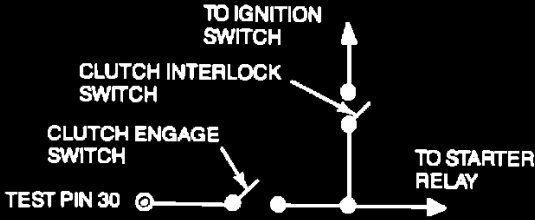
TEST STEP		RESULT	ACTION TO TAKE
TA7	CHECK CLUTCH ENGAGE SWITCH		
<p>NOTE: For 4.9L engines, the clutch pedal must be down during KOEO test; if not, a Code 67/528 will result.</p> <ul style="list-style-type: none"> • Key off. • Disconnect processor 60 pin connector. Inspect for damaged or pushed out pins, corrosion, loose wires, etc. Service as necessary. • Install breakout box, leave processor disconnected. • Clutch pedal down. • Measure resistance between Test Pin 30 and Test Pin 40. • Is each resistance less than 5 ohms?  <p>The diagram shows a series circuit starting from Test Pin 30 (indicated by a ground symbol). The circuit passes through the Clutch Engage Switch, then the Clutch Interlock Switch, and finally the Ignition Switch. From the Ignition Switch, the circuit branches: one path goes up to the Ignition Switch, and another path goes right to the Starter Relay. The Clutch Engage Switch is connected to the Clutch Interlock Switch, which is connected to the Ignition Switch.</p>		<p>Yes</p> <p>▶ For vehicles with A/C: GO to PINPOINT TEST KM, STEP KM40</p> <p>For all others: REPLACE processor.</p> <p>No</p> <p>▶ SERVICE open circuit. REMOVE breakout box. RECONNECT all components.</p>	

EEC-IV Pinpoint Test

TEST STEP		RESULT	ACTION TO TAKE
TA8	CHECK NEUTRAL DRIVE INPUT		
<ul style="list-style-type: none"> • Key off. • Verify heater control is in OFF position, if so equipped. • Verify transmission is in NEUTRAL or PARK. • Disconnect processor 60 pin connector. Inspect for damaged or pushed out pins, corrosion, loose wires, etc. Service as necessary. • Install breakout box, leave processor connected. • Key on, engine off. • Measure voltage between Test Pin 30 at the breakout box and chassis ground. • Is voltage less than 1.0 volt? <div style="text-align: center;"> <p>TO IGNITION SWITCH</p> <p>TEST PIN 30</p> <p>TO STARTER RELAY</p> <p>NEUTRAL DRIVE CIRCUIT</p> <p>CLOSED IN PARK AND NEUTRAL</p> </div>		<p>Yes</p> <p>No</p>	<p>For vehicles with A/C: GO to PINPOINT TEST KM, STEP KM40</p> <p>For all others: REPLACE processor.</p> <p>Go to TA9 .</p>
TA9	CHECK NEUTRAL DRIVE SWITCH		
<ul style="list-style-type: none"> • Key off. • Breakout box installed, processor disconnected. • Locate the Neutral Drive Switch. • Disconnect vehicle harness from the Neutral Drive Switch and measure resistance across the switch. • Is resistance less than 5 ohms? 		<p>Yes</p> <p>No</p>	<p>SERVICE open in vehicle harness Neutral Drive circuit. REMOVE breakout box. RECONNECT all components. RERUN Quick Test. (Refer to TESTING PROCEDURES/ QUICK TEST AND DIAGNOSTIC AIDS/ DETAILED QUICK TEST PROCEDURES/ KEY ON ENGINE OFF SELF TEST for quick test procedures.)</p> <p>REPLACE Neutral Drive Switch. REMOVE breakout box. RECONNECT all components. RERUN Quick Test. (Refer to TESTING PROCEDURES/ QUICK TEST AND DIAGNOSTIC AIDS/ DETAILED QUICK TEST PROCEDURES/ KEY ON ENGINE OFF SELF TEST for quick test procedures.)</p>

EEC-IV Pinpoint Test

TEST STEP	RESULT	ACTION TO TAKE
<p>TA10 CHECK NEUTRAL DRIVE INPUT</p> <ul style="list-style-type: none"> • Key off. • Verify transmission is in PARK or NEUTRAL. • Disconnect processor 60 pin connector. Inspect for damaged or pushed out pins, corrosion, loose wires, etc. Service as necessary. • Install breakout box and connect processor to breakout box. • Disconnect 16 pin connector from the 4EAT module. • Key on, engine off. • Measure voltage between Test Pin 30 at the breakout box and chassis ground. • Is voltage less than 1.0 volt?  <pre> TEST PIN 30 ○ — BR/Y — NDS —> TO 4EAT MODULE </pre>	<p>Yes</p> <p>No</p>	<p>REPLACE processor. REMOVE breakout box. RECONNECT all components. RERUN Quick Test. (Refer to TESTING PROCEDURES/QUICK TEST AND DIAGNOSTIC AIDS/DETAILED QUICK TEST PROCEDURES/KEY ON ENGINE OFF SELF TEST for quick test procedures).</p> <p>Key off. GO to TA11 .</p>

EEC-IV Pinpoint Test

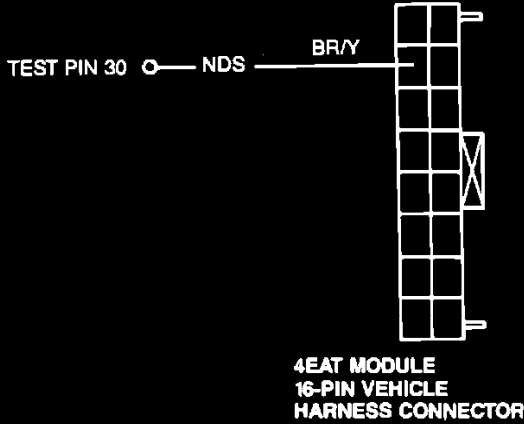
TEST STEP		RESULT	ACTION TO TAKE
TA11	CHECK NDS CIRCUIT CONTINUITY BETWEEN PROCESSOR AND 4EAT MODULE	Yes	▶ GO to TRANSMISSIONS, CLUTCHES, DIFFERENTIAL AXLES, AND DRIVE SHAFTS for 4EAT system diagnosis. REMOVE breakout box and RECONNECT all components when testing is complete.
<ul style="list-style-type: none"> • Key off. • 4EAT module 16 pin connector disconnected. • Breakout box installed. • Disconnect processor. • Measure resistance between Test Pin 30 at the breakout box and the NDS pin at the 4EAT module vehicle harness connector. • Is resistance less than 5.0 ohms?  <p style="text-align: center;">4EAT MODULE 16-PIN VEHICLE HARNESS CONNECTOR</p>		No	▶ SERVICE open circuit. REMOVE breakout box. RECONNECT all components. RERUN Quick Test. (Refer to TESTING PROCEDURES/QUICK TEST AND DIAGNOSTIC AIDS/DETAILED QUICK TEST PROCEDURES/KEY ON ENGINE OFF SELF TEST for quick test procedures)
TA12	CHECK NDS CIRCUIT FOR SHORT TO GROUND OR CLOSED NEUTRAL DRIVE SWITCH	Yes	▶ GO to TESTING PROCEDURES/DIAGNOSTIC ROUTINES for other possible causes, HIGH IDLE (ENGINE DIESELS)
<ul style="list-style-type: none"> • Key off. • Disconnect processor 60 pin connector. Inspect for damaged or pushed out pins, corrosion, loose wires, etc. Service as necessary. • Install breakout box, leave processor disconnect. • Place transmission in DRIVE. • DVOM on 200,000 ohm scale. • Measure resistance between Test Pin 30 and Test Pin 40/60 at the breakout box. • Is resistance greater than 10,000 ohms? 		No	▶ SERVICE short circuit or closed Neutral Drive Switch. REMOVE breakout box. RECONNECT processor. RE-EVALUATE symptom.

EEC-IV Pinpoint Test

Note

You should enter this Pinpoint Test only when you have been directed here from Quick Test.

Remember

This Pinpoint Test is not intended to diagnose components interior to the transmission. To prevent the replacement of good components, be aware that the following non-EEC areas may be at fault:

- Engine
 - Performance, Vacuum, Cooling, Brakes.
- Electrical
 - Alternator, Battery integrity.
- Transmission
 - Hydraulic fluid, Friction elements, Cooling.

This Pinpoint Test is intended to diagnose only the following:

- Harness circuits: CCC, CCS, 4X4 LOW, EPC, OCIL, OCS, SS1, SS2, SIG RTN, TOT, MLP, EPC PWR, and VPWR.
- Processor Assembly (12A650) or (12B565 on 7.3L Diesel).

EEC-IV Pinpoint Test

Pinpoint Test Schematic

E40D VEHICLE HARNESS SCHEMATIC

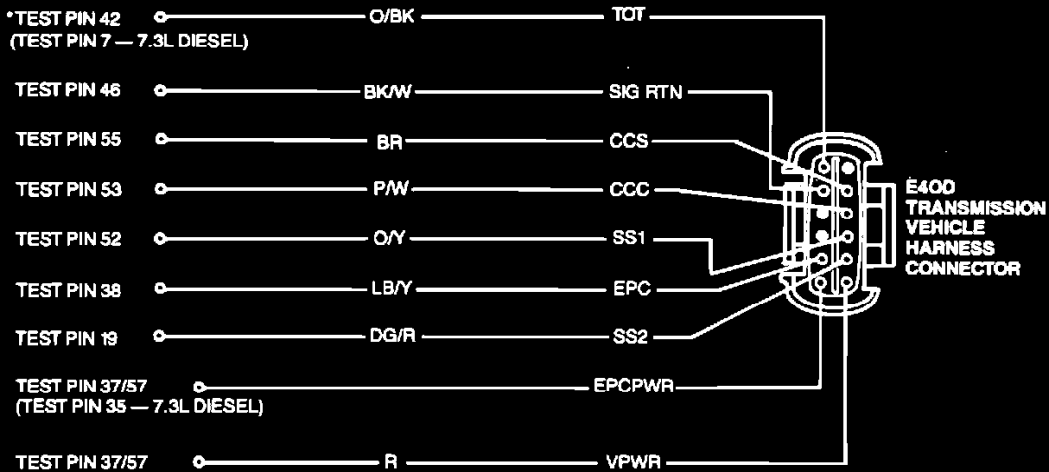

*TEST PINS LOCATED ON BREAKOUT BOX.
 ALL HARNESS CONNECTORS VIEWED INTO MATING SURFACE.

Test Pins 35 & 37/57

EPCPWR

Application	Wire Color
7.3L Diesel	Y/W
4.9L, 5.0L, 5.8L & 7.5L	R or R/W

EEC-IV Pinpoint Test

Pinpoint Test Schematic

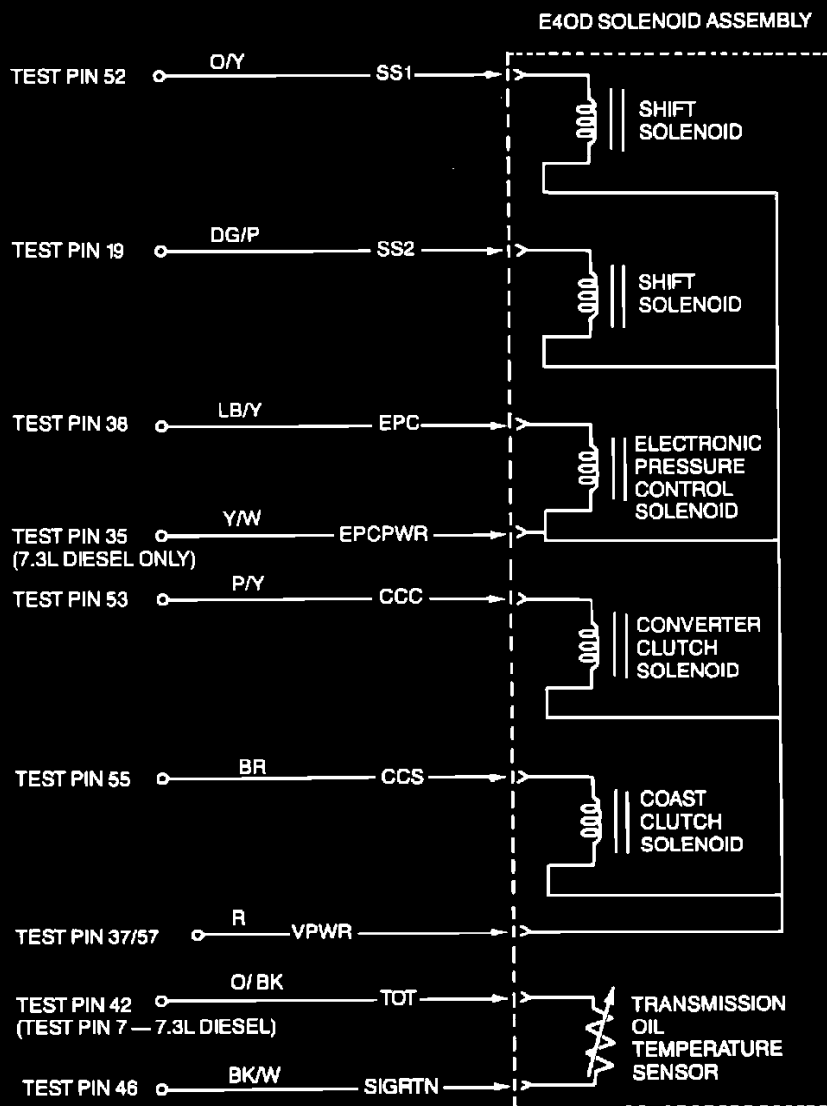

EEC-IV Pinpoint Test

Pinpoint Test Schematic

MANUAL LEVER POSITION (MLP) VEHICLE HARNESS SCHEMATIC

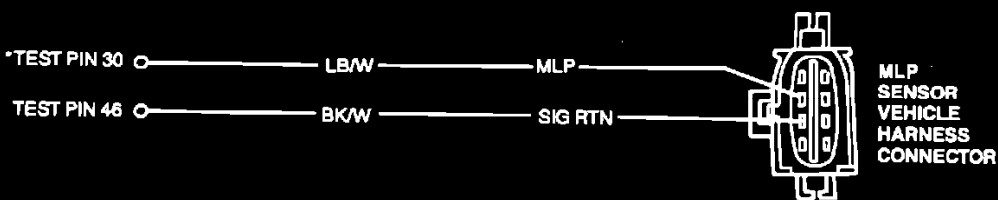

4 x 4 LOW AND OVERDRIVE CANCEL VEHICLE HARNESS SCHEMATIC

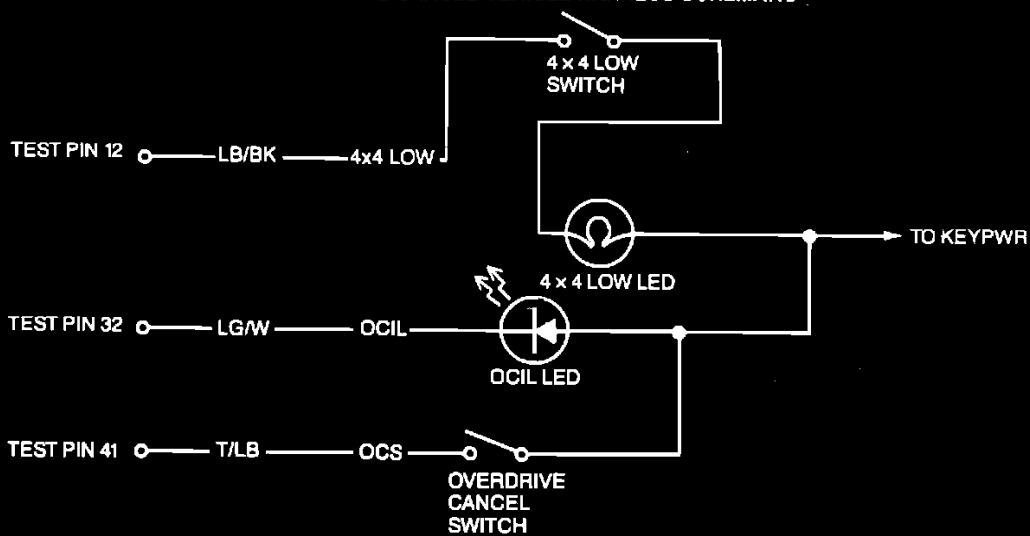

*TEST PINS LOCATED ON BREAKOUT BOX.
ALL HARNESS CONNECTORS VIEWED INTO MATING SURFACE.

EEC-IV Pinpoint Test

TEST STEP		RESULT	ACTION TO TAKE
TC1	SERVICE CODE 67/634 AND 654 CHECK RESISTANCE OF THE MLP SENSOR		
	Service Code 67/634 indicates that the total resistance within the Manual Lever Position (MLP) sensor is out of Self-Test range when the selector lever is in PARK (correct range is 3770 to 4607 ohms).	Yes	GO to TC3 .
	Code 654 indicates that the selector lever was not in Park position during self test.	No	GO to TC2 .
	Possible causes are: <ul style="list-style-type: none"> — Faulty or misadjusted MLP sensor — Open or shorted harness — Faulty processor <ul style="list-style-type: none"> • Key off, wait 10 seconds. • Disconnect processor 60 pin connector. Inspect for damaged or pushed out pins, corrosion, loose wires, etc. Service as necessary. • Install breakout box, leave processor disconnected. • DVOM on 10,000 ohm scale. • Unlock steering column, ignition off. • Measure and record resistance between Test Pin 30 and 46 at the breakout box in each selector position while moving the selector from Park to Low and back to Park position. Refer to MLP Sensor Resistance Specification Table #1. • Is each resistance within specifications? 		

**Manual Lever Position (MLP) Sensor
Resistance Specification Table #1**

Transmission Shift Position	Resistance (ohms)	
	Rmin	Rmax
P	3770	4607
R	1304	1593
N	660	807
D	361	442
2	190	232
1	76	95

EEC-IV Pinpoint Test

TEST STEP		RESULT	ACTION TO TAKE
TC2	CHECK CONTINUITY OF MLP HARNESS CIRCUITS		
<ul style="list-style-type: none"> • Key off. • Disconnect MLP sensor. • Using a mirror, inspect both ends of the transmission harness connector at the MLP sensor for damaged or pushed out pins, corrosion, loose wires, etc. Service as necessary. • Breakout box installed, processor disconnected. • Measure resistance between Test Pin 30 at the breakout box and MLP circuit at the MLP sensor vehicle harness connector. • Measure resistance between Test Pin 46 at the breakout box and SIG RTN circuit at the MLP sensor vehicle harness connector. • Is each resistance less than 5 ohms? 		<p>Yes ▶</p> <p>No ▶</p>	<p>GO to TC3 .</p> <p>SERVICE open circuit(s). REMOVE breakout box. RECONNECT all components. RERUN Quick Test. (Refer to TESTING PROCEDURES/ QUICK TEST AND DIAGNOSTIC AIDS/ DETAILED QUICK TEST PROCEDURES/ KEY ON ENGINE OFF SELF TEST for quick test procedures.)</p>
TC3	CHECK MLP CIRCUIT FOR SHORTS TO POWER OR GROUND		
<ul style="list-style-type: none"> • Key off. • Disconnect MLP sensor. • Breakout box installed, processor disconnected. • Measure resistance between Test Pin 30 and Test Pins 37/57 Test Pin 35 on 7.3L diesel at the breakout box. • Measure resistance between Test Pin 30 and Test Pins 40, 46 and 60 at the breakout box and between Test Pin 30 at the breakout box and chassis ground. • Is each resistance greater than 10,000 ohms? 		<p>Yes ▶</p> <p>No ▶</p>	<p>GO to TC4 .</p> <p>SERVICE short circuit(s). REMOVE breakout box. RECONNECT all components. RERUN Quick Test. (Refer to TESTING PROCEDURES/ QUICK TEST AND DIAGNOSTIC AIDS/ DETAILED QUICK TEST PROCEDURES/ KEY ON ENGINE OFF SELF TEST for quick test procedures.)</p>
TC4	CHECK PROCESSOR OUTPUT VOLTAGE		
<ul style="list-style-type: none"> • Key off. • MLP sensor disconnected. • Breakout box installed. • Connect processor to breakout box. • Key on, engine off. • Measure voltage between Test Pin 30 and Test Pin 46 at the breakout box. • Is voltage between 4.75 and 5.25 volts? 		<p>Yes ▶</p> <p>No ▶</p>	<p>GO to TRANSMISSIONS, CLUTCHES, DIFFERENTIALS, AXLES AND DRIVE SHAFTS for MLP adjustment or service.</p> <p>REPLACE Processor. REMOVE breakout box. RECONNECT MLP sensor. RERUN Quick Test. (Refer to TESTING PROCEDURES/ QUICK TEST AND DIAGNOSTIC AIDS/ DETAILED QUICK TEST PROCEDURES/ KEY ON ENGINE OFF SELF TEST for quick test procedures.)</p>

EEC-IV Pinpoint Test

TEST STEP	RESULT	ACTION TO TAKE
<p>TC10 VERIFY VEHICLE SELF-TEST STATE</p> <p>Service Code 47/633 indicates that the 4x4 Low selector lever is not in the 4x2 or 4x4 High position (observed in Key On Engine Off Self-Test). An early shift in 4x4 High or 4x2 range is likely.</p> <p>Service Code 65/632 indicates that Overdrive Cancel Switch (OCS) is not cycled between the engine I.D. code and the "Goose Test" in Key On Engine Running Self-Test.</p> <p>Service Code 97/631 indicates an Overdrive Cancel Light circuit problem (observed in Key On Engine Off Self-Test).</p> <p>Possible causes are:</p> <ul style="list-style-type: none"> — Faulty 4x4 Low switch, or 4x4 selector lever position — Faulty OCS switch, or switch not cycled during Self-Test — Burned out bulb — Open harness — Shorted harness — Faulty processor <p>• Verify above conditions have been met otherwise, rerun Quick Test. (Refer to TESTING PROCEDURES/QUICK TEST AND DIAGNOSTIC AIDS/DETAILED QUICK TEST PROCEDURES/KEY ON ENGINE OFF SELF TEST for test procedures).</p> <p>• Are any of the above codes present?</p>	<p>Yes</p> <p>No</p>	<p>▶ For code 97/631: GO to TC12 .</p> <p>▶ For codes 47/633, 65/632: GO to TC11 .</p> <p>▶ Unable to duplicate and/or identify fault at this time. For further diagnosis using EEC-IV monitor box, REFER to TESTING PROCEDURES/INTERMITTENT FAULT DIAGNOSIS.</p> <p>▶ All others CLEAR Continuous Memory. RERUN Quick Test. (Refer to TESTING PROCEDURES/QUICK TEST AND DIAGNOSTIC AIDS/DETAILED QUICK TEST PROCEDURES/CONTINUOUS MEMORY CODES for code clearing procedures.) (Refer to TESTING PROCEDURES/QUICK TEST AND DIAGNOSTIC AIDS/DETAILED QUICK TEST PROCEDURES/KEY ON ENGINE OFF SELF TEST for quick test procedures.)</p>
<p>TC11 CYCLE THE APPROPRIATE CIRCUIT: (4x4 LOW OR OVERDRIVE CANCEL)</p> <ul style="list-style-type: none"> • Key off. • Disconnect processor 60 pin connector. Inspect for damaged or pushed out pins, loose wires, etc. Service as necessary. • Install breakout box, leave processor disconnected. • Key on, engine off. <p>For 4x4 LOW circuit:</p> <ul style="list-style-type: none"> — Measure voltage between Test Pin 12 and Test Pin 40 and 60 at the breakout box while moving the 4x4 select lever between 4x2 and 4x4 Low several times. <p>For OCS circuit:</p> <ul style="list-style-type: none"> — Measure voltage between Test Pin 41 and Test Pin 40 and 60 at the breakout box while cycling the overdrive cancel switch several times. <p>• Does the voltage cycle?</p>	<p>Yes</p> <p>No</p>	<p>▶ REPLACE processor. REMOVE breakout box. RERUN Quick Test. (Refer to TESTING PROCEDURES/QUICK TEST AND DIAGNOSTIC AIDS/DETAILED QUICK TEST PROCEDURES/KEY ON ENGINE OFF SELF TEST for quick test procedures.)</p> <p>▶ If you are here for a driveability symptom only: GO to TC14 .</p> <p>▶ If here for a Code: GO to TC12 .</p>

EEC-IV Pinpoint Test

TEST STEP		RESULT	ACTION TO TAKE
TC12	CHECK HARNESS CIRCUIT(S) FOR SHORT TO GROUND		
<ul style="list-style-type: none"> • Key off. • Breakout box installed, processor disconnected. <p>For 4x4 LOW circuit:</p> <ul style="list-style-type: none"> — Disconnect 4x4 Low switch. Inspect both ends of the connector for damaged or pushed out pins, moisture, corrosion, loose wires, etc. Service as necessary. — Measure resistance between Test Pin 12 and Test Pin 40/60 at the breakout box. <p>For overdrive cancel circuits:</p> <ul style="list-style-type: none"> — Disconnect overdrive cancel switch. Inspect both ends of the connector for damaged or pushed out pins, moisture, corrosion, loose wires, etc. Service as necessary. — Measure resistance between Test Pin 41 and Test Pin 40/60 at the breakout box. — Measure resistance between Test Pin 32 and Test Pin 40/60 at the breakout box. <p>Is each resistance greater than 10,000 ohms?</p>		<p>Yes</p> <p>▶</p> <p>No</p> <p>▶</p>	<p>For original code 47/633 or 65/632: GO to TC15</p> <p>For original code 97/631: GO to TC13</p> <p>For original code 47/633: SERVICE short circuit. RERUN Engine Off Self-Test. (Refer to TESTING PROCEDURES/QUICK TEST AND DIAGNOSTIC AIDS/DETAILED QUICK TEST PROCEDURES/KEY ON ENGINE OFF SELF TEST for test procedures).</p> <p>For original code 65/632: SERVICE short circuit. RERUN Engine Running Self-Test. (Refer to TESTING PROCEDURES/QUICK TEST AND DIAGNOSTIC AIDS/DETAILED QUICK TEST PROCEDURES/KEY ON ENGINE RUNNING SELF TEST for test procedures). If code is still present, GO to TC14 .</p> <p>For original code 97/631:SERVICE short circuit. RERUN Engine Off Self-Test. (Refer to TESTING PROCEDURES/QUICK TEST AND DIAGNOSTIC AIDS/DETAILED QUICK TEST PROCEDURES/KEY ON ENGINE OFF SELF TEST for test procedures).</p>
TC13	CHECK KEYPOWER THROUGH OCIL CIRCUIT		
<ul style="list-style-type: none"> • Key on, engine off. • Breakout box installed, processor disconnected. • Measure voltage between Test Pin 32 and Test Pin 40/60 at breakout box. • Is voltage greater than 10.5 volts? 		<p>Yes</p> <p>▶</p> <p>No</p> <p>▶</p>	<p>REPLACE processor. REMOVE breakout box. RERUN Quick Test. (Refer to TESTING PROCEDURES/QUICK TEST AND DIAGNOSTIC AIDS/DETAILED QUICK TEST PROCEDURES/KEY ON ENGINE OFF SELF TEST for test procedures).</p> <p>GO to TC14 .</p>

EEC-IV Pinpoint Test

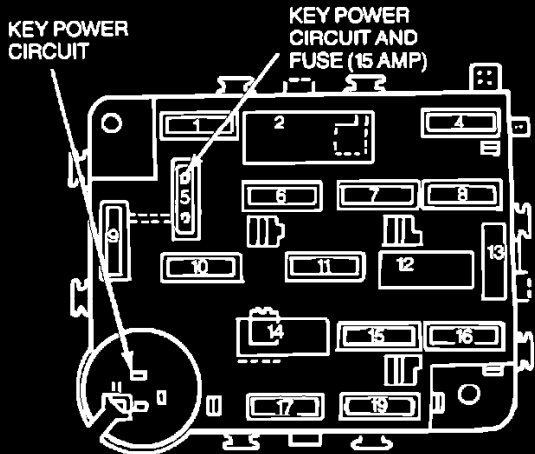
TEST STEP	RESULT	ACTION TO TAKE
TC14 CHECK CONTINUITY OF THE VEHICLE HARNESS CIRCUITS		
<p>NOTE: When entering this Test Step with a symptom or a Self-Test Pass code; first, disconnect processor 60 pin connector. Inspect for damaged pins, pushed out pins, loose wires, etc. Service as necessary.</p> <ul style="list-style-type: none"> • Key off. • Breakout box installed, processor disconnected. • DVOM on diode check position. <p>For 4x4 LOW circuit:</p> <ul style="list-style-type: none"> — Switch disconnected. — Measure the resistance between keypower at the fuse panel shown below (ohmmeter positive probe) and Test Pin 12 at the breakout box (ohmmeter negative probe). <p>For OCIL circuit:</p> <ul style="list-style-type: none"> — Measure the resistance between keypower at the fuse panel shown below (ohmmeter positive probe) and Test Pin 32 at the breakout box (ohmmeter negative probe). <ul style="list-style-type: none"> • Are both resistances less than 5 ohms? 	<p>Yes</p> <p>No</p>	<p>GO to TC15 .</p> <p>Inspect for damaged indicator bulb (4x4 Low LED or OCIL) or damaged fuse in fuse panel. If OK, SERVICE open circuit. REMOVE breakout box. RECONNECT all components. RERUN Quick Test. (Refer to TESTING PROCEDURES/QUICK TEST AND DIAGNOSTIC AIDS/DETAILED QUICK TEST PROCEDURES/ KEY ON ENGINE OFF SELF TEST for quicktest procedures).</p>

EEC-IV Pinpoint Test

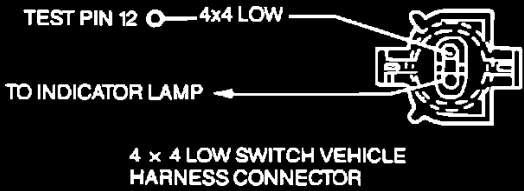
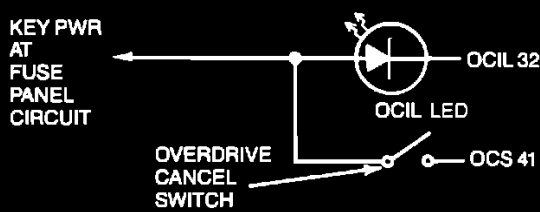
TEST STEP	RESULT	ACTION TO TAKE
<p>TC15 CHECK CONTINUITY OF THE 4X4 LOW OR OVERDRIVE CANCEL SWITCH HARNESS</p> <ul style="list-style-type: none"> • Key off. • Breakout box connected, processor disconnected. • Appropriate switch disconnected. <p>For 4x4 LOW circuit:</p> <ul style="list-style-type: none"> — Measure the resistance between Test Pin 12 at the breakout box and 4x4 low circuit at the 4x4 low switch vehicle harness connector.  <p style="text-align: center;">4 x 4 LOW SWITCH VEHICLE HARNESS CONNECTOR</p> <p>For OCS circuit:</p> <ul style="list-style-type: none"> • Measure the resistance between keypower at the fuse panel shown in Pinpoint Test Step TC14 (ohmmeter positive probe) and the power side of the overdrive cancel switch vehicle harness connector (ohmmeter negative probe). • Measure the resistance between Test Pin 41 at the breakout box and the signal side of the overdrive cancel switch vehicle harness connector.  <ul style="list-style-type: none"> • Are both the resistances less than 5 ohms? 	<p>Yes</p> <p>No</p>	<p>Go to TC16 .</p> <p>SERVICE open circuit(s). REMOVE breakout box. RECONNECT all components. RERUN Quick Test. (Refer to TESTING PROCEDURES/QUICK TEST AND DIAGNOSTIC AIDS/DETAILED QUICK TEST PROCEDURES/KEY ON ENGINE OFF SELF TEST for quick test procedures).</p>

EEC-IV Pinpoint Test

TEST STEP		RESULT	ACTION TO TAKE
TC16	CHECK HARNESS CIRCUIT(S) FOR SHORTS TO POWER	Yes	REPLACE damaged switch, either 4x4L range switch or overdrive cancel switch (OCS) due to service code received. REMOVE breakout box. RECONNECT processor. RERUN Quick Test. (Refer to TESTING PROCEDURES/QUICK TEST AND DIAGNOSTIC AIDS/DETAILED QUICK TEST PROCEDURES/KEY ON ENGINE OFF SELF TEST for test procedures).
		No	SERVICE short circuit(s). REMOVE breakout box. RECONNECT all components. RERUN Quick Test. (Refer to TESTING PROCEDURES/QUICK TEST AND DIAGNOSTIC AIDS/DETAILED QUICK TEST PROCEDURES/KEY ON ENGINE OFF SELF TEST for test procedures).

EEC-IV Pinpoint Test

TEST STEP		RESULT	ACTION TO TAKE																		
TC18	ENTER OUTPUT STATE CHECK (REFER TO QUICK TEST APPENDIX)																				
<p>Service Code(s) 91/621, 92/622, 93/626, 94/627 indicates that the appropriate On/Off solenoid below is out of Self-Test range which may induce harsh, early, or late shifts. Correct range measurement is 9.00 to 14.50 volts when On, and less than 1.00 volt when Off.</p> <p>Possible causes are:</p> <ul style="list-style-type: none"> — Solenoid resistance is out of limits — Open or grounded harness — Faulty processor <table border="1"> <thead> <tr> <th>Solenoid</th> <th>Processor Signal Test Pin</th> <th>K.O.E.O. Self-Test Code</th> </tr> </thead> <tbody> <tr> <td>SS1</td> <td>52</td> <td>91/621</td> </tr> <tr> <td>SS2</td> <td>19</td> <td>92/622</td> </tr> <tr> <td>CCS</td> <td>55</td> <td>93/626</td> </tr> <tr> <td>CCC</td> <td>53</td> <td>94/627</td> </tr> <tr> <td>EPC</td> <td>38</td> <td>998, 99/624</td> </tr> </tbody> </table> <p>SS1 - Shift Solenoid #1 SS2 - Shift Solenoid #2 CCS - Coast Clutch Solenoid CCC - Converter Clutch Solenoid EPC - Electronic Pressure Control</p> <ul style="list-style-type: none"> • Key off. • Disconnect electrical connector on the speed control servo; if equipped. • DVOM/VOM on 20 volt scale. • Connect DVOM negative test lead to STO circuit at Self-Test connector and positive test lead to battery positive. • Jumper STI circuit to SIGNAL RETURN at the Self-Test connector. • Perform Key On Engine Off Self-Test until the completion of the Continuous Test Codes. (Refer to TESTING PROCEDURES/QUICK TEST AND DIAGNOSTIC AIDS/DETAILED QUICK TEST PROCEDURES/KEY ON ENGINE OFF SELF TEST for quick test procedures). • DVOM will indicate less than 1.0 volt when test is completed. • Depress and release the throttle. • Does voltage increase? 		Solenoid	Processor Signal Test Pin	K.O.E.O. Self-Test Code	SS1	52	91/621	SS2	19	92/622	CCS	55	93/626	CCC	53	94/627	EPC	38	998, 99/624	<p>Yes</p> <p>No</p>	<p>▶ REMAIN in Output State Check. GO to TC19</p> <p>▶ DEPRESS throttle to WOT and Release. If STO voltage does not go high, GO to PINPOINT TEST QC,STEPQC1 Leave equipment hooked up</p>
Solenoid	Processor Signal Test Pin	K.O.E.O. Self-Test Code																			
SS1	52	91/621																			
SS2	19	92/622																			
CCS	55	93/626																			
CCC	53	94/627																			
EPC	38	998, 99/624																			

EEC-IV Pinpoint Test

TEST STEP		RESULT	ACTION TO TAKE																	
TC19	CHECK SUSPECT E4OD SOLENOID ELECTRICAL OPERATION																			
<ul style="list-style-type: none"> • Key on, engine off. • Disconnect transmission bulkhead connector at the transmission. • Using a mirror, inspect both ends of the connector for damaged or pushed out pins, corrosion, loose wires, ect. Service as necessary. • Connect DVOM positive test lead to VPWR circuit and negative test lead to the processor signal test pin (refer to table in TC18) at the E4OD transmission vehicle harness connector. • DVOM on 20 volt scale. • While observing DVOM, depress and release the throttle several times to cycle output On and Off. • Does the suspect solenoid output circuit voltage change greater than 1.0 volt? 		<p>Yes ▶</p> <p>No ▶</p>	<p>GO to TRANSMISSION, CLUTCHES, DIFFERENTIALS, AXLES, AND DRIVE SHAFTS for E4OD transmission service.</p> <p>REMOVE jumper. GO to TC20 .</p>																	
TC20	CHECK E4OD TRANSMISSION SOLENOID RESISTANCE																			
<p>Service Code 98/998 indicates that the Electronic Pressure Control solenoid may have an inoperative driver in the processor. Service Code 99/624 indicates that the EPC circuit problem may induce transmission clutch wear and harsh shifts.</p> <ul style="list-style-type: none"> • Key off. • Disconnect processor 60 pin connector. Inspect for damaged or pushed out pins, corrosion, loose wires, etc. Service as necessary. • Install breakout box, leave processor disconnected. • Connect transmission bulkhead connector. • DVOM on 200 ohm scale. • Measure the resistance between Test Pin 37/57 (Test Pin 35 on Diesel) and processor signal Test Pin (refer to table in TC18) at the breakout box. • Is the resistance within specification per the chart below? <table border="1" data-bbox="251 1260 779 1470"> <thead> <tr> <th colspan="2">Ambient Temperature</th> <th rowspan="2">Solenoid</th> <th colspan="2">Resistance (OHMS)</th> </tr> <tr> <th>°C</th> <th>°F</th> <th>MIN</th> <th>MAX</th> </tr> </thead> <tbody> <tr> <td rowspan="2">0 to 110</td> <td rowspan="2">32 to 230</td> <td>SS, CCC, CSS</td> <td>20.50</td> <td>30.00</td> </tr> <tr> <td>EPC</td> <td>4.25</td> <td>6.50</td> </tr> </tbody> </table>		Ambient Temperature		Solenoid	Resistance (OHMS)		°C	°F	MIN	MAX	0 to 110	32 to 230	SS, CCC, CSS	20.50	30.00	EPC	4.25	6.50	<p>Yes ▶</p> <p>No ▶</p>	<p>GO to TC22 .</p> <p>For high resistance: GO to TC21 .</p> <p>For low resistance: GO to TC22 .</p>
Ambient Temperature		Solenoid	Resistance (OHMS)																	
°C	°F		MIN	MAX																
0 to 110	32 to 230	SS, CCC, CSS	20.50	30.00																
		EPC	4.25	6.50																

EEC-IV Pinpoint Test

TEST STEP		RESULT	ACTION TO TAKE
TC21	CHECK CONTINUITY OF E4OD TRANSMISSION SOLENOID HARNESS CIRCUITS		
	<ul style="list-style-type: none"> • Key off. • Breakout box installed, processor disconnected. • Disconnect transmission bulkhead connector at E4OD transmission. • Use a mirror to inspect both ends of the transmission bulkhead connector for damaged or pushed out pins, corrosion, loose wires, ect. Service as necessary. • Measure the resistance between the processor signal test pin (refer to table in TC18) at the breakout box and the same test pin at the E4OD transmission vehicle harness connector. • Measure the resistance between Test Pin 37/57 (Pin 35 on for 7.3L Diesel) at the breakout box and both the EPCPWR pin and the VPWR pin at the E4OD transmission vehicle bulkhead harness connector. (Refer to the first Pinpoint Test Schematic) • Is each resistance less than 5 ohms? 	<p>Yes</p> <p>No</p>	<p>GO to TC22 .</p> <p>SERVICE open circuit. REMOVE breakout box. RECONNECT all components. RERUN Quick Test. (Refer to TESTING PROCEDURES/ QUICK TEST AND DIAGNOSTIC AIDS/ DETAILED QUICK TEST PROCEDURES/ KEY ON ENGINE OFF SELF TEST for quick test procedures.)</p>
TC22	CHECK E4OD SOLENOID HARNESS CIRCUITS FOR SHORTS TO GROUND		
	<ul style="list-style-type: none"> • Key off. • Breakout box installed, processor disconnected. • Transmission bulkhead connector disconnected. • Measure the resistance between the processor signal test pin (refer to table in TC18) and Test Pins 40, 46 and 60 at the breakout box and between the processor signal test pin at the breakout box and chassis ground. • Is each resistance greater than 10,000 ohms? 	<p>Yes</p> <p>No</p>	<p>GO to TC23 .</p> <p>SERVICE short circuit(s). REMOVE breakout box. RECONNECT all components. RERUN Quick Test. (Refer to TESTING PROCEDURES/ QUICK TEST AND DIAGNOSTIC AIDS/ DETAILED QUICK TEST PROCEDURES/ KEY ON ENGINE OFF SELF TEST for quick test procedures.)</p>
TC23	CHECK E4OD SOLENOID HARNESS CIRCUITS FOR SHORTS TO POWER		
	<ul style="list-style-type: none"> • Key off. • Breakout box installed, processor disconnected. • Transmission bulkhead connector disconnected. • Measure the resistance between the processor signal test pin (refer to table in TC18) and Test Pins 37 and 57 (Pin 35 on Diesel) at the breakout box. • Is each resistance greater than 10,000 ohms? 	<p>Yes</p> <p>No</p>	<p>GO to TC24 .</p> <p>SERVICE short circuit(s). REMOVE breakout box. RECONNECT all components. RERUN Quick Test. (Refer to TESTING PROCEDURES/ QUICK TEST AND DIAGNOSTIC AIDS/ DETAILED QUICK TEST PROCEDURES/ KEY ON ENGINE OFF SELF TEST for quick test procedures.)</p>

EEC-IV Pinpoint Test

TEST STEP	RESULT	ACTION TO TAKE
<p>TC24 CHECK VOLTAGE OF VPWR TO E4OD TRANSMISSION SOLENOIDS</p> <ul style="list-style-type: none"> • Key off. • Breakout box installed. • Connect processor to breakout box. • Transmission bulkhead connector disconnected. • Key on, engine off. • Measure voltage between VPWR circuits (Test Pins 37 and 57, EPC PWR Pin 35 on diesel) at the E4OD transmission vehicle harness connector and chassis ground or negative battery post. • Are both voltages greater than 10.5 volts? 	<p>Yes</p> <p>No</p>	<p>GO to TC25 .</p> <p>REPLACE processor. REMOVE breakout box. RECONNECT all components. RERUN Quick Test. (Refer to TESTING PROCEDURES/ QUICK TEST AND DIAGNOSTIC AIDS/ DETAILED QUICK TEST PROCEDURES/ KEY ON ENGINE OFF SELF TEST for quick test procedures.)</p>
<p>TC25 CHECK SOLENOID DRIVER SIGNAL</p> <p>Requires standard non-power 12 volt lamp.</p> <ul style="list-style-type: none"> • Key off. • Breakout box installed, processor connected. • Bulkhead connector disconnected. • Connect test lamp between VPWR Test Pin 37 or 57 (EPC PWR Pin 35 on Diesel) and processor signal test pin (refer to table in TC18) at the breakout box. • Key on, engine off. <p>NOTE: For Pins 38 (EPC) and 52 (SS1), the lamp will be "ON" with key On, ignore this; only concern is the light during Self-Test.</p> <ul style="list-style-type: none"> • Now initiate Key On Engine Off Self-Test. Ignore codes induced in this test. <p>(Refer to TESTING PROCEDURES/QUICK TEST AND DIAGNOSTIC AIDS/DETAILED QUICK TEST PROCEDURES/ KEY ON ENGINE OFF SELFTEST for quick test procedures).</p> <ul style="list-style-type: none"> • Does test lamp flash momentarily when Self-Test is initiated and then stay off? 	<p>Yes</p> <p>No</p>	<p>GO to TRANSMISSIONS, CLUTCHES, DIFFERENTIALS, AXLES, AND DRIVE SHAFTS for E4OD transmission service.</p> <p>If test lamp never flashed: Solenoid Driver open in processor. REPLACE processor. REMOVE breakout box. RECONNECT all components. RERUN Quick Test. (Refer to TESTING PROCEDURES/ QUICK TEST AND DIAGNOSTIC AIDS/ DETAILED QUICK TEST PROCEDURES/ KEY ON ENGINE OFF SELF TEST for quick test procedures.)</p> <p>If test lamp is always on: Solenoid Driver shorted to ground in processor. REPLACE processor. REMOVE breakout box. RECONNECT all components. RERUN Quick Test. (Refer to TESTING PROCEDURES/ QUICK TEST AND DIAGNOSTIC AIDS/ DETAILED QUICK TEST PROCEDURES/ KEY ON ENGINE OFF SELF TEST for quick test procedures.)</p>

EEC-IV Pinpoint Test

TEST STEP		RESULT	ACTION TO TAKE
TC30	SERVICE CODE 26/636: CHECK TRANSMISSION OIL OPERATING TEMPERATURE		
<p>Service Code 26/636 indicates that the Transmission Oil Temperature (TOT) sensor is out of Self-Test range.</p> <p>Correct range of measurement is 0.21 to 3.50 volts.</p> <p>Possible causes are:</p> <ul style="list-style-type: none"> — TOT resistance is out of limits — Faulty processor • Drive vehicle through normal shift cycle in city traffic for 20 to 30 minutes to bring transmission oil temperature to at least 50 degrees Fahrenheit. If outside ambient temperature is less than -2 degrees Fahrenheit the vehicle may require a longer drive warm-up time. • Rerun Quick Test. <p>(Refer to TESTING PROCEDURES/QUICK TEST AND DIAGNOSTIC AIDS/DETAILED QUICK TEST PROCEDURES/KEY ON ENGINE OFF SELF TEST for quick test procedures).</p> <p>• Is code 26 or 636 present?</p>		<p>Yes</p> <p>No</p>	<p>GO to TC31 .</p> <p>SERVICE other codes as necessary.</p>
TC31	CHECK FOR VREF AT THROTTLE POSITION SENSOR		
<ul style="list-style-type: none"> • Refer to schematic below • Key off. • Disconnect processor 60 pin connector. Inspect for damaged or pushed out pins, corrosion, loose wires, etc. Service as necessary. • Install breakout box and connect processor to breakout box. • Disconnect TP sensor. Inspect both ends of the connector for damaged or pushed out pins, moisture, corrosion, loose wires, etc. Service as necessary. • Key on, engine off. • Measure voltage between VREF and SIG RTN circuits at the TP sensor vehicle harness connector. • Is voltage between 4.0 and 6.0 volts? 		<p>Yes</p> <p>No</p>	<p>RECONNECT TP sensor. GO to TC32 .</p> <p>GO to PINPOINT TEST C, STEP C1.</p>

EEC-IV Pinpoint Test

Pinpoint Test Schematic

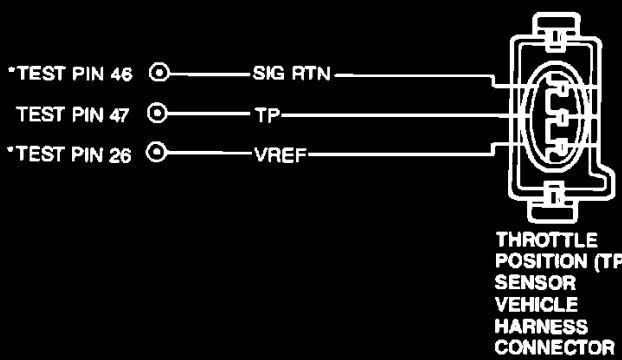

*TEST PINS LOCATED ON BREAKOUT BOX.
ALL HARNESS CONNECTORS VIEWED INTO MATING SURFACE.

EEC-IV Pinpoint Test

TEST STEP		RESULT	ACTION TO TAKE
TC32	CHECK RESISTANCE OF TOT SENSOR		
<p>NOTE: Transmission oil temperature may have cooled down. The oil temperature must be at a minimum of 50 degrees Fahrenheit before taking TOT resistance measurement.</p> <ul style="list-style-type: none"> • Key off. • Breakout box installed. • Disconnect processor. • DVOM on 200,000 ohm scale. • Key on, engine off. • Carefully touch the transmission oil pan on the driver's side, away from the exhaust system. The transmission oil pan should be warm to the touch. As a guide, "warm to the touch" is about 41-70° degrees C (105-158° degrees F). • Measure the resistance between Test Pin 42 (Test Pin 7 on 7.3L diesel) and Test Pin 46 at the breakout box. Refer to TOT Sensor Resistance Specification Table #2. • Is the resistance within specification for the appropriate transmission oil temperature? 		<p>Yes</p> <p>No</p>	<p>GO to TC33 .</p> <p>REMOVE breakout box. RECONNECT all components. GO to TRANSMISSIONS, CLUTCHES, DIFFERENTIALS, AXLES AND DRIVE SHAFTS for transmission service of the TOT sensor.</p>

**Transmission Oil Temperature (TOT) Sensor
Resistance Specification Table #2**

Transmission Oil Temperature		Resistance Range (ohms)
°C	°F	
0 - 20	32 - 58	100K - 37K
21 - 40	59 - 104	37K - 16K
41 - 70	105 - 158	16K - 5K
71 - 90	159 - 194	5K - 2.7K
91 - 110	195 - 230	2.7K - 1.5K
111 - 130	231 - 266	1.5K - 0.8K

TEST STEP		RESULT	ACTION TO TAKE
TC33	CHECK TOT SENSOR RESISTANCE SHIFT VS OIL TEMPERATURE SHIFT		
<p>NOTE: The TOT sensor may sometimes appear to be within the appropriate resistance specification (0.8K to 100K ohms) and not be in the corresponding temperature range. This increases the chances of not being able to determine the integrity of the TOT sensor.</p> <ul style="list-style-type: none"> • Check again for the transmission temperature by touching the transmission oil pan. <ul style="list-style-type: none"> — If it is cold, run the vehicle for a short time to heat it up. — If it is too hot to touch, let the vehicle and transmission cool down. • Measure the TOT sensor resistance again and compare it to the resistance received in Pinpoint Test Step TC32 . • Did the resistance decrease upon heating the transmission or increase upon cooling down the transmission significantly? 		<p>Yes</p> <p>No</p>	<p>REPLACE processor. REMOVE breakout box. RERUN Quick Test. (Refer to TESTING PROCEDURES/QUICK TEST AND DIAGNOSTIC AIDS/DETAILED QUICK TEST PROCEDURES/KEY ON ENGINE OFF SELF TEST for quick test procedures).</p> <p>REMOVE breakout box. RECONNECT processor. GO to TRANSMISSIONS, CLUTCHES, DIFFERENTIALS, AXLES, AND DRIVE SHAFTS for TOT sensor replacement procedures.</p>
TC40	SERVICE CODE 56/637: ATTEMPT TO GENERATE CODE 66/638		
<p>Service Code 56/637 indicates that the Transmission Oil Temperature (TOT) sensor signal is greater than Self-Test maximum value of 4.80 volts.</p> <p>Possible causes are:</p> <ul style="list-style-type: none"> — Faulty TOT sensor — Open harness — Faulty processor • Key off. • Disconnect transmission bulkhead connector at TOT sensor. Inspect for damaged or pushed out pins, corrosion, loose wires, etc. Service as necessary. • Insert a jumper wire between TOT circuit and SIG RTN circuit at the E4OD transmission vehicle harness connector. • Run Key On Engine Off Self-Test. (Refer to TESTING PROCEDURES/QUICK TEST AND DIAGNOSTIC AIDS/DETAILED QUICK TEST PROCEDURES/KEY ON ENGINE OFF SELF TEST for quick test procedures.) • If code 66 or 638 is present, ignore other codes? 		<p>Yes</p> <p>No</p>	<p>REMOVE jumper wire. GO to TRANSMISSIONS, CLUTCHES, DIFFERENTIALS, AXLES, AND DRIVE SHAFTS, for transmission service of the TOT sensor.</p> <p>REMOVE jumper wire. GO to TC41 .</p>

EEC-IV Pinpoint Test

TEST STEP		RESULT	ACTION TO TAKE
TC41	CHECK CONTINUITY OF TOT AND SIG RTN CIRCUITS	Yes	REPLACE processor. REMOVE breakout box. RECONNECT all components. RERUN Quick Test. (Refer to TESTING PROCEDURES/QUICK TEST AND DIAGNOSTIC AIDS/DETAILED QUICK TEST PROCEDURES/KEY ON ENGINE OFF SELF TEST for test procedures).
	<ul style="list-style-type: none"> • Key off. • Transmission bulkhead connector disconnected. • Disconnect processor 60 pin connector. Inspect for damaged or pushed out pins, corrosion, loose wires, etc. Service as necessary. • Install breakout box, leave processor disconnected. • Measure the resistance between TOT circuit at the E4OD transmission vehicle harness connector and Test Pin 42 (or Test Pin 7 on 7.3L diesel) at the breakout box. • Measure the resistance between SIG RTN circuit at the E4OD transmission vehicle harness connector and Test Pin 46 at the breakout box. • Are both resistances less the 5 ohms? 	No	SERVICE open circuit(s). REMOVE breakout box. RECONNECT all components. RERUN Quick Test. (Refer to TESTING PROCEDURES/QUICK TEST AND DIAGNOSTIC AIDS/DETAILED QUICK TEST PROCEDURES/KEY ON ENGINE OFF SELF TEST for test procedures).
TC50	SERVICE CODE 66/638: ATTEMPT TO GENERATE CODE 56/637	Yes	GO to TRANSMISSIONS, CLUTCHES, DIFFERENTIALS, AXLES, AND DRIVE SHAFTS for transmission service of the TOT sensor.
	<p>Service Code 66/638 indicates that the Transmission Oil Temperature (TOT) sensor signal is less than the Self-Test minimum value of 0.15 volts.</p> <p>Possible causes are:</p> <ul style="list-style-type: none"> — Faulty TOT sensor — Grounded harness — Faulty processor <ul style="list-style-type: none"> • Key off. • Disconnect transmission bulkhead connector at the TOT sensor. Inspect for damaged or pushed out pins, corrosion, loose wires, etc. Service as necessary. • Run Key On Engine Off Self-Test. (Refer to TESTING PROCEDURES/QUICK TEST AND DIAGNOSTIC AIDS/DETAILED QUICK TEST PROCEDURES/KEY ON ENGINE OFF SELF TEST for quick test procedures.) • If code 56 or 637 is present, ignore other codes? 	No	GO to TC51 .

EEC-IV Pinpoint Test

TEST STEP		RESULT	ACTION TO TAKE
TC51	CHECK FOR VREF AT THROTTLE POSITION SENSOR		
	<ul style="list-style-type: none"> • Refer to schematic below. • Key off. • Disconnect processor 60 pin connector. Inspect for damaged or pushed out pins, corrosion, loose wires, etc. Service as necessary. • Install breakout box and connect processor to breakout box. • Disconnect TP sensor. Inspect both ends of the connector for damaged or pushed out pins, moisture, corrosion, loose wires, etc. Service as necessary. • Key on, engine off. • Measure voltage between VREF and SIG RTN circuits at the TP sensor vehicle harness connector. • Is voltage between 4.0 and 6.0 volts? 	<p>Yes ▶</p> <p>No ▶</p>	<p>RECONNECT TP sensor. GO to TC52 .</p> <p>GO to PINPOINT TEST C, STEP C1.</p>
TC52	CHECK TOT CIRCUIT FOR SHORTS TO GROUND		
	<ul style="list-style-type: none"> • Key off. • Transmission bulkhead connector disconnected. • Breakout box installed. • Disconnect processor. • Measure the resistance between Test Pin 42 (or Test Pin 7 on 7.3L diesel) and Test Pins 40, 46 and 60 at the breakout box. • Is each resistance greater than 10,000 ohms? 	<p>Yes ▶</p> <p>No ▶</p>	<p>REPLACE processor. REMOVE breakout box. RECONNECT all components. RERUN Quick Test. (Refer to TESTING PROCEDURES/QUICK TEST AND DIAGNOSTIC AIDS/DETAILED QUICK TEST PROCEDURES/ KEY ON ENGINE OFF SELF TEST for quick test procedures).</p> <p>SERVICE short circuit. REMOVE breakout box. RECONNECT all components. RERUN Quick Test. (Refer to TESTING PROCEDURES/QUICK TEST AND DIAGNOSTIC AIDS/DETAILED QUICK TEST PROCEDURES/ KEY ON ENGINE OFF SELF TEST for quick test procedures).</p>

EEC-IV Pinpoint Test

Pinpoint Test Schematic

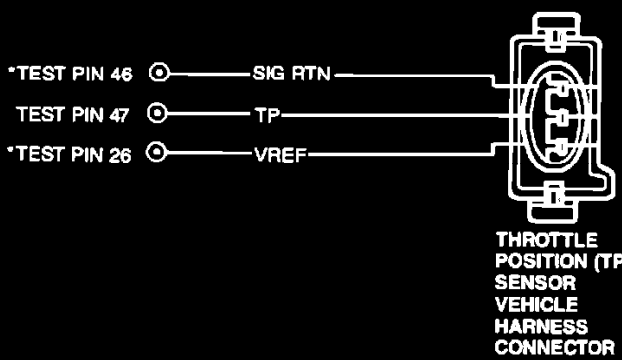

*TEST PINS LOCATED ON BREAKOUT BOX.
 ALL HARNESS CONNECTORS VIEWED INTO MATING SURFACE.

EEC-IV Pinpoint Test

TEST STEP		RESULT	ACTION TO TAKE
TC90	MLP, TOT SENSOR AND E4OD SOLENOID DRIVE CYCLE		
	<ul style="list-style-type: none"> Verify that all components are connected. Bring engine to operating temperature. Verify correct transmission fluid level. Run Key On Engine Off Self-Test and record Continuous Memory Codes. (Refer to TESTING PROCEDURES/QUICK TEST AND DIAGNOSTIC AIDS/DETAILED QUICK TEST PROCEDURES/KEY ON ENGINE OFF SELF TEST for quick test procedures.) <ul style="list-style-type: none"> If codes 49/617, 59/618 or 69/619 are present..... If codes 49/617, 59/618 or 69/619 are not present, record and clear Continuous Memory Self-Test Codes. (Refer to TESTING PROCEDURES/QUICK TEST AND DIAGNOSTIC AIDS/DETAILED QUICK TEST PROCEDURES/KEY ON ENGINE RUNNING SELF TEST for test procedures.) With transmission in D range, and OD enable set: <ul style="list-style-type: none"> Drive in city traffic with moderate to heavy accelerations. Hold throttle opening steady while transmission is shifting through all four gears, then hold throttle for an additional 15 seconds. Apply brakes on coming to a stop and remain stopped for 20 seconds, then repeat drive step above four to five times. Rerun Key On Engine Off Self-Test and record Continuous Memory Codes. (Refer to TESTING PROCEDURES/QUICK TEST AND DIAGNOSTIC AIDS/DETAILED QUICK TEST PROCEDURES/KEY ON ENGINE OFF SELF TEST for quick test procedures) <ul style="list-style-type: none"> For code 11/111..... For code 29/452..... For code 56/637, 62/628, 66/638, 67/634 and 99/624..... 		GO to TC96 .
			GO to TC91 .
			GO to PINPOINT TEST DP, STEP DP1.
			GO to TC92 .
TC91	ATTEMPT TO GENERATE CONTINUOUS MEMORY CODE 56/637, 62/628, 66/638, 67/634 and 99/624		
	<p>NOTE: Before performing any procedures in this test step you must complete the drive cycle outlined above.</p> <ul style="list-style-type: none"> Take the vehicle on the road again and drive on a rough road for 15 minutes to simulate road shock. Observe MIL LED while driving for indication of fault. Does the MIL flash on and off? 	Yes	RETURN vehicle to repair area. GO to TC92
		No	Unable to duplicate fault. Testing is completed.

EEC-IV Pinpoint Test

TEST STEP		RESULT	ACTION TO TAKE
TC92	CHECK CIRCUIT USING KEY ON ENGINE OFF CONTINUOUS MONITOR MODE	Yes	DISCONNECT and INSPECT connectors. If terminals are good, GO to TRANSMISSIONS, CLUTCHES, DIFFERENTIALS, AXLES, AND DRIVE SHAFTS for MLP TOT sensor(s) or E4OD solenoid service CLEAR Continuous Memory Code(s) (Refer to TESTING PROCEDURES/QUICK TEST AND DIAGNOSTIC AIDS/DETAILED QUICK TEST PROCEDURES/CONTINUOUS MEMORY CODES for test procedures) Continuous Memory Code testing is complete.
	<ul style="list-style-type: none"> Enter Key On Engine Off Continuous Monitor mode. Refer to Quick Test Appendix. (Refer to TESTING PROCEDURES/QUICK TEST AND DIAGNOSTIC AIDS/DETAILED QUICK TEST PROCEDURES/KEY ON ENGINE OFF SELF TEST for quick test procedures.) Observe VOM or STAR LED for indication of a fault while performing the following: For MLP sensor (code 67/634): <ul style="list-style-type: none"> Lightly tap on MLP sensor (simulate road shock). Wiggle connector at MLP sensor. For E4OD transmission solenoids (codes 62/628 or 99/624) and Transmission Oil Temperature (TOT) sensor (Codes 56/637 or 66/638): <ul style="list-style-type: none"> Wiggle transmission bulkhead connector. <p>Is a fault indicated?</p>	No	GO to TC93 .
TC93	CHECK EEC-IV VEHICLE HARNESS	Yes	ISOLATE fault and SERVICE as necessary. CLEAR Continuous Memory Code(s) (Refer to TESTING PROCEDURES/QUICK TEST AND DIAGNOSTIC AIDS/DETAILED QUICK TEST PROCEDURES/CONTINUOUS MEMORY CODES for test procedures. RERUN Quick Test.
	<ul style="list-style-type: none"> Still in Key On Engine Off Continuous Monitor mode. Observe VOM or STAR LED for a fault indication while performing the following: <ul style="list-style-type: none"> Referring to the illustration in TC94, grasp the harness closest to the sensor/ transmission connector. Wiggle, shake or bend a small section of the EEC-IV system vehicle harness while working your way to the dash panel, processor, and transmission. <p>Is a fault indicated?</p>	No	GO to TC95 .

EEC-IV Pinpoint Test

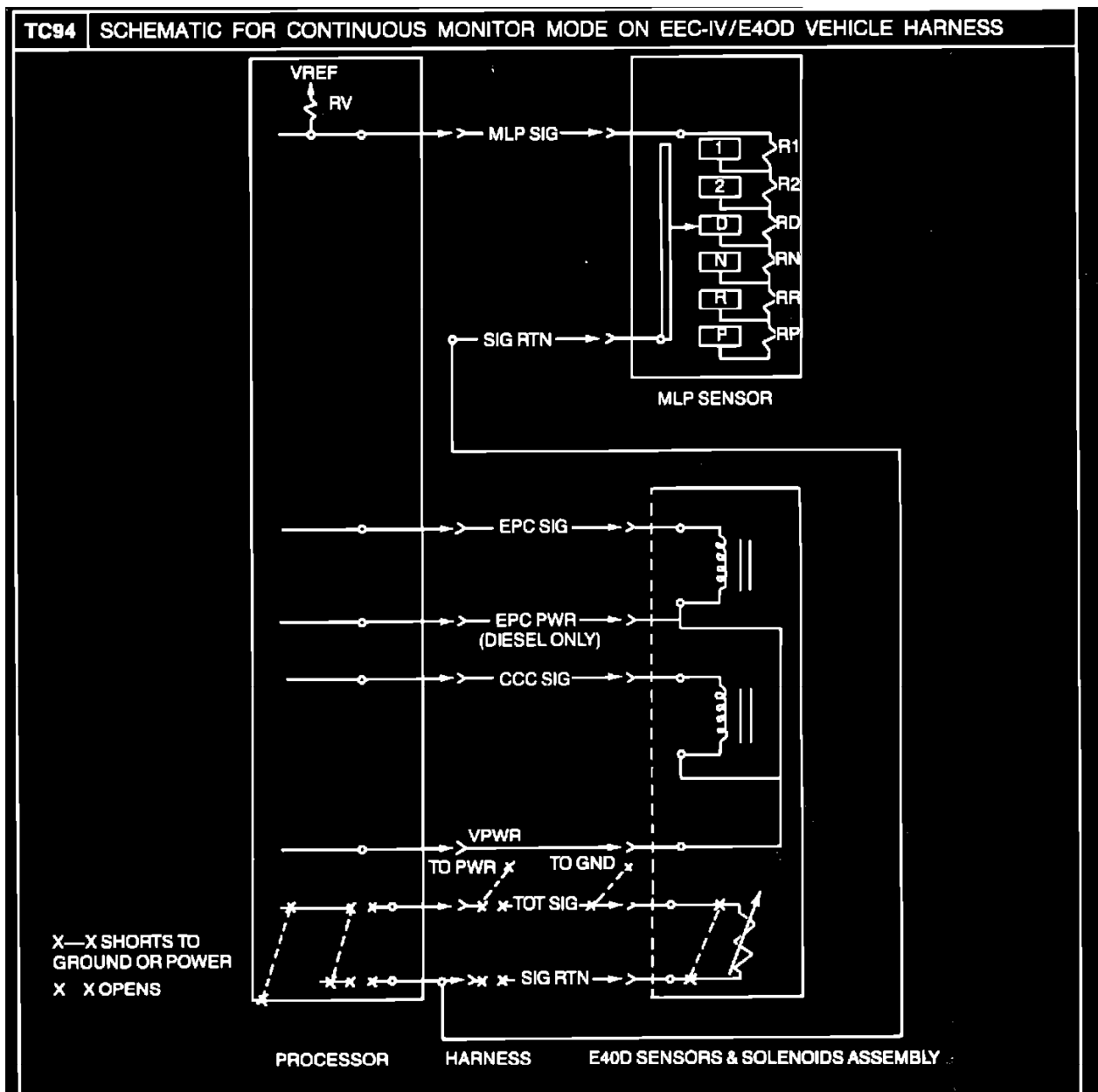

EEC-IV Pinpoint Test

TEST STEP		RESULT	ACTION TO TAKE
TC95	CHECK PROCESSOR AND HARNESS CONNECTORS	Yes	<p>Unable to duplicate and/or identify fault at this time . For further diagnosis using the EEC-IV Monitor box. REFER to TESTING PROCEDURES/INTERMITTENT FAULT DIAGNOSIS.</p> <p>All others, CLEAR Continuous Memory RERUN Quick Test.</p> <p>(Refer to TESTING PROCEDURES/ QUICK TEST AND DIAGNOSTIC AIDS/ DETAILED QUICK TEST PROCEDURES/ CONTINUOUS MEMORY CODES for code clearing procedures.)</p> <p>(Refer to TESTING PROCEDURES/ QUICK TEST AND DIAGNOSTIC AIDS/ DETAILED QUICK TEST PROCEDURES/ KEY ON ENGINE OFF SELF TEST for quick test procedures.)</p>
		No	<p>SERVICE as necessary. CLEAR Continuous Memory Code(s). RERUN Quick Test.</p> <p>(Refer to TESTING PROCEDURES/ QUICK TEST AND DIAGNOSTIC AIDS/ DETAILED QUICK TEST PROCEDURES/ CONTINUOUS MEMORY CODES for code clearing procedures.)</p> <p>(Refer to TESTING PROCEDURES/ QUICK TEST AND DIAGNOSTIC AIDS/ DETAILED QUICK TEST PROCEDURES/ KEY ON ENGINE OFF SELF TEST for quick test procedures.)</p>
TC96	CONTINUOUS MEMORY CODES 49/617, 59/618, 69/619:	Yes	<p>GO to TESTING PROCEDURES/ QUICK TESTS AND DIAGNOSTIC AIDS/QUICK TEST CODES AND DEFINITIONS.</p>
		No	<p>GO to TC97 .</p>
<p>Service Code(s) 49/617, 59/618, 69/619 indicates that the transmission went through two improper shifts in an upward gear range (1-2 gear, 2-3 gear, or 3-4 gear) consecutively over a drive time period.</p> <p>Possible causes are:</p> <ul style="list-style-type: none"> — Intermittent harness continuity — MLP sensor out of adjustment — Stuck shift solenoid shift valves — Worn friction elements <ul style="list-style-type: none"> • Rerun Key On Engine Off Self-Test. (Refer to TESTING PROCEDURES/QUICK TEST AND DIAGNOSTIC AIDS/DETAILED QUICK TEST PROCEDURES/ KEY ON ENGINE OFF SELF TEST for test porcedures) • Do any other codes appear in Key On Engine Off Self-Test In addition to the Continuous Memory Codes 49/617, 59/618 or 69/619? 			

EEC-IV Pinpoint Test

TEST STEP		RESULT	ACTION TO TAKE
TC97	CHECK CIRCUITS USING KEY ON ENGINE OFF CONTINUOUS MONITOR MODE	Yes	DISCONNECT and INSPECT connectors and for loose wires. SERVICE as necessary. CLEAR Continuous Memory Code(s). Refer to TESTING PROCEDURES/ QUICK TEST ND DIAGNOSTIC AIDS/DETAILED QUICK TEST PROCEDURES/CONTINUOUS MEMORY CODES for test procedures. Continuous Memory Code testing is completed.
	<ul style="list-style-type: none"> • Enter Key On Engine Off Continuous Monitor mode. (Refer to TESTING PROCEDURES/QUICK TEST AND DIAGNOSTIC AIDS/DETAILED QUICK TEST PROCEDURES/CONTINUOUS MEMORY CODES for test procedures.) • Observe VOM or STAR LED for indication of a fault while performing the following: <ul style="list-style-type: none"> — Wiggle, shake or bend a small section of the EEC-IV system vehicle harness while working your way to the dash panel, processor, and transmission bulkhead connector. • Is a fault indicated? 	No	GO to TRANSMISSIONS, CLUTCHES, DIFFERENTIALS, AXLES, AND DRIVE SHAFTS for E4OD transmission service.

EEC-IV Pinpoint Test