

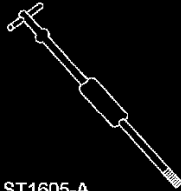

Seals and Gaskets: Service and Repair

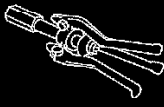

Power Transfer Unit (PTU) Seal

Power Transfer Unit (PTU) Seal

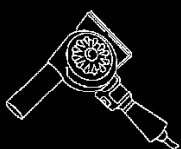
Special Tool(s)	
 <p>ST1605-A</p>	<p>Slide Hammer 100-001 (T50T-100-A)</p>
 <p>ST1200-A</p>	<p>Bearing Cup Puller 308-047 (T77F-1102-A)</p>
 <p>ST2571-A</p>	<p>Installer, PTU Drive Gear Outer Oil Seal 308-430</p>
 <p>ST2572-A</p>	<p>Installer, Halfshaft Oil Seal 308-431</p>
 <p>ST1073-A</p>	<p>Heat Gun 107-R0300</p>

(Continued)

Special Tool(s) (Part 1)

Special Tool(s)	
 <p>ST1255-A</p>	<p>Handle 205-153 T80T-4000-W</p>
 <p>ST1568-A</p>	<p>Remover/Installer, Bearing Cup 204-038 T77F-1217-A</p>

Special Tool(s) (Part 2)

Removal

1. With the vehicle in NEUTRAL, position it on a hoist. For additional information, refer to Maintenance/Service and Repair.
2. Remove the intermediate shaft.
3. **NOTE:** The seal deflector will be damaged during removal. Be careful not to damage the cover seal directly behind the seal deflector.

Remove the seal deflector.

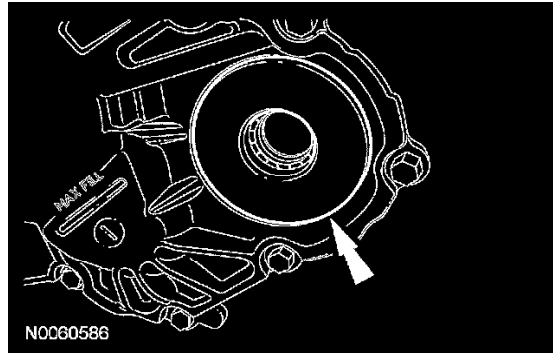

4. **NOTE:** The removal of the intermediate shaft can unseat the seal. Check the seal before installing the special tools.

Using the special tools, remove the intermediate shaft seal.

^ Clean the area around the seal deflector and seal.

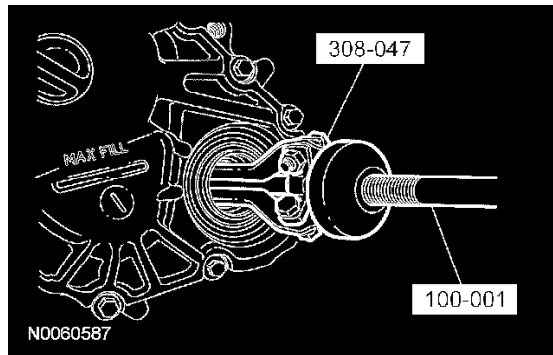

5. If necessary, remove the cover seal.

Installation

1. If necessary, install a new cover seal. Using the special tools, seat the cover seal.

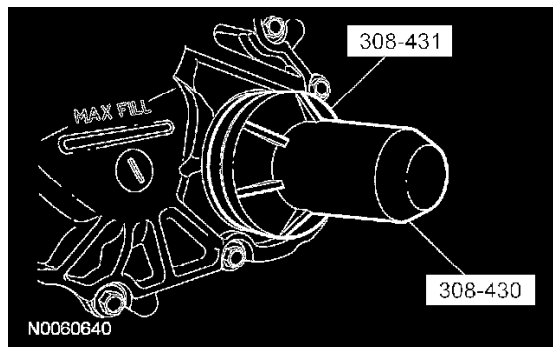

2. Using the special tools, install a new intermediate shaft seal.

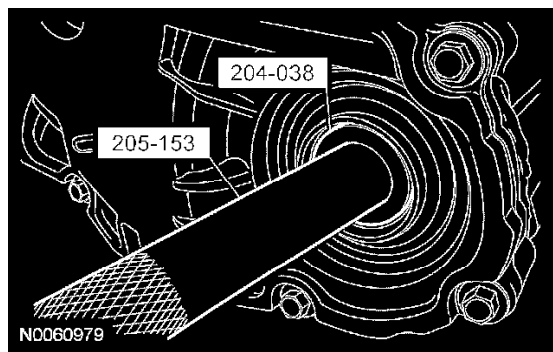

3. **NOTE:** Do not overheat (melt) the seal deflector. If the deflector is damaged, a new one must be used.

Using a suitable heat gun, heat the new seal deflector. Concentrate the heat across the back of the deflector near the white colored tabs. Install the seal deflector immediately after heating.

- ^ If necessary, use special tools 308-430 and 308-431 to seat the seal deflector. Make sure the deflector is fully seated and there are no cracks on the face or inner diameter white colored tab.
- ^ An alternate method to heat the seal deflector, place the deflector in boiling water for **3 to 5 minutes**. Dry off deflector and install.
- ^ Make sure the deflector is completely seated all the way around.

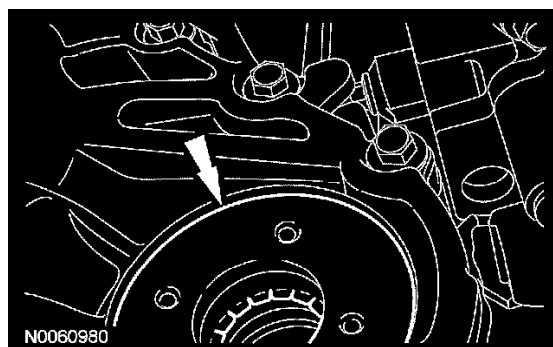

4. Install the intermediate shaft.