

Computers and Control Systems: Pinpoint Tests

Test DC: Mass Air Flow (MAF) Sensor

DC: Mass Air Flow (MAF) Sensor Introduction

Note

This Pinpoint Test is intended to diagnose the following:

- Mass Air Flow (MAF) Sensor (12B579)
- Harness Circuits: MAF SIG, MAF RTN, Vehicle Power (VPWR), Power Ground (PWR GND), IAT and SIG RTN
- Powertrain Control Module (PCM) (12A650)

Pinpoint Test Schematics and Connectors

Focus, 2.0L Cougar

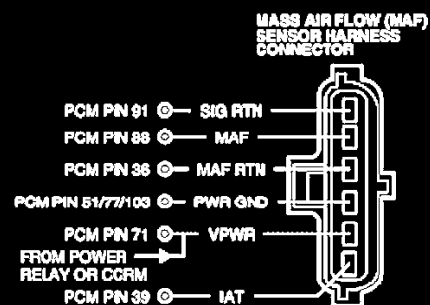

NOTE: ALL HARNESS CONNECTORS ARE VIEWED INTO MATING SURFACE

A0009817

Mustang, Taurus/Sable, Windstar, Ranger, Escape, Explorer Sport/Sport Trac, Econoline, Excursion, 5.4L/6.8L F250/F350/450 (NOTE: For Mustang, PCM PWR GND Pin 76 replaces Pin 77.)

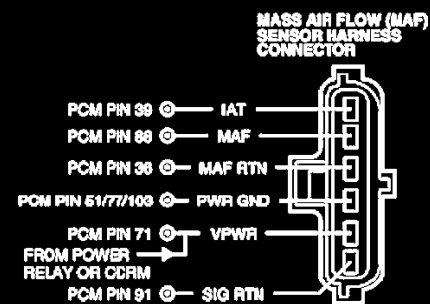

NOTE: ALL HARNESS CONNECTORS ARE VIEWED INTO MATING SURFACE

A0009816

Note, Schematics, And Connectors

LS6/LS8, Thunderbird, Explorer/Mountaineer

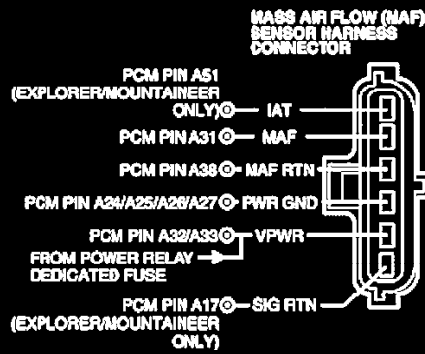

NOTE: ALL HARNESS CONNECTORS ARE VIEWED INTO MATING SURFACE

A0027478

Escort (4V)



NOTE: ALL HARNESS CONNECTORS ARE VIEWED INTO MATING SURFACE

A0009689

All Others

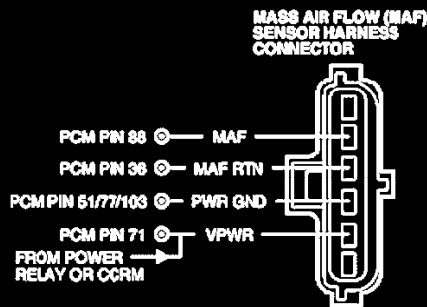

NOTE: ALL HARNESS CONNECTORS ARE VIEWED INTO MATING SURFACE

A0009688

Escort (2V)

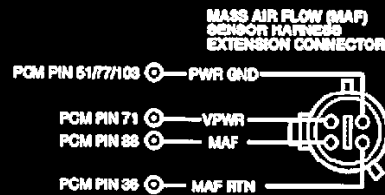

NOTE: ALL HARNESS CONNECTORS ARE VIEWED INTO MATING SURFACE

AA3318-B

Schematics, And Connectors

Tables and Chart

BAROMETRIC PRESSURE REFERENCE CHART			
Barometric Pressure (in. Hg.)	Barometric Pressure (kPa)	BARO/MAF PID (Hz)	Altitude Above Sea Level (ft)
3.5	11	89.3	
20	69	130	10,000
21	71	132	9,000
22	75	136	8,000
23	78	138	7,000
24	82	142	6,000
25	84	144	5,000
26	89	147	4,000
27	93	151	2,000
29	98	155	1,000
30	102	159	0 (sea level)
31.875	105	162	-500

Barometric Pressure Chart

DC: Mass Air Flow (MAF) Sensor**DC1 DTC P1101: CHECK FOR MAF SENSOR CONTINUOUS MEMORY DTCs**

- Drive vehicle for 6 to 10 minutes.
- Rerun KOER, KOEO Self-Test and retrieve Continuous Memory DTCs.

Is a Continuous Memory DTC present with the KOER DTC P1101?

Yes	No
For Continuous Memory DTC P0102: GO to <u>DC2</u> .	KEY OFF. GO to <u>DC3</u> .
For Continuous Memory DTC P0103: GO to <u>DC20</u> .	
All other Continuous Memory DTCs: GO to <u>Diagnostic Trouble Code (DTC) Charts</u> .	

DC2 DTC P0102: CHECK MAF SENSOR SIGNAL LOW INPUT TO PCM

- Check for broken/loose air outlet tube clamps (throttle body and air cleaner assembly ends), cracks/holes in air outlet tube, worn gaskets between MAF sensor and air cleaner assembly. Repair as necessary.
- Verify MAF sensor is connected. If not, repair as necessary.
- Start engine and bring to idle.
- If a KOER DTC P0505 is present, go to Diagnostic Trouble Code (DTC) Charts. For A/T vehicles, if the engine stalls and cannot maintain an idle, GO to DC7 .
- Run engine up 1500 rpm for 5 seconds, then bring it back to idle.
- Access MAF V PID.

Is MAF V PID less than 0.23 volt?

Yes	No
KEY OFF. GO to <u>DC4</u> .	KEY OFF. GO to <u>DC3</u> .

DC3 DTC P1101: CHECK MAF SIGNAL SENT TO PCM

Note: DTC P1101 can be generated by a low charged vehicle battery or the garage exhaust ventilation system. Repair battery as necessary. Then remove ventilation system and properly vent to outside atmosphere. Check air inlet system (air cleaner, housing, ductwork, etc.) for obstructions or blockage. Rerun KOEO Self-Test.

- Verify MAF sensor is connected. If not, repair as necessary.
- Key on, engine off.
- Access MAF V PID using scan tool.

Is voltage less than 0.2 volts?

Yes	No
GO to <u>DC4</u> .	KEY OFF. GO to <u>DC5</u> .

DC4 CHECK FOR MAF SENSOR SIGNAL OUT OF SELF-TEST RANGE

- Key on , engine running.
- Access MAF V PID.

Is MAF V PID between 0.46-2.44 volts?

Yes	No
Unable to identify fault at this time. GO to <u>Z1</u> .	KEY OFF. GO to <u>DC5</u> .

DC5 CHECK VPWR VOLTAGE TO MAF SENSOR

Note: Refer to the PCM connector pin numbers in the beginning of this pinpoint test.

- Disconnect MAF sensor.
- Key on , engine off.
- Measure voltage between VPWR circuit at the MAF sensor harness connector and battery negative post.

Is voltage greater than 10.5 volts?

Yes	No
GO to <u>DC6</u> .	REPAIR open circuit. RESET the keep alive memory (KAM), REFER to <u>Resetting The Keep Alive Memory (KAM)</u> .

DC6 CHECK PWR GND CIRCUIT BETWEEN MAF SENSOR AND POWER RELAY

- Measure voltage between PWR GND circuit at the MAF sensor harness connector and battery positive post.

Is voltage greater than 10.0 volts?

Yes	No
KEY OFF. GO to <u>DC7</u> .	REPAIR open circuit. RESET the keep alive memory (KAM), REFER to <u>Resetting The Keep Alive Memory (KAM)</u> .

DC4 - DC6

DC7 CHECK FOR SHORTS BETWEEN CIRCUITS IN MAF HARNESS

- PCM disconnected.
- Disconnect scan tool from DLC.
- For non-integrated MAF sensor, measure the resistance between the MAF signal circuit harness side and the following MAF sensor circuits, harness side:
 - PWR GND
 - MAF RTN
- For integrated MAF sensor, measure the resistance between the MAF signal circuit harness side and the following MAF sensor circuits, harness side:
 - PWR GND
 - MAF RTN
 - SIG RTN
 - IAT

Are the resistances greater than 10,000 ohms?

Yes	No
GO to DC8 .	REPAIR the circuit in question. RESET the keep alive memory (KAM). REFER to <u>Resetting The Keep Alive Memory (KAM)</u> .

DC8 CHECK MAF RTN CIRCUIT SHORT TO PWR GND IN THE HARNESS

- Measure resistance between MAF RTN and PWR GND circuits at the MAF sensor harness connector.

Is the resistance greater than 10,000 ohms?

Yes	No
RECONNECT scan tool to DLC. GO to <u>DC9</u> .	REPAIR short circuit. RESET the keep alive memory (KAM). REFER to <u>Resetting The Keep Alive Memory (KAM)</u> .

DC9 CHECK MAF CIRCUIT VOLTAGE CYCLING INTEGRITY

- Reconnect PCM.
- Key on , engine off.
- Access MAF V PID.
- Record the MAF V PID reading.
- Jumper MAF RTN and PWR GND circuits at the MAF sensor harness connector.
- Jumper MAF and VPWR circuits at the MAF sensor harness connector.

Does the MAF V PID change from less than 0.23 volt (closer to zero volts) to greater than 4.50 volts?

Yes	No
REPLACE MAF sensor. RESET the keep alive memory (KAM). REFER to <u>Resetting The Keep Alive Memory (KAM)</u> .	For DTC P1101 without P0102 present: KEY OFF. GO to <u>DC11</u> . For DTC P0102: KEY OFF. GO to <u>DC10</u> .

DC10 CHECK MAF CIRCUIT FOR OPEN IN HARNESS

Note: Refer to the PCM connector pin numbers in the beginning of this pinpoint test.

- Disconnect PCM.
- Measure resistance of MAF circuit between PCM harness connector pin and MAF sensor harness connector.

Is resistance less than 5.0 ohms?

Yes	No
GO to DC11 .	REPAIR open circuit. RESET the keep alive memory (KAM). REFER to Resetting The Keep Alive Memory (KAM) .

DC11 CHECK PWR GND CIRCUIT FOR OPEN IN HARNESS

- PCM disconnected.
- Disconnect scan tool from DLC.
- Measure resistance of PWR GND circuit between MAF sensor harness connector and battery negative post.

Is resistance less than 10 ohms?

Yes	No
RECONNECT scan tool. GO to DC12 .	REPAIR open circuit. RESET the keep alive memory (KAM). REFER to Resetting The Keep Alive Memory (KAM) .

DC12 CHECK MAF RTN FOR OPEN IN HARNESS

Note: Refer to the PCM connector pin numbers in the beginning of this pinpoint test.

- Measure resistance of MAF RTN circuit between PCM harness connector pin and MAF sensor harness connector.

Is resistance less than 5.0 ohms?

Yes	No
REPLACE PCM (refer to Flash Electrically Erasable Programmable Read Only Memory (EEPROM)).	REPAIR open circuit. RESET the keep alive memory (KAM). REFER to Resetting The Keep Alive Memory (KAM) .

DC16 DTC P1100: CHECK MAF CIRCUIT FOR INTERMITTENT VOLTAGE TO PCM

- Start engine and bring it to idle.
- If a stable idle is not at least 700 rpm, GO to Symptom Charts.
- Run throttle up to 1500 rpm for 5 seconds, and bring back to idle.
- Access MAF V PID.
- Lightly tap on MAF sensor and wiggle harness connector to simulate road shock.

Is MAF V PID changing below the minimum 0.23 volt or above a maximum 4.60 volts?

Yes	No
INSPECT MAF sensor connector. If OK, REPLACE the MAF sensor. RESET the keep alive memory (KAM). REFER to <u>Resetting The Keep Alive Memory (KAM)</u> .	GO to <u>DC17</u> .

DC17 CHECK FOR MAF SENSOR CIRCUIT FOR INTERMITTENT OPENS OR SHORTS

- Again access the MAF V PID.
- Key on, engine off.
- Complete the following:
 - Grasp the MAF sensor harness and MAF sensor harness connector.
 - Shake and bend a small section of the harness all the way to the dash panel.
 - Wiggle, shake and bend the harness from the dash panel to the PCM.

Is the MAF V PID reading changing below the minimum 0.23 volt or above the maximum 4.60 volts?

Yes	No
REPAIR as necessary. RESET the keep alive memory (KAM). REFER to <u>Resetting The Keep Alive Memory (KAM)</u> .	Unable to duplicate or identify fault at this time. GO to <u>Z1</u> .

DC16 - DC17

DC20 DTC P0103: CHECK MAF SENSOR SIGNAL HIGH INPUT TO PCM

Note: DTC P0103 can be generated by foreign material blocking the MAF sensor screen causing an air flow restriction. If contaminants are found on the screen, check air cleaner element installation in air cleaner housing and proper sealing of air cleaner and air tubes before proceeding. Rerun Quick Test after service.

- Start engine and bring to idle.
- If a KOER DTC P0505 is present, GO to [Diagnostic Trouble Code \(DTC\) Charts](#).
- Run throttle up to 1500 rpm for 5 seconds, and bring it back to idle.

Note: MAF V PID is greater than 4.60 volts.

- Access MAF V PID.
- Key off.
- Disconnect MAF sensor.
- Jumper PWR GND and MAF RTN circuits at the MAF sensor harness connector.
- Key on, engine running.
- Again access MAF V PID.

Did MAF V PID drop from the previous reading to below 0.23 volt?

Yes	No
REMOVE jumper. REPLACE MAF sensor. RESET the keep alive memory (KAM). REFER to Resetting The Keep Alive Memory (KAM) .	KEY OFF. REMOVE jumper. GO to DC21 .

DC21 CHECK MAF CIRCUIT FOR SHORT TO VPWR IN HARNESS

Note: Refer to the PCM connector pin numbers in the beginning of this pinpoint test.

- Disconnect PCM.
- Key on, engine off.
- Measure voltage between MAF and PWR GND circuits at the PCM harness connector.

Is voltage less than 1.0 volt?

Yes	No
<p>If an idle concern is not present:</p> <p>REPLACE PCM (refer to Flash Electrically Erasable Programmable Read Only Memory (EEPROM)).</p> <p>If a fault was not detected and an idle concern is still present:</p> <p>Disregard DTC P0102 at this time. RETURN to Symptom Charts.</p>	REPAIR short circuit.

DC25 DTC P0171, P0172, P0174, P0175, P1131, P1132, P1151, P1152, P1130, P1150 OR LEAN DRIVEABILITY CONCERNS: CHECK CONDITIONS RELATED TO MAF SENSOR

Note: Most weather service reports are a local barometric pressure that has been corrected to sea level. However, the BARO PID reports the actual barometric pressure for the altitude the vehicle is being diagnosed in. Local weather conditions (high or low pressure areas) will change the local barometric pressure by several inches of mercury (+/- 3 Hz. (+/- 1 in.Hg.)).

Note: The BARO PID values in Keep Alive Memory require updating at high throttle openings. If vehicle is driven down from higher altitudes for diagnosing, complete three or four heavy accelerations at greater than half-throttle to allow BARO PID to update. Make BARO PID comparisons to Barometric Pressure Reference Chart or hourly airport barometric pressure or altimeter reports, if available. The BARO PID must be within +/- 6 Hz (+/- 2 in.Hg.) of the altitude value in Barometric Pressure Reference Chart (at the beginning of this pinpoint test).

Note: A MAF V PID value of less than 0.6 volt may indicate a misassembled air cleaner or a leak in the air inlet system.

- Verify the MAF sensor is connected. If not, repair as necessary.
- Key on, engine running.
- Access the BARO, LONGFT1, LONGFT2 and MAF V PIDs on fully warmed-up engine.
- Carry out the following diagnostic checks:
 - Check that the BARO PID is approximately the same as the barometric pressure reading for the location, day and altitude the vehicle is being diagnosed at.
 - Check that the MAF V PID at idle and neutral is not greater than 30% of the normal MAF V listed in Reference Values (or not greater than 1.3 volts).

Are the PID values within the expected ranges?

Yes	No
For DTC P0171, P0172, P0174, P0175, P1131, P1132, P1151, P1152, P1130 or P1150 : Unable to duplicate or identify the fault at this time, GO to <u>Z1</u> (or GO to <u>HA42</u> for natural gas vehicles only). For driveability symptoms without DTCs : RETURN to Symptom Charts for further diagnosis.	KEY OFF. GO to <u>DC26</u> .

DC25

DC26 CHECK TO ISOLATE MAF SENSOR FROM LEAN DRIVEABILITY OCCURRENCE

Note: Due to increasingly stringent emission/OBD II requirements, a fuel system DTC on some vehicles will be generated without a noticeable driveability concern with or without the MAF sensor disconnected. Under these conditions, if the BARO, LONGFT1, LONGFT2 and MAF V PID indicates a MAF sensor concern, replace the MAF sensor.

- Disconnect the MAF sensor.
- Key on, engine running.
- Drive the vehicle.

Is the lean driveability symptom (lack of power, spark knock/detonation, buck/jerk or hesitation/surge on acceleration) gone?

Yes	No
REPLACE MAF sensor. RESET the keep alive memory (KAM). REFER to <u>Resetting The Keep Alive Memory (KAM)</u> . VERIFY a symptom no longer exists.	For DTC P0171, P0172, P0174, P0175, P1131, P1132, P1151, P1152, P1130 or P1150 : Unable to duplicate or identify the fault at this time, GO to <u>Z1</u> (or GO to <u>HA42</u> for natural gas vehicles only). For lean driveability symptoms listed without DTCs : RETURN to Symptom Charts for further diagnosis.

DC26