

Intake Manifold: Service and Repair Removal and Installation

Intake Manifold

Material	
Item	Specification
Metal Surface Prep ZC-31	—
Silicone Gasket Remover ZC-30	—

Material

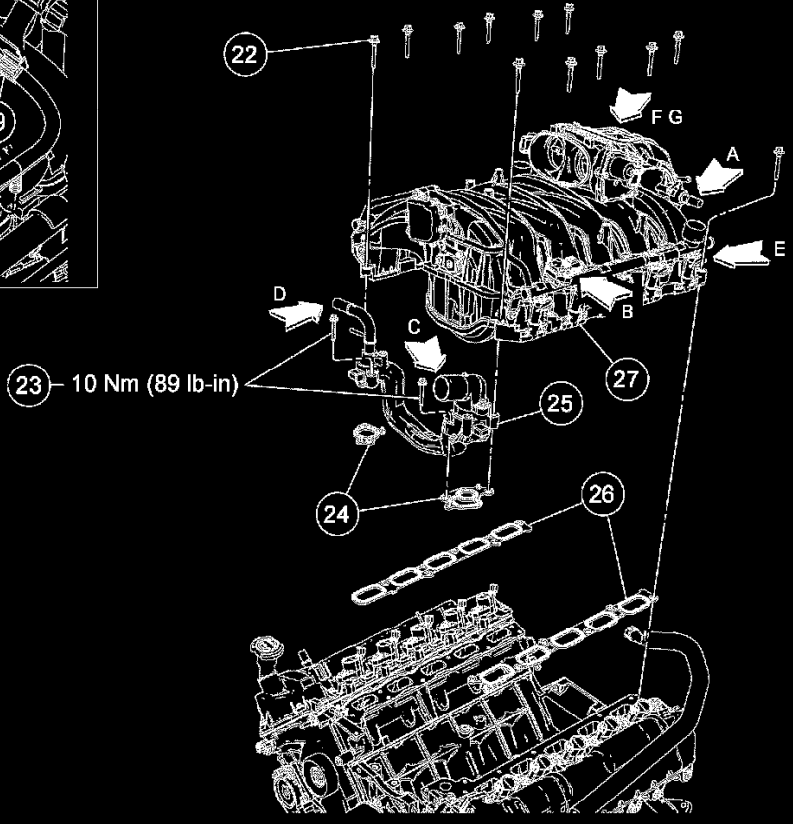
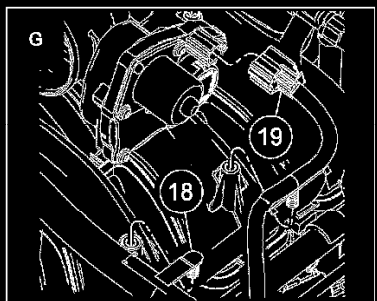
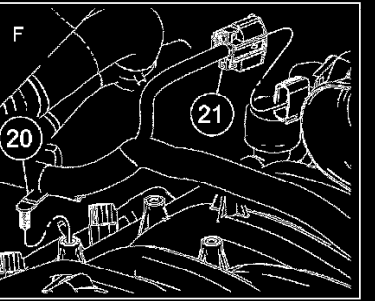
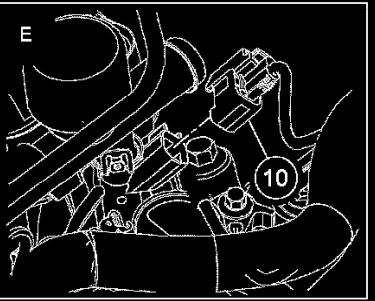
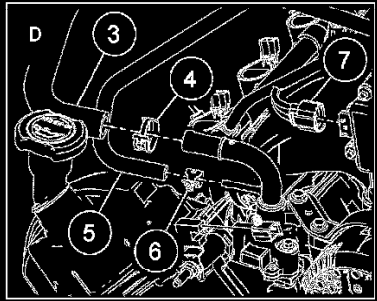
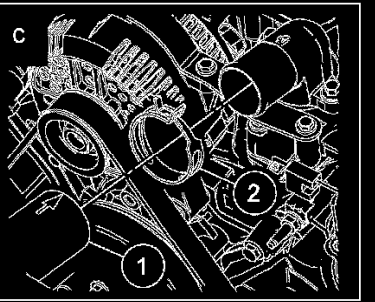
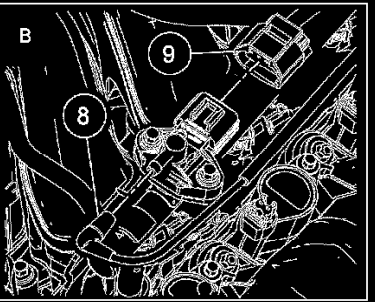
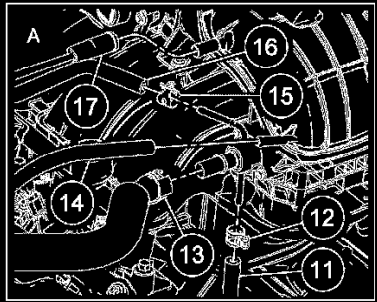

Item	Description
1	Radiator hose
2	Radiator hose clamp
3	Heater hose
4	Heater hose clamp
5	Positive crankcase ventilation (PCV) coolant hose
6	PCV coolant hose clamp
7	Intake manifold runner control (IMRC) actuator electrical connector
8	Fuel rail pressure and temperature sensor vacuum hose
9	Fuel rail pressure and temperature sensor electrical connector
10	Fuel injector electrical connector (10 required)
11	PCV coolant hose
12	PCV coolant hose clamp
13	PCV tube
14	Brake booster vacuum hose
15	PCV coolant hose clamp
16	PCV coolant hose
17	Intake manifold vacuum hose
18	Engine wiring harness retainer
19	Electronic throttle control electrical connector
20	Engine wiring harness retainer
21	Throttle position (TP) sensor electrical connector
22	Intake manifold bolt (12 required)
23	Engine coolant crossover assembly bolts (2 required)
24	Engine coolant crossover assembly gaskets (2 required)
25	Engine coolant crossover assembly
26	Intake manifold gaskets (2 required)
27	Intake manifold assembly

Removal

WARNING: Do not smoke or carry lighted tobacco or open flame of any type when working on or near any fuel-related component. Highly flammable mixtures are always present and may be ignited. Failure to follow these instructions may result in personal injury.

WARNING: Fuel in the fuel system remains under high pressure even when the engine is not running. Before servicing or disconnecting any of the fuel lines or fuel system components, the fuel system pressure must be relieved to prevent accidental spraying of fuel, causing personal injury or a fire hazard.

1. Disconnect the fuel supply spring lock coupling from the fuel rail. For additional information, refer to Fuel Delivery and Air Induction.

2. Drain the cooling system. For additional information, refer to Cooling System.
3. Remove the generator. For additional information, refer to Alternator.
4. Remove the air cleaner outlet pipe. For additional information, refer to Fuel Delivery and Air Induction.
5. Disconnect the upper radiator hose from the thermostat housing.
6. Disconnect the heater coolant hose from the coolant crossover assembly.
7. Disconnect the intake manifold runner control (IMRC) actuator electrical connector.
8. Disconnect the fuel rail pressure and temperature sensor electrical connector and vacuum connector.
9. Disconnect the 10 fuel injector electrical connectors.
10. Disconnect the positive crankcase ventilation (PCV) tube quick connect coupling from the intake manifold. For additional information, refer to Fuel Delivery and Air Induction.



11. Disconnect the quick connect couplings and remove the evaporative emissions (EVAP) tube. For additional information, refer to Fuel Delivery and Air Induction.
12. Disconnect the brake booster and engine vacuum hose connections from the rear of the intake manifold and position aside.
13. Disconnect the 2 heated PCV coolant hoses from the intake manifold.
14. Disconnect the throttle position (TP) sensor and electronic throttle control electrical connectors.
15. Disconnect the engine wiring harness position retainers from the intake manifold.
16. Remove the 12 intake manifold bolts.
17. **CAUTION:** Do not use metal scrapers, wire brushes, power abrasive discs or other abrasive means to clean the sealing surfaces. These tools cause scratches and gouges which make leak paths. Use a plastic scraping tool to remove all traces of old sealant.

Remove the 2 bolts, the coolant crossover tube and discard the gaskets.

^ Clean and inspect the sealing surfaces with silicone gasket remover and metal surface prep. Follow the directions on the packaging.

18. **CAUTION:** Do not use metal scrapers, wire brushes, power abrasive discs or other abrasive means to clean the sealing surfaces. These tools cause scratches and gouges which make leak paths. Use a plastic scraping tool to remove all traces of old sealant.

Remove the intake manifold and discard the gaskets.

^ Clean and inspect the sealing surfaces with silicone gasket remover and metal surface prep. Follow the directions on the packaging.

Installation

1. Using new intake manifold gaskets, position the intake manifold.
2. Using new gaskets, position the coolant crossover tube and install the 2 bolts
- ^ Tighten to **10 Nm (89 inch lbs.)**.

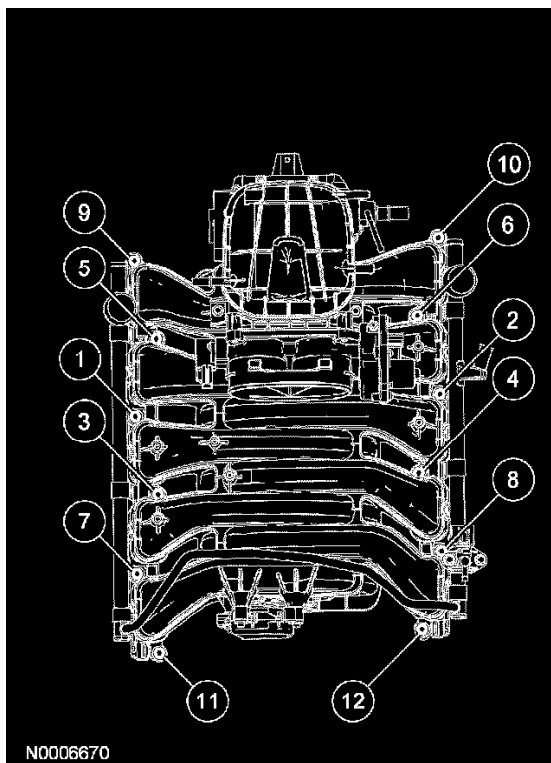

N0006670

3. Install the intake manifold bolts and tighten in 2 stages in the sequence shown.
 - ^ Stage 1: Tighten to **2 Nm (18 inch lbs.)**.
 - ^ Stage 2: Tighten to **10 Nm (89 inch lbs.)**.
4. Connect the TP sensor and electronic throttle control electrical connectors.
5. Connect the engine wiring harness position retainers to the intake manifold.
6. Connect the brake booster and engine vacuum hose connections to the rear of the intake manifold.
7. Connect the PCV tube quick connect coupling to the intake manifold. For additional information, refer to Fuel Delivery and Air Induction.



N0011698

8. Position the EVAP tube and connect the quick connect couplings. For additional information, refer to Fuel Delivery and Air Induction.
9. Connect the 2 heated PCV coolant hoses to the intake manifold.
10. Connect the 10 fuel injector electrical connectors.
11. Connect the fuel rail pressure and temperature sensor electrical connector and vacuum connector.
12. Connect the IMRC actuator electrical connector.
13. Connect the fuel supply spring lock coupling to the fuel rail. For additional information, refer to Fuel Delivery and Air Induction.
14. Connect the heater coolant hose to the coolant crossover assembly.
15. Connect the heated PCV coolant hose to the coolant crossover assembly.
16. Connect the upper radiator hose to the thermostat housing.
17. Install the generator. For additional information, refer to Alternator.
18. Install the air cleaner outlet pipe. For additional information, refer to Fuel Delivery and Air Induction.
19. Fill and bleed the engine cooling system. For additional information, refer to Cooling System.