

Instrument Cluster / Carrier: Service and Repair

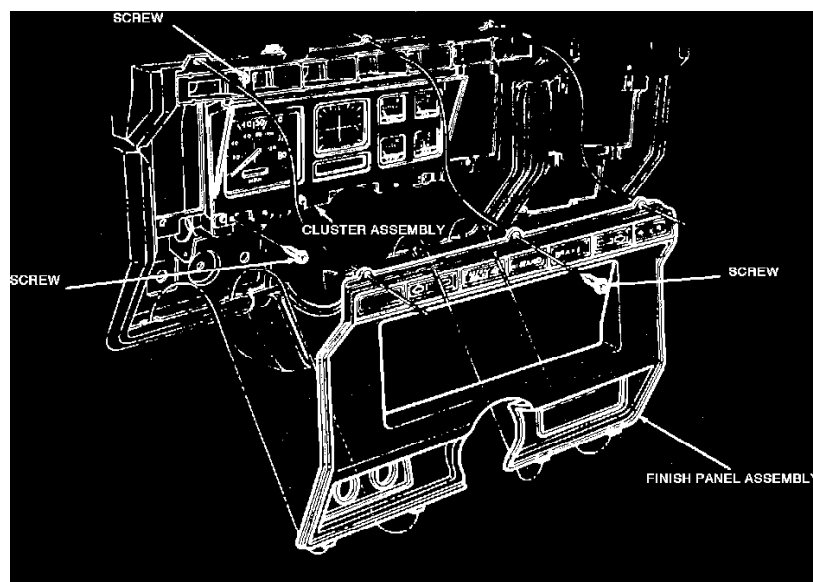

Fig. 10 Instrument Cluster

1. Disconnect battery ground cable.
2. Remove wiper/washer knob. Use a suitable hook tool to release knob lock tab.
3. Remove light switch knob, windshield wiper switch knob and fog light switch knob, if equipped.
4. Remove steering column shroud, using care not to damage transmission selector indicator cables on models equipped with automatic transmission.
5. **On models equipped with automatic transmission**, release shift lever indicator cable retaining clip(s), then remove cable loop from retainer pin. Remove cable bracket attaching screw and slide bracket out of slot in tube.
6. **On all models**, remove cluster finish panel and the cluster attaching screws, **Fig. 10**.
7. Pull cluster back from panel and disconnect speedometer cable, printed circuit electrical connector and 4 X 4 indicator light electrical connector, if equipped.
8. Remove cluster from vehicle, **Fig. 10**.
9. Reverse procedure to install.