

Dashboard / Instrument Panel: Service and Repair

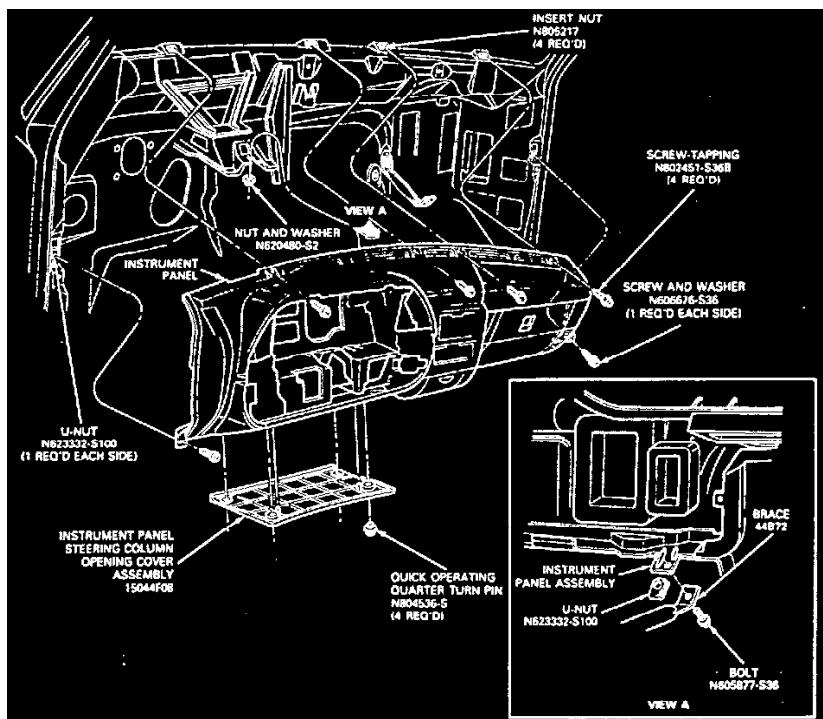

Fig. 4 Exploded View Of Instrument Panel, 1988-91 Bronco & F-Series.

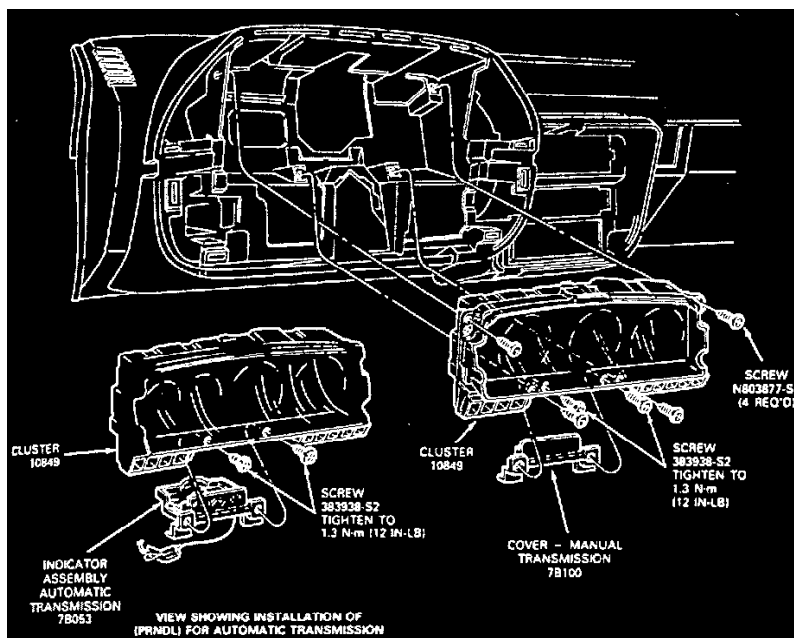

Fig. 5 Exploded View Of Instrument Cluster, 1988-91 Bronco & F-series.

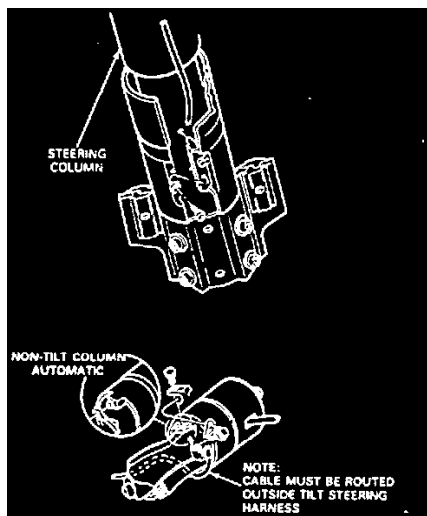

Fig. 6 Transmission Selector Cable R&R. 1988-91 Bronco & F-series.

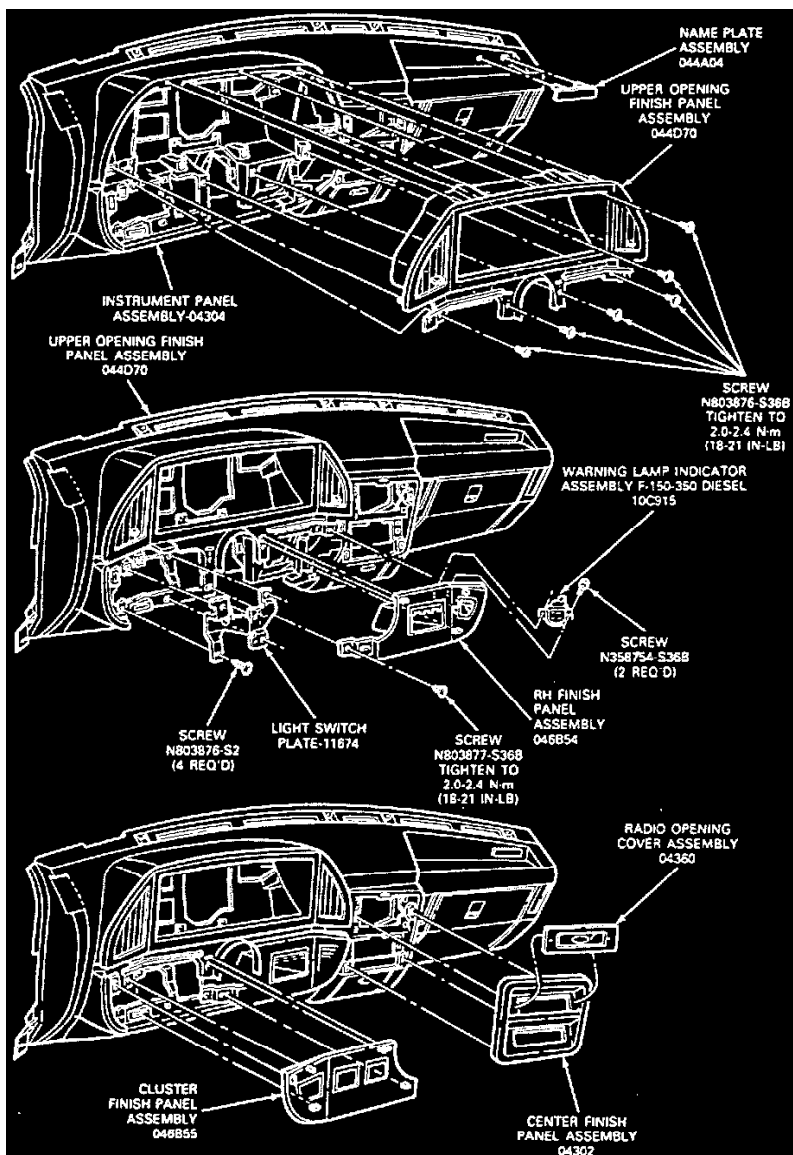

Fig. 7 Exploded View Of Cluster Opening & Finish Panels. 1988-91 Bronco & F-series.

1. Disconnect negative battery cable.
2. Remove nut and washer assembly attaching the instrument panel to the brake and clutch pedal support.
3. Remove instrument panel to instrument panel brace bolt, **Fig. 4**.
4. Remove steering column opening cover, then disconnect transmission selector indicator cable, if equipped, **Figs. 5 and 6**. The cover fasteners are

quick operating pins and require a quarter of a turn.

5. Remove instrument panel lower corner to cowl side attaching screws and washers.
6. Disconnect blower switch and lever assembly, A/C control switch and push button assembly and the control assembly bulb, **Fig. 7**.
7. Disconnect vacuum lines and control cables from control panel.
8. Remove screws securing instrument panel to dash panel, **Fig. 4**.
9. Lift instrument panel assembly up and over steering column and wheel.
10. Reverse procedure to install. If any of the instrument panel to dash panel insert nuts are damaged, they should be replaced using part No. N805217.