

Dashboard / Instrument Panel: Service and Repair

Installation

INSTRUMENT PANEL

INSTALLATION

All vehicles

1. **NOTE:** This step requires an assistant.

Install the instrument panel.

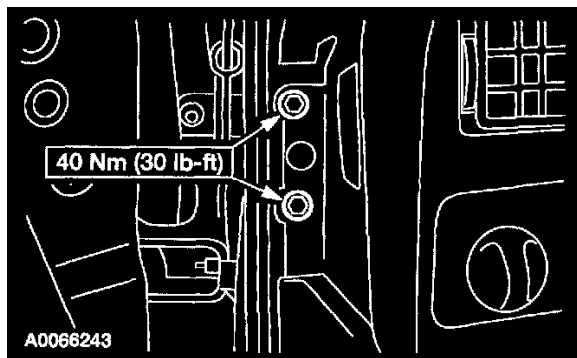

2. Install the LH instrument panel cowl side bolts.

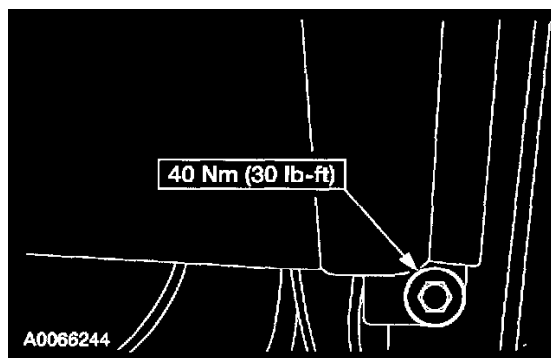

3. Install the lower RH instrument panel cowl side bolt.

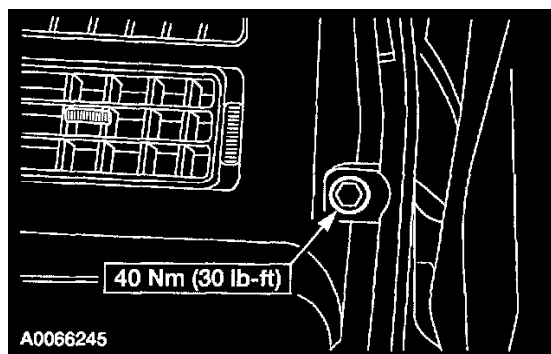

4. Install the upper RH instrument panel cowl side bolt.

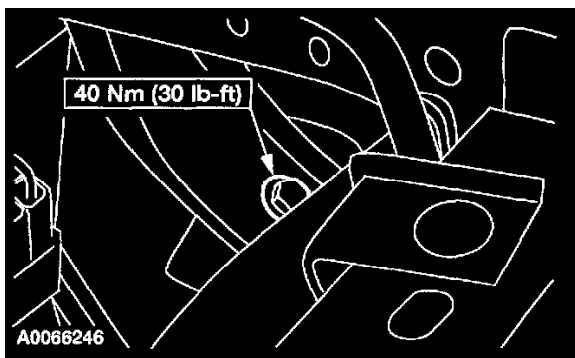

5. Install the LH instrument panel center support bolt.

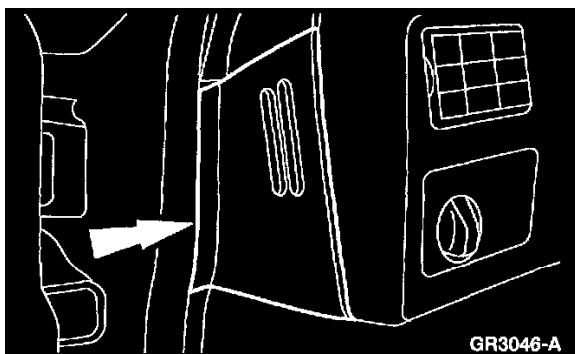

6. Install the LH instrument panel end finish panel.

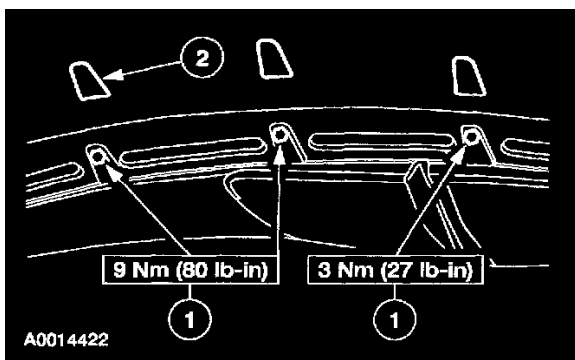

7. install the instrument panel cowl top bolts.
 - 1 Install the bolts.
 - 2 Install the cowl top attaching bolt covers.

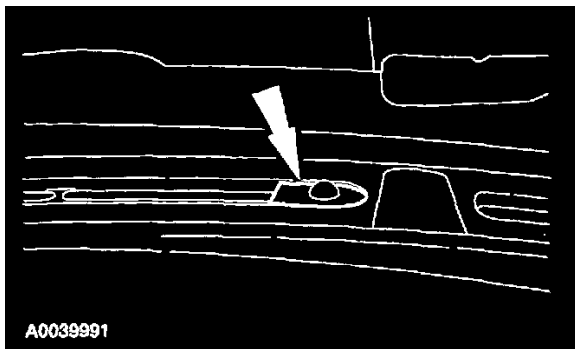

8. Install the autolamp sunload sensor finish panel.
 - Connect the electrical connector.

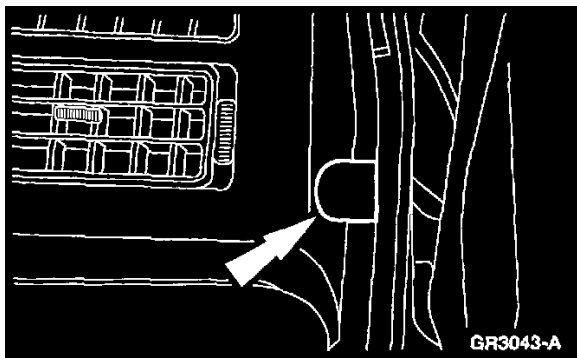

9. Install the RH cowl side bolt cover.

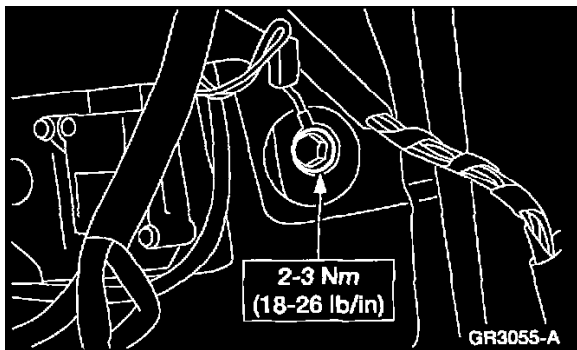

10. Install the RH ground bolt.

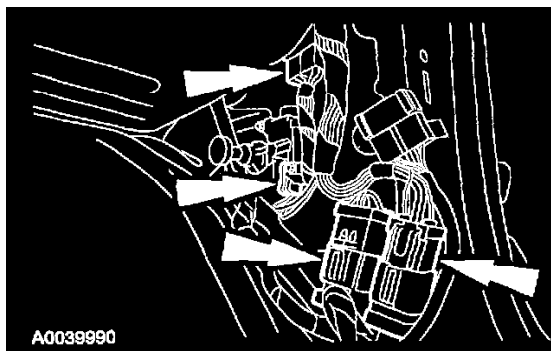

11. Connect the RH cowl side electrical connectors.

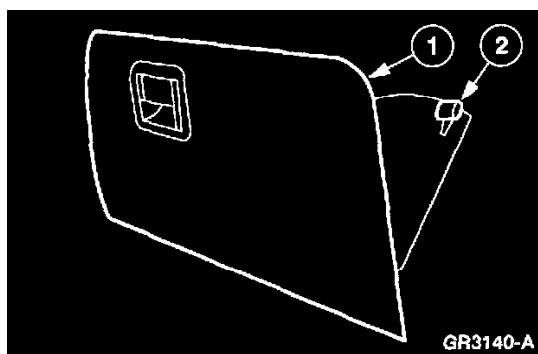

12. Lower the glove compartment.

- 1 Open the glove compartment.
- 2 While releasing the glove compartment stops, lower the glove compartment.

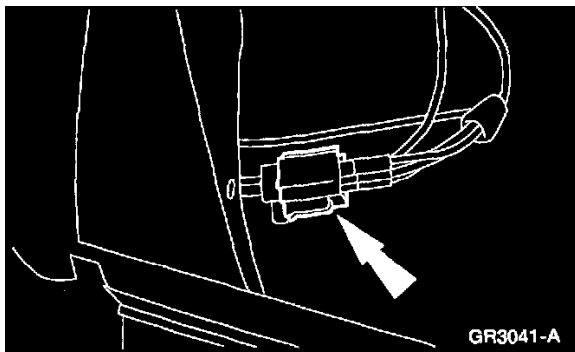

13. Connect the climate control vacuum harness connector.

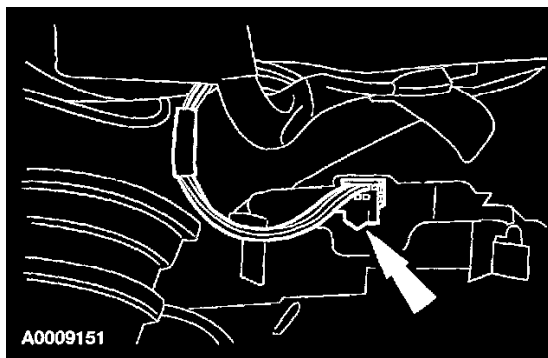

14. Connect the blend door actuator electrical connector.

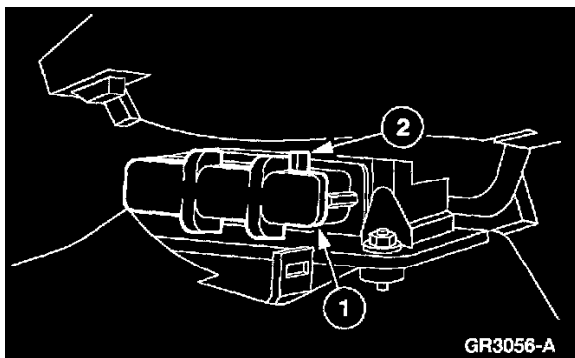

15. Connect the ECS module electrical connector.
1 Connect the ECS module electrical connector.
2 Install the locking clip.

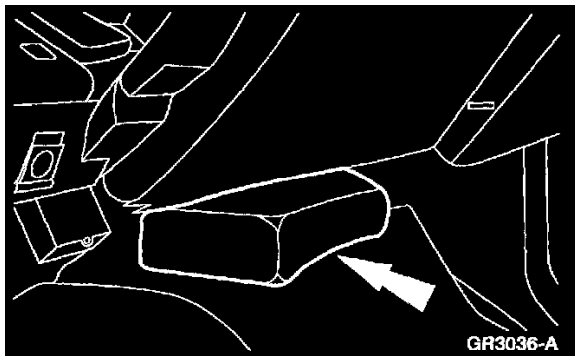

16. Install the ECS module cover.

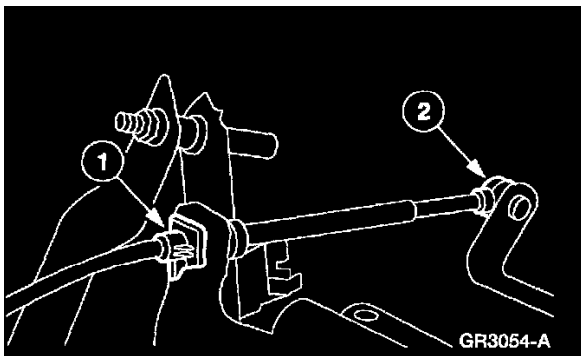

17. If equipped, connect the transmission shift cable to the steering column.

- 1 Connect the cable to the steering column bracket.
- 2 Connect the cable to the steering column shift lever.

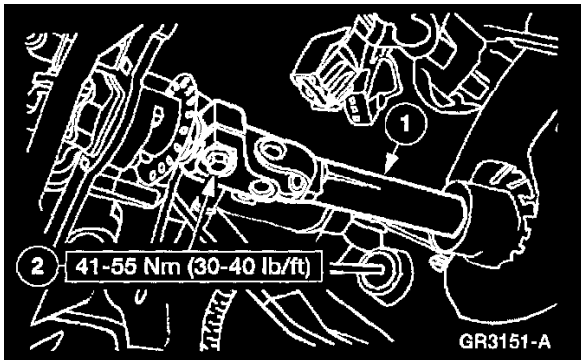

18. Connect the intermediate shaft to the steering column.

- 1 Connect the intermediate shaft to the steering column.
- 2 Install the steering column shaft pinch bolt.

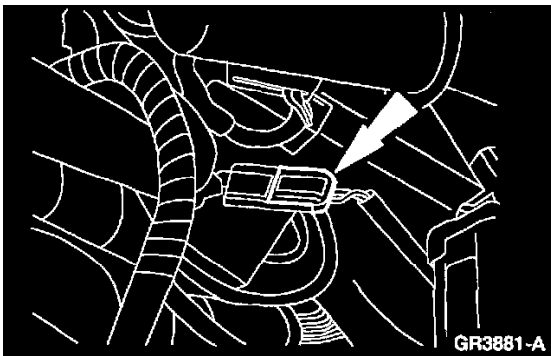

19. If equipped, connect the adjustable pedal motor harness electrical connector.

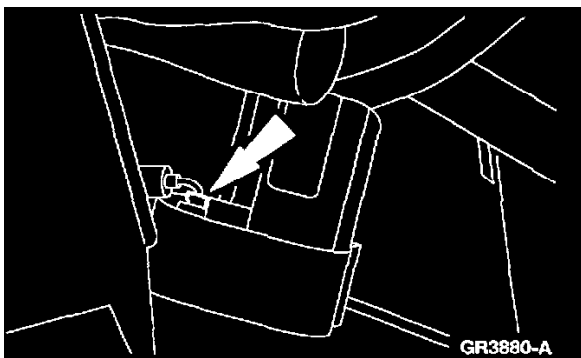

20. If equipped, connect the adjustable pedal motor electrical connector.

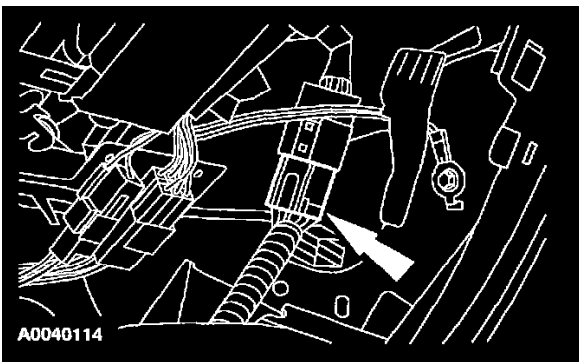

21. Through the steering column opening, connect the wiring harness electrical connector.

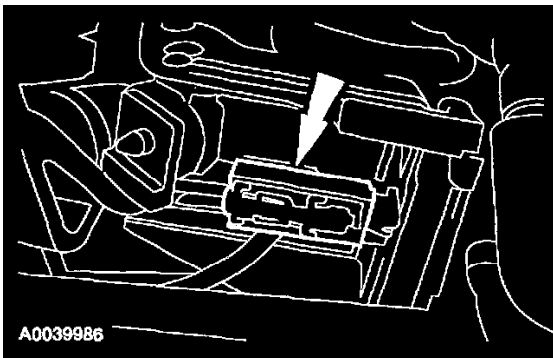

22. If equipped, connect the CPP switch electrical connector.

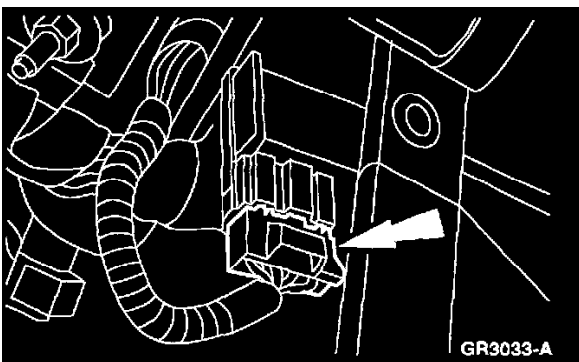

23. Connect the BPP switch electrical connector.

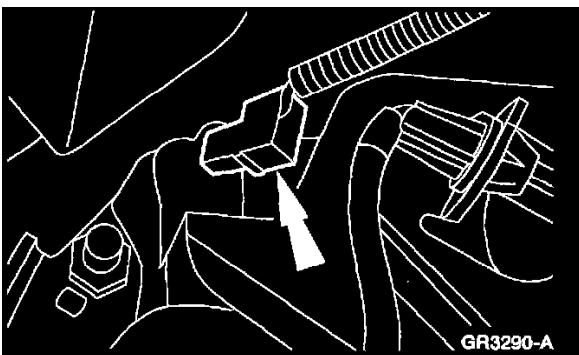

24. Connect the parking brake switch electrical connector.

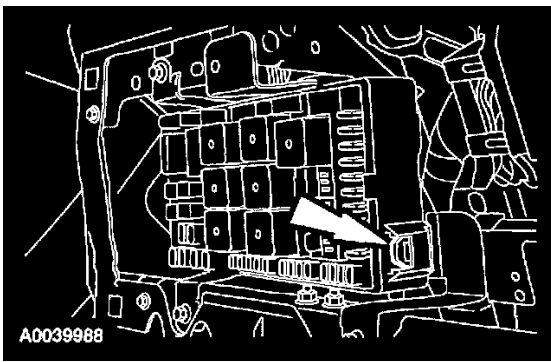

25. Position the CJB aside.
- Release the tab.

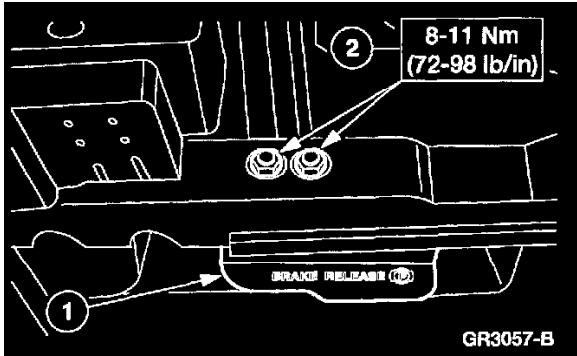

26. Install the parking brake release handle.
1 Position the parking brake release handle.
2 Install the nuts.

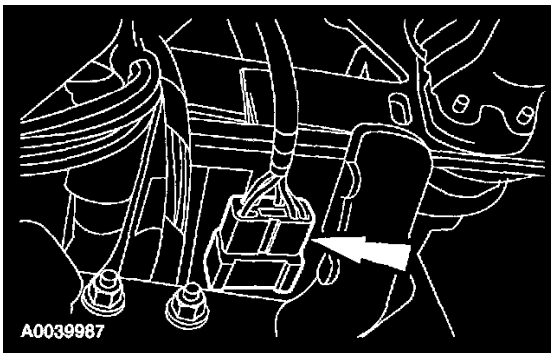

27. Connect the in-line electrical connector.

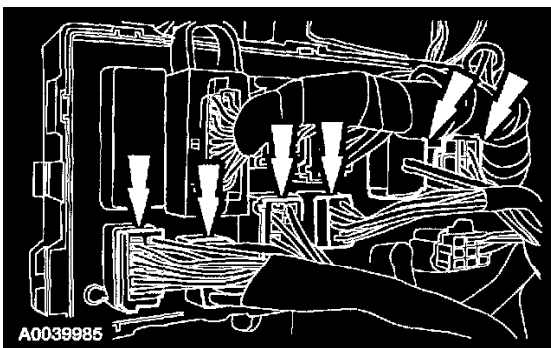

28. Connect the CJB electrical connectors.

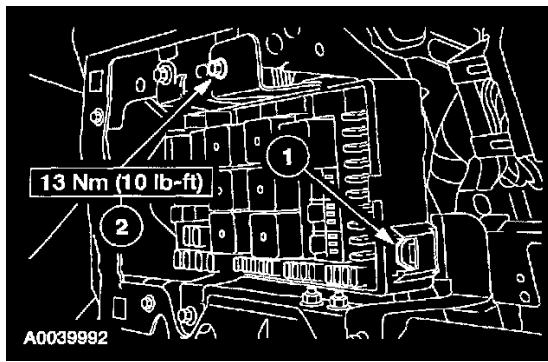

29. Install the CJB.
- 1 Connect the tab.
 - 2 Install the bolt.

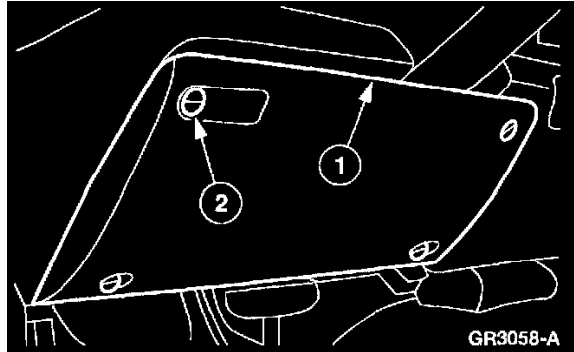

30. Install the instrument panel steering column cover.
- 1 Position the instrument panel steering column cover.
 - 2 Lock the retainers.

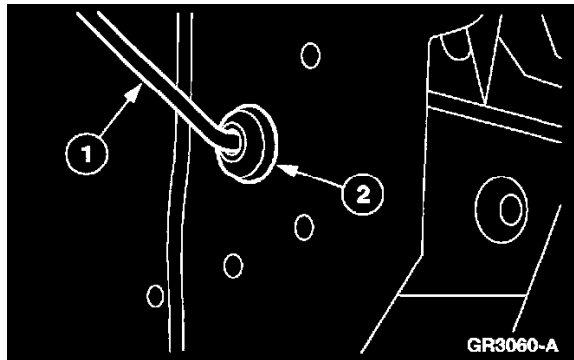

31. Route the antenna cable into the inner fender opening.
- 1 Route the antenna cable into the inner fender opening.
 - 2 Seat the antenna cable grommet into the dash panel.

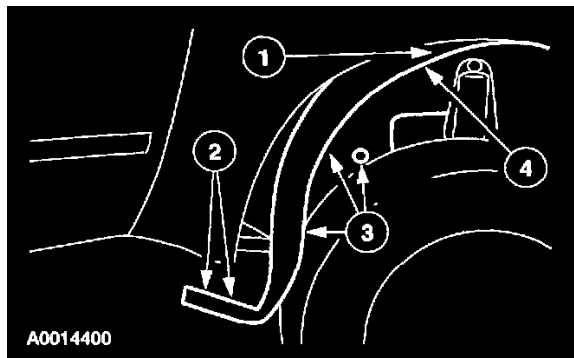

32. Install the RH front fender splash shield.
- 1 Position the front fender splash shield.

- 2 Install the pin-type retainers.
- 3 Install the screws.
- 4 Install the three nuts.

33. Install the antenna base.

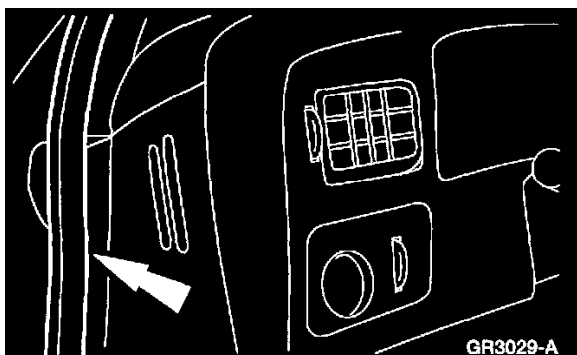

34. Install the LH and RH front door weatherstrips.

Excursion only

35. Position the carpet.

- Engage the floor console wiring harness locator and relocate the harness under the carpet and heat duct.

All vehicles

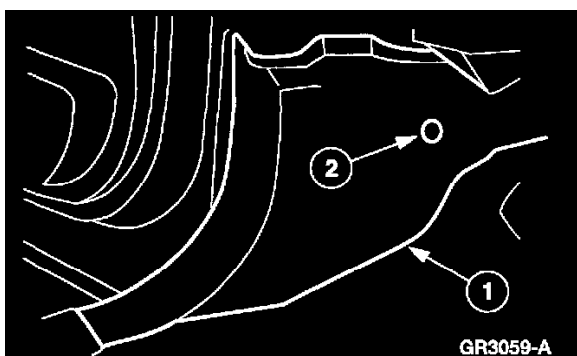

36. Install the LH and RH A-pillar lower trim panels.

- 1 Position the A-pillar lower trim panels.
- 2 Install the pin-type retainers.

37. Install the LH and RH scuff plates.

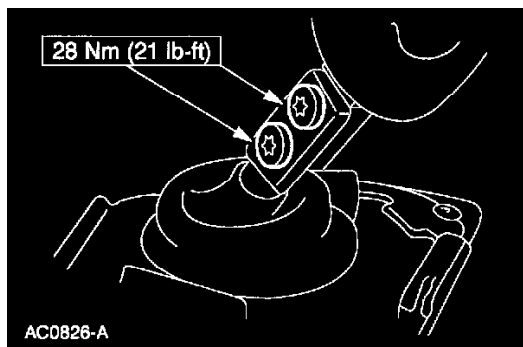

38. If equipped with a manual transmission, install the upper gearshift lever.

- Install the bolts.

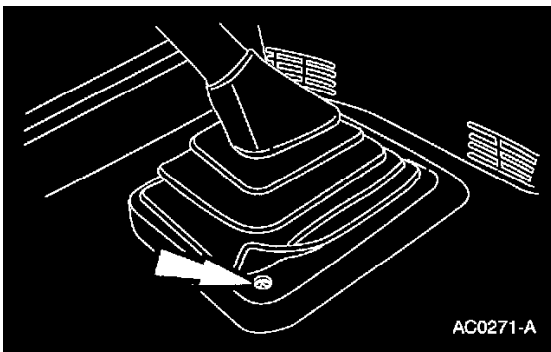

39. If equipped with manual transmission, install the shift lever boot.
- Install the screws.



40. Feed the wiring harness into the engine compartment and connect the electrical connectors.

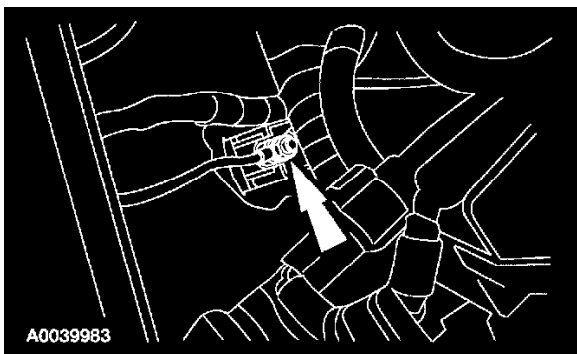

41. Connect the CJB cable at the junction block.
- Feed the cable into the engine compartment and install the wiring harness grommet.
 - Install the nut.



42. Clip the instrument panel harness locator into the pedal bracket.

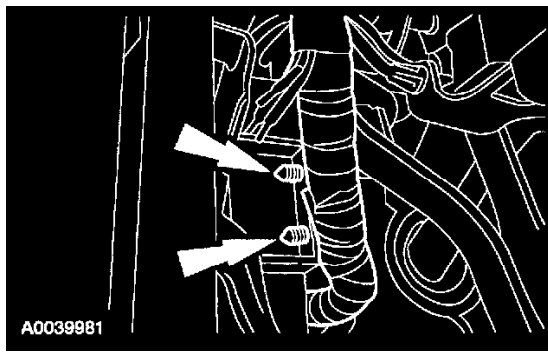

43. Clip the harness locator to the PCM bracket.

Excursion Only

44. Install the floor console.

All vehicles

45. If equipped, install the passenger air bag module.
46. Install the driver air bag module.