

## Cooling System: Testing and Inspection Pinpoint Tests

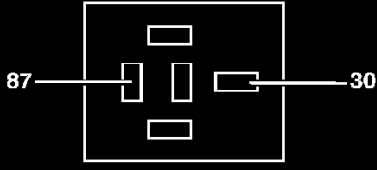

87 ————— 30

A0076751

Pin Number(s)	Circuit Designation/Description	Normal Condition/Measurement
30	CKT 461 (OG) cooling fan relay to fan motor	Greater than 10 volts when cooling fan command on.
87	CKT 3828 (OG/BK) cooling fan motor ground	0 ohms to chassis ground when cooling fan is commanded high.

**Cooling Fan Relay 3**

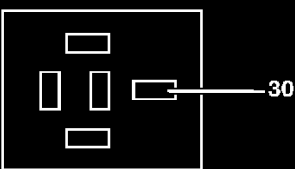

30

A0076752

Pin Number(s)	Circuit Designation/Description	Normal Condition/Measurement
30	CKT 462 (VT) cooling fan motor ground	Greater than 10 volts when cooling fan command on medium or high.

**Cooling Fan Relay 4**

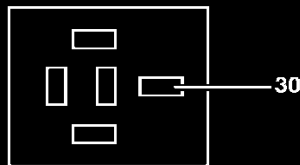

A0076752

Pin Number(s)	Circuit Designation/Description	Normal Condition/Measurement
30	CKT 3828 (OG/BK) cooling fan ground to fan motor	Greater than 10 volts when cooling fan command on.

### Cooling Fan Relay 5

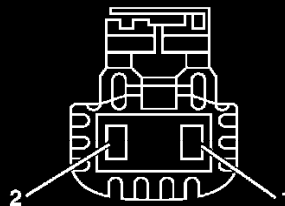

A0052186

### LH Cooling Fan Motor

Pin Number(s)	Circuit Designation/Description	Normal Condition/Measurement
1	CKT 1824 (LG/VT) cooling fan relay to fan motor	Greater than 10 volts when cooling fan relay engaged.
2	CKT 462 (VT) cooling fan motor ground	0 ohms to chassis ground when cooling fan is commanded high.

### LH Cooling Fan Motor

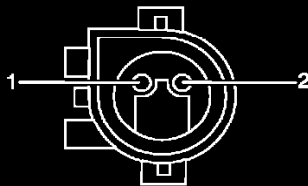

A0052176

Pin Number(s)	Circuit Designation/Description	Normal Condition/Measurement
1	CKT 471 (OG/LG) cooling fan relay to fan resistor	Greater than 10 volts when cooling fans commanded low or medium.
2	CKT 1205 (BK) cooling fan resistor ground	0 ohms to chassis ground.

### Cooling Fan Resistor

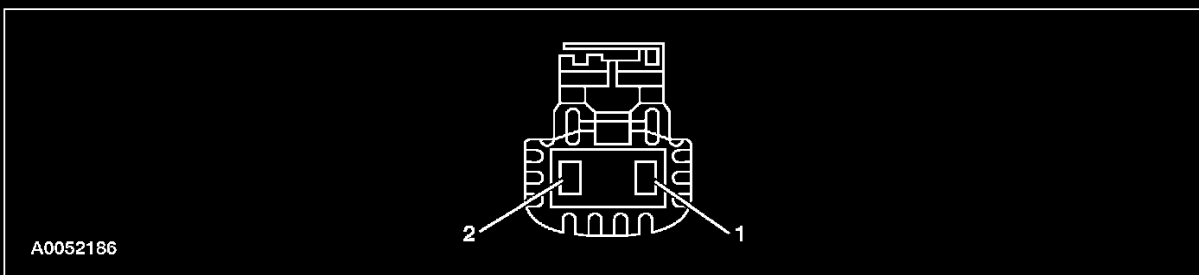

Pin Number(s)	Circuit Designation/Description	Normal Condition/Measurement
1	CKT 1825 (LG/YE) cooling fan relay to fan motor	Greater than 10 volts when cooling fan command on.
2	CKT 461 (OG) cooling fan motor ground	0 ohms to chassis ground when cooling fan is commanded high.

### RH Cooling Fan Motor

## Test A

### PINPOINT TEST A: LOSS OF COOLANT

Test Step		Result / Action to Take
<b>A1</b>	<b>CHECK THE ENGINE COOLANT LEVEL</b>	<p><b>Yes</b> GO to A2.</p> <p><b>No</b> REFILL the engine coolant as necessary. GO to A2.</p>
<p><b>⚠ WARNING:</b> Never remove the pressure relief cap while the engine is operating or when the cooling system is hot. Failure to follow these instructions can result in damage to the cooling system or engine or personal injury. To avoid having scalding hot coolant or steam blow out of the degas bottle when removing the pressure relief cap, wait until the engine has cooled, then wrap a thick cloth around the pressure relief cap and turn it slowly. Step back while the pressure is released from the cooling system. When you are sure all the pressure has been released, turn and remove the pressure relief cap (still with a cloth).</p> <p><b>NOTE:</b> Allow the engine to cool before checking the engine coolant level.</p> <ul style="list-style-type: none"> <li>• Key in OFF position.</li> <li>• Visually check the engine coolant level at the degas bottle.</li> <li>• Is the engine coolant level within specification?</li> </ul>		
<b>A2</b>	<b>CHECK THE DEGAS BOTTLE PRESSURE RELIEF CAP</b>	<p><b>Yes</b> GO to A3.</p> <p><b>No</b> INSTALL a new pressure relief cap. TEST the system for normal operation.</p>
<p><b>⚠ WARNING:</b> To avoid personal injury, do not unscrew the coolant pressure relief cap while the engine is operating or hot. The cooling system is under pressure; steam and hot liquid can come out forcefully when the cap is loosened slightly.</p> <ul style="list-style-type: none"> <li>• Inspect the pressure relief cap for foreign material between the sealing gasket and the diaphragm.</li> <li>• Is pressure relief cap OK?</li> </ul>		

### Steps A1 - A2

Test Step		Result / Action to Take
<b>A3</b>	<b>CHECK THE ENGINE COOLANT FOR INTERNAL LEAK</b>	
	<p> <b>WARNING:</b> Never remove the pressure relief cap while the engine is operating or when the cooling system is hot. Failure to follow these instructions can result in damage to the cooling system or engine or personal injury. To avoid having scalding hot coolant or steam blow out of the degas bottle when removing the pressure relief cap, wait until the engine has cooled, then wrap a thick cloth around the pressure relief cap and turn it slowly. Step back while the pressure is released from the cooling system. When you are sure all the pressure has been released, turn and remove the pressure relief cap (still with a cloth).</p> <ul style="list-style-type: none"> <li>Inspect the engine coolant in degas bottle for signs of transmission fluid or engine oil.</li> <li>Is oil or transmission fluid evident in coolant?</li> </ul>	<p><b>Yes</b> If engine oil is evident, GO to Engine If transmission fluid is evident, INSTALL a new radiator as necessary.</p> <p><b>No</b> GO to A4.</p>
<b>A4</b>	<b>CHECK THE ENGINE AND THE TRANSMISSION FOR COOLANT</b>	
	<ul style="list-style-type: none"> <li>Remove the oil level dipsticks from the engine and the transmission.</li> <li>Is coolant evident in oil or transmission fluid?</li> </ul>	<p><b>Yes</b> If coolant is in the engine oil, GO to Engine. If coolant is in the transmission fluid, INSTALL a new radiator. REFER to Radiator, Cooling Fan and Shroud. REPAIR the transmission as necessary, REFER to transmission &amp; drivetrain.</p> <p><b>No</b> GO to A5.</p>
<b>A5</b>	<b>PRESSURE TEST THE ENGINE COOLING SYSTEM</b>	
	<ul style="list-style-type: none"> <li>Pressure test the cooling system. Refer to Component Tests, Pressure Test</li> <li>Does the engine cooling system leak?</li> </ul>	<p><b>Yes</b> REPAIR or INSTALL new components if leaking. TEST the system for normal operation.</p> <p><b>No</b> The cooling system is operational. GO to Symptom Chart.</p>

## Steps A3 - A5

## Test B

## PINPOINT TEST B: THE ENGINE OVERHEATS

Test Step		Result / Action to Take
<b>B1</b>	<b>CHECK THE ENGINE COOLANT LEVEL</b>	
	<p><b>NOTE:</b> If the engine is hot, allow the engine to cool before proceeding.</p> <ul style="list-style-type: none"> <li>Key in OFF position.</li> <li> <b>WARNING:</b> Never remove the pressure relief cap while the engine is operating or when the cooling system is hot. Failure to follow these instructions can result in damage to the cooling system or engine or personal injury. To avoid having scalding hot coolant or steam blow out of the degas bottle when removing the pressure relief cap, wait until the engine has cooled, then wrap a thick cloth around the pressure relief cap and turn it slowly. Step back while the pressure is released from the cooling system. When you are sure all the pressure has been released, turn and remove the pressure relief cap (still with a cloth).</li> <li>Check the engine coolant level at the degas bottle.</li> <li>Is the engine coolant OK?</li> </ul>	<p><b>Yes</b> GO to B2.</p> <p><b>No</b> REFILL the engine coolant at the degas bottle. GO to Pinpoint Test A.</p>
<b>B2</b>	<b>CHECK THE COOLANT CONDITION</b>	
	<ul style="list-style-type: none"> <li>Check the coolant for contaminants such as rust, corrosion, or discoloration.</li> <li>Is the coolant condition OK?</li> </ul>	<p><b>Yes</b> GO to B3.</p> <p><b>No</b> FLUSH the engine cooling system. TEST the system for normal operation.</p>

## Steps B1 - B2

Test Step		Result / Action to Take
<b>B3</b>	<b>CHECK FOR AN AIRFLOW OBSTRUCTION</b>	<b>Yes</b> REMOVE the obstruction. CLEAN the A/C condenser core and radiator. TEST the system for normal operation.  <b>No</b> GO to B4.
	<ul style="list-style-type: none"> <li>Inspect the A/C condenser core and radiator for obstructions such as leaves or dirt.</li> <li>Is there an obstruction?</li> </ul>	
<b>B4</b>	<b>CHECK THE THERMOSTAT OPERATION</b>	<b>Yes</b> INSTALL a new thermostat. TEST the system for normal operation.  <b>No</b> GO to B5.
	<ul style="list-style-type: none"> <li>Key in START position.</li> <li>Start the engine and allow it to run until the engine reaches operating temperature.</li> <li>Feel the inlet and outlet heater water hoses and the underside of the upper radiator hose.</li> <li>Are the upper radiator hose and the heater hoses cold?</li> </ul>	
<b>B5</b>	<b>CHECK THE COOLING FAN OPERATION</b>	<b>Yes</b> INSTALL a new coolant pump. TEST the system for normal operation.  <b>No</b> GO to Symptom Chart to diagnose cooling fans.
	<ul style="list-style-type: none"> <li>Using the diagnostic tool, command the cooling fans ON in low, medium and high speed.</li> <li>Do the cooling fans operate correctly?</li> </ul>	

## Steps B3 - B5

## Test C

## PINPOINT TEST C: THE ENGINE DOES NOT REACH NORMAL OPERATING TEMPERATURE

Test Step		Result / Action to Take
<b>C1</b>	<b>CHECK THE ENGINE TEMPERATURE</b>	<b>Yes</b> INSTALL a new thermostat. TEST the system for normal operation.  <b>No</b> REFER to Instrument Panel, Gauges & Warning indicators for diagnosis and testing of the engine coolant temperature gauge.
	<ul style="list-style-type: none"> <li>Key in START position.</li> <li>Start the engine and allow the engine to idle for 10 minutes.</li> <li>Key in OFF position.</li> <li>Feel the upper and lower radiator hoses.</li> <li>Are the upper and lower radiator hoses cold?</li> </ul>	

## Step C1

## Test D

## Pinpoint Test D: The Electric Cooling Fan(s) Is Inoperative In One Or More Speeds

## Normal Operation

Under normal operation, in low speed, voltage is supplied to cooling fan relay 2 through circuit 1823 (YE/BK). When the relay is energized, voltage is fed to the RH cooling fan motor through circuit 1825 (LG/YE). The voltage is then fed from the RH cooling fan motor by circuit 461 (OG), through cooling fan relay 3 and to cooling fan relay 1 through circuits 3850 (LG/VT) and 1826 (YE/RD). From the cooling fan relay, voltage is fed to the LH cooling fan motor by circuit 1824 (LG/VT). Ground for the cooling fan motors is provided from the cooling fan resistor through circuit 471 (OG/LG), cooling fan relay 4 and circuit 462 (VT) to the LH cooling fan motor.

Under normal operation and in medium speed, voltage is supplied to cooling fan relay 2 through circuit 1823 (YE/BK) and to cooling fan relay 1 through circuit 1822 (LB). When the relays are energized, voltage is fed to the RH cooling fan motor through circuit 1825 (LG/YE) and to the LH cooling fan motor through circuit 1824 (LG/VT). Ground for the cooling fan motors is provided from the cooling fan resistor through circuit 471 (OG/LG) to cooling fan relay 4 (LH) and 5 (RH). The LH cooling fan motor ground is received from cooling fan relay 4 through circuit 462 (VT). The RH cooling fan motor ground is received from cooling fan relay 5 through circuit 3828 (OG/BK), cooling fan relay 3 (energized) and circuit 461 (OG).

Under normal operation and in high speed, voltage is supplied to cooling fan relay 2 through circuit 1823 (YE/BK) and to cooling fan relay 1 through circuit 1822 (LB). When the relays are energized, voltage is fed to the RH cooling fan motor through circuit 1825 (LG/YE) and to the LH cooling fan motor through circuit 1824 (LG/VT). Ground for the cooling fan motors is provided through circuit 1205 (BK) to cooling fan relay 4 (LH) and 5 (RH). The LH cooling fan motor ground is received from cooling fan relay 4 (energized) through circuit 462 (VT). The RH cooling fan motor ground is received from cooling fan relay 5 (energized) through circuit 3828 (OG/BK), cooling fan relay 3 (energized) and circuit 461 (OG).

## Possible Causes

- ^ An open circuit 3850 (LG/VT), 1826 (YE/RD), 471 (OG/LG), 1205 (BK), 1823 (YE/BK), 1825 (LG/YE), 461 (OG), 3828 (OG/BK), 462 (VT), 1824 (LG/VT) or 1822 (LB).
- ^ A short to ground or short to voltage on circuit 3850 (LG/VT) or 1826 (YE/RD)
- ^ Cooling fan relay.

- ^ Cooling fan motor.
- ^ Cooling fan resistor.

Test Step		Result / Action to Take
<b>D1</b>	<b>CHECK OPERATION OF THE ELECTRIC COOLING FANS IN LOW AND MEDIUM</b>	<p><b>Yes</b> Carry out the cooling fan resistor component test in this section. If the resistor tests OK, GO to D2.</p> <p><b>No</b> If both fans are inoperative in low speed only, REPAIR circuit 3850 (LG/VT)/1826 (YE/RD) for an open. TEST the system for normal operation.</p> <p>If the LH fan is inoperative in low speed only, REPAIR circuit 3850 (LG/VT)/1826 (YE/RD) for a short to ground. TEST the system for normal operation.</p> <p>If the RH fan is inoperative in low speed only, REPAIR circuit 3850 (LG/VT)/1826 (YE/RD) for a short to voltage. TEST the system for normal operation.</p> <p>GO to D3.</p>
	<ul style="list-style-type: none"> <li>• Key in ON position.</li> <li>• Connect the diagnostic tool.</li> <li>• Using the diagnostic tool, command the cooling fans ON in low and medium speeds.</li> <li>• <b>Are both cooling fans inoperative in both speeds?</b></li> </ul>	
<b>D2</b>	<b>CHECK THE COOLING FAN RESISTOR GROUND CIRCUIT</b>	
	<ul style="list-style-type: none"> <li>• Key in OFF position.</li> <li>• Disconnect: Cooling Fan Resistor C1214.</li> </ul>	

### Steps D1 - D2

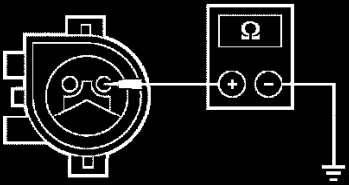
Test Step		Result / Action to Take
<b>D2</b>	<b>CHECK THE COOLING FAN RESISTOR GROUND CIRCUIT (Continued)</b> <ul style="list-style-type: none"> <li>Measure the resistance between the cooling fan resistor C1214-2, circuit 1205 (BK) and ground.</li> </ul>  <p>A0013644</p> <ul style="list-style-type: none"> <li><b>If the resistance less than 5 ohms?</b></li> </ul>	<p><b>Yes</b> REPAIR circuit 471 (OG/LG). TEST the system for normal operation.</p> <p><b>No</b> REPAIR circuit 1205 (BK). TEST the system for normal operation.</p>
<b>D3</b>	<b>CHECK OPERATION OF THE ELECTRIC COOLING FANS IN MEDIUM AND HIGH</b> <ul style="list-style-type: none"> <li>Using the diagnostic tool, command the cooling fans ON in medium and high speeds.</li> <li><b>Is only one cooling fan inoperative in both speeds?</b></li> </ul>	<p><b>Yes</b> RH cooling fan, GO to D4. LH cooling fan, GO to D8.</p> <p><b>No</b> If both fans are inoperative in high speed only, REPAIR circuit 1205 (BK) for an open. TEST the system for normal operation.</p> <p>If one fan is inoperative in medium speed only, carry out the relay component test on cooling fan relay 4 (LH) or 5 (RH). If the relay tests OK, REPAIR circuit 471 (OG/LG) for an open. TEST the system for normal operation.</p> <p>If one fan is inoperative in high speed only, carry out the relay component test on cooling fan relay 4 (LH) or 5 (RH). If the relay tests OK, REPAIR circuit 1205 (BK) for an open. TEST the system for normal operation.</p>
<b>D4</b>	<b>CHECK THE VOLTAGE TO THE RH ELECTRIC COOLING FAN</b> <ul style="list-style-type: none"> <li>Key in OFF position.</li> <li>Disconnect: RH Cooling Fan Motor C1077.</li> <li>Key in ON position.</li> <li>Using the diagnostic tool, command the cooling fans ON high speed.</li> </ul>	

Steps D2 - D3

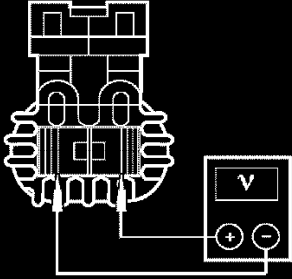
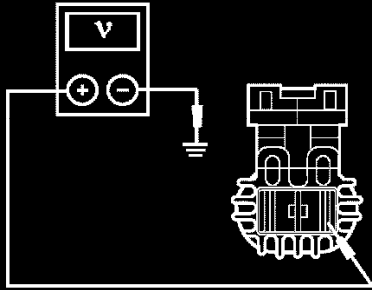
Test Step		Result / Action to Take
<b>D4</b>	<b>CHECK THE VOLTAGE TO THE RH ELECTRIC COOLING FAN (Continued)</b> <ul style="list-style-type: none"> <li>Measure the voltage between the RH cooling fan motor C1077-1, circuit 1825 (LG/YE) and C1077-2, circuit 461 (OG).</li> </ul>  <p>A0034146</p> <ul style="list-style-type: none"> <li>Is the voltage greater than 10 volts?</li> </ul>	<p><b>Yes</b> INSTALL a new RH cooling fan motor. TEST the system for normal operation.</p> <p><b>No</b> GO to D5.</p>
<b>D5</b>	<b>CHECK THE VOLTAGE TO THE RH ELECTRIC COOLING FAN</b> <ul style="list-style-type: none"> <li>Measure the voltage between the RH cooling fan motor C1077-1, circuit 1825 (LG/YE) and ground.</li> </ul>  <p>AM1825-A</p> <ul style="list-style-type: none"> <li>Is the voltage greater than 10 volts?</li> </ul>	<p><b>Yes</b> GO to D7.</p> <p><b>No</b> GO to D6.</p>
<b>D6</b>	<b>CHECK CIRCUIT 1823 (YE/BK)</b> <ul style="list-style-type: none"> <li>Key in OFF position.</li> <li>Disconnect: Cooling Fan Relay 2.</li> <li>Key in ON position.</li> </ul>	

Steps D4 - D6

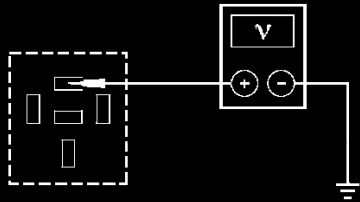
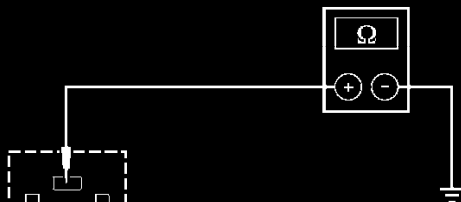
Test Step		Result / Action to Take
<b>D6</b>	<b>CHECK CIRCUIT 1823 (YE/BK) (Continued)</b>	
	<ul style="list-style-type: none"> <li>Measure the voltage between the cooling fan relay 2 pin 5, circuit 1823 (YE/BK) and ground.</li> </ul>  <p>A0013861</p> <ul style="list-style-type: none"> <li>Is the voltage greater than 10 volts?</li> </ul>	<p><b>Yes</b> Carry out the relay component test on cooling fan relay 2. If the relay tests OK, REPAIR circuit 1825 (LG/YE) for an open. TEST the system for normal operation.</p> <p><b>No</b> REPAIR circuit 1823 (YE/BK) for an open. TEST the system for normal operation.</p>
<b>D7</b>	<b>CHECK CIRCUIT 3828 (OG/BK)</b>	
	<ul style="list-style-type: none"> <li>Key in OFF position.</li> <li>Disconnect: Cooling Fan Relay 3.</li> <li>Key in ON position.</li> <li>Using the diagnostic tool, command the cooling fans ON high speed.</li> <li>Measure the resistance between cooling fan relay 3 pin 87, circuit 3828 (OG/BK) and ground.</li> </ul>  <p>A0020416</p> <ul style="list-style-type: none"> <li>Is the resistance less than 5 ohms?</li> </ul>	<p><b>Yes</b> Carry out the relay component test on cooling fan relay 3. If the relay tests OK, REPAIR circuit 461 (OG) for an open. TEST the system for normal operation.</p> <p><b>No</b> Carry out the relay component test on cooling fan relay 5. If the relay tests OK, REPAIR circuit 3828 (OG/BK) for an open. TEST the system for normal operation.</p>
<b>D8</b>	<b>CHECK THE VOLTAGE TO THE LH ELECTRIC COOLING FAN</b>	
	<ul style="list-style-type: none"> <li>Key in OFF position.</li> <li>Disconnect: LH Cooling Fan Motor C1074.</li> <li>Key in ON position.</li> <li>Using the diagnostic tool, command the cooling fans ON high speed.</li> </ul>	

## Steps D6 - D8

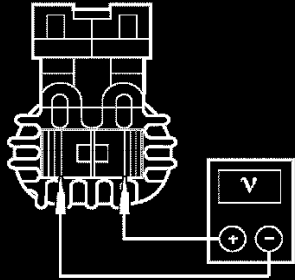
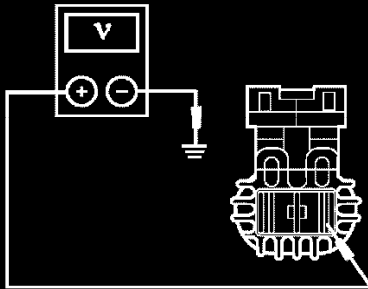
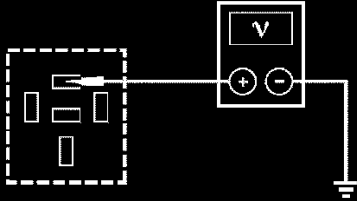
Test Step		Result / Action to Take
<b>D8</b>	<b>CHECK THE VOLTAGE TO THE LH ELECTRIC COOLING FAN (Continued)</b> <ul style="list-style-type: none"> <li>Measure the voltage between the LH cooling fan motor C1074-1, circuit 1825 (LG/YE) and C1074-2, circuit 461 (OG).</li> </ul>  <p>A0034146</p> <ul style="list-style-type: none"> <li>Is the voltage greater than 10 volts?</li> </ul>	<p><b>Yes</b> INSTALL a new LH cooling fan motor. TEST the system for normal operation.</p> <p><b>No</b> GO to D9.</p>
<b>D9</b>	<b>CHECK THE VOLTAGE TO THE LH ELECTRIC COOLING FAN</b> <ul style="list-style-type: none"> <li>Measure the voltage between the LH cooling fan motor C1074-1, circuit 1824 (LG/VT) and ground.</li> </ul>  <p>AM1825-A</p> <ul style="list-style-type: none"> <li>Is the voltage greater than 10 volts?</li> </ul>	<p><b>Yes</b> Carry out the relay component test on cooling fan relay 42. If the relay tests OK, REPAIR circuit 462 (VT) for an open. TEST the system for normal operation.</p> <p><b>No</b> GO to D10.</p>
<b>D10</b>	<b>CHECK CIRCUIT 1822 (LB)</b> <ul style="list-style-type: none"> <li>Key in OFF position.</li> <li>Disconnect: Cooling Fan Relay 1.</li> <li>Key in ON position.</li> <li>Measure the voltage between cooling fan relay 2 pin 5, circuit 1822 (LB) and ground.</li> </ul>  <p>A0013861</p> <ul style="list-style-type: none"> <li>Is the voltage greater than 10 volts?</li> </ul>	<p><b>Yes</b> Carry out the relay component test on cooling fan relay 1. If the relay tests OK, REPAIR circuit 1824 (LG/VT) for an open. TEST the system for normal operation.</p> <p><b>No</b> REPAIR circuit 1822 (LB) for an open. TEST the system for normal operation.</p>

### Steps D8 - D10

**NOTE:** Before carrying out the test, diagnose any PCM DTCs.

## Test E

### Pinpoint Test E: The Electric Cooling Fan(s) Stays On All The Time

#### Normal Operation

Under normal operation, in low speed, voltage is supplied to cooling fan relay 2 through circuit 1823 (YE/BK). When the relay is energized, voltage is fed to the RH cooling fan motor through circuit 1825 (LG/YE). The voltage is then fed from the RH cooling fan motor by circuit 461 (OG), through cooling fan relay 3 and to cooling fan relay 1 through circuits 3850 (LG/VT) and 1826 (YE/RD). Cooling fan relay voltage is fed to the LH cooling fan motor by circuit 1824 (LG/VT). Ground for the cooling fan motors is provided from the cooling fan resistor through circuit 471

(OG/LG), cooling fan relay 4 and circuit 462 (VT) to the LH cooling fan motor.

Under normal operation and in medium speed, voltage is supplied to cooling fan relay 2 through circuit 1823 (YE/BK) and to cooling fan relay 1 through circuit 1822 (LB). When the relays are energized, voltage is fed to the RH cooling fan motor through circuit 1825 (LG/YE) and to the LH cooling fan motor through circuit 1824 (LG/VT). Ground for the cooling fan motors is provided from the cooling fan resistor through circuit 471 (OG/LG) to cooling fan relay 4 (LH) and 5 (RH). The LH cooling fan motor ground is received from cooling fan relay 4 through circuit 462 (VT). The RH cooling fan motor ground is received from cooling fan relay 5 through circuit 3828 (OG/BK), cooling fan relay 3 (energized) and circuit 461 (OG).

Under normal operation and in high speed, voltage is supplied to cooling fan relay 2 through circuit 1823 (YE/BK) and to cooling fan relay 1 through circuit 1822 (LB). When the relays are energized, voltage is fed to the RH cooling fan motor through circuit 1825 (LG/YE) and to the LH cooling fan motor through circuit 1824 (LG/VT). Ground for the cooling fan motors is provided through circuit 1205 (BK) to cooling fan relay 4 (LH) and 5 (RH). The LH cooling fan motor ground is received from cooling fan relay 4 (energized) through circuit 462 (VT). The RH cooling fan motor ground is received from cooling fan relay 5 (energized) through circuit 3828 (OG/BK), cooling fan relay 3 (energized) and circuit 461 (OG).

#### Possible Causes

- ^ A short to voltage on circuit 1825 (LG/YE) or 1824 (LG/VT).
- ^ Cooling fan relay.

Test Step		Result / Action to Take
<b>E1</b>	<b>CHECK OPERATION OF THE ELECTRIC COOLING FANS</b>	<b>Yes</b> RH cooling fan, GO to E2. LH cooling fan, GO to E3. <b>No</b> GO to Pinpoint Test F.
	<ul style="list-style-type: none"> <li>• Key in ON position.</li> <li>• Observe fan operation.</li> <li>• Is only one fan running?</li> </ul>	
<b>E2</b>	<b>CHECK CIRCUIT 1825 (LG/YE) FOR A SHORT TO VOLTAGE</b>	
	<ul style="list-style-type: none"> <li>• Key in OFF position.</li> <li>• Disconnect: RH Cooling Fan Motor C1077.</li> <li>• Key in ON position.</li> </ul>	

#### Steps E1 - E2

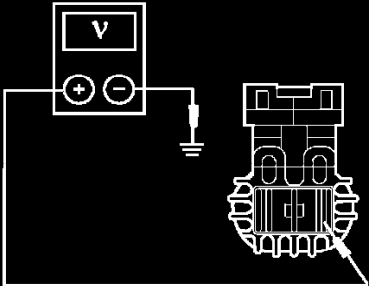
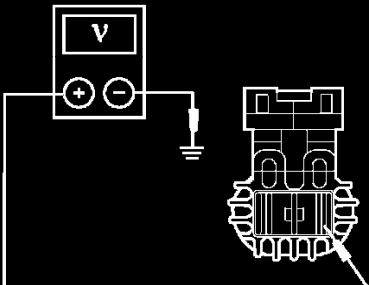
Test Step		Result / Action to Take
<b>E2</b>	<b>CHECK CIRCUIT 1825 (LG/YE) FOR A SHORT TO VOLTAGE (Continued)</b>	
	<ul style="list-style-type: none"> <li>Measure the voltage between the RH cooling fan motor C1077-1, circuit 1825 (LG/YE) and ground.</li> </ul>  <p>AM1825-A</p> <ul style="list-style-type: none"> <li>Is the voltage greater than 10 volts?</li> </ul>	<p><b>Yes</b> REPAIR circuit 1825 (LG/YE) for a short to voltage. TEST the system for normal operation.</p> <p><b>No</b> INSTALL a new cooling fan relay 2. TEST the system for normal operation.</p>
<b>E3</b>	<b>CHECK CIRCUIT 1824 (LG/VT) FOR A SHORT TO VOLTAGE</b>	
	<ul style="list-style-type: none"> <li>Key in OFF position.</li> <li>Disconnect: LH Cooling Fan Motor C1074.</li> <li>Key in ON position.</li> <li>Measure the voltage between the LH cooling fan motor C1074-1, circuit 1824 (LG/VT) and ground.</li> </ul>  <p>AM1825-A</p> <ul style="list-style-type: none"> <li>Is the voltage greater than 10 volts?</li> </ul>	<p><b>Yes</b> REPAIR circuit 1824 (LG/VT) for a short to voltage. TEST the system for normal operation.</p> <p><b>No</b> INSTALL a new cooling fan relay 1. TEST the system for normal operation.</p>

### Steps E2 - E3

**NOTE:** Before carrying out the test, diagnose any PCM DTCs.

## Test F

### Pinpoint Test F: The Electric Cooling Fan(s) Incorrect Operation

#### Normal Operation

Under normal operation and in low speed, voltage is supplied to cooling fan relay 2 through circuit 1823 (YE/BK). When the relay is energized, voltage is fed to the RH cooling fan motor through circuit 1825 (LG/YE). The voltage is then fed from the RH cooling fan motor by circuit 461 (OG), through cooling fan relay 3 and then to cooling fan relay 1 through circuits 3850 (LG/VT) and 1826 (YE/RD). Cooling fan relay voltage is fed to the LH cooling fan motor by circuit 1824 (LG/VT). Ground for the cooling fan motors is provided from the cooling fan resistor through circuit 471 (OG/LG), cooling fan relay 4 and through circuit 462 (VT) to the LH cooling fan motor.

Under normal operation and in medium speed, voltage is supplied to cooling fan relay 2 through circuit 1823 (YE/BK) and to cooling fan relay 1 through circuit 1822 (LB). When the relays are energized, voltage is fed to the RH cooling fan motor through circuit 1825 (LG/YE) and to the LH cooling fan motor through circuit 1824 (LG/VT). Ground for the cooling fan motors is provided from the cooling fan resistor through circuit 471 (OG/LG) to cooling fan relay 4 (LH) and 5 (RH). The LH cooling fan motor ground is received from cooling fan relay 4 through circuit 462 (VT). The RH cooling fan motor ground is received from cooling fan relay 5 through circuit 3828 (OG/BK), cooling fan relay 3 (energized) and circuit 461 (OG).

Under normal operation and in high speed, voltage is supplied to the cooling fan relay 2 through circuit 1823 (YE/BK) and to cooling fan relay 1 through circuit 1822 (LB). When the relays are energized, voltage is fed to the RH cooling fan motor through circuit 1825 (LG/YE) and to the LH cooling fan motor through circuit 1824 (LG/VT). Ground for the cooling fan motors is provided through circuit 1205 (BK) to cooling fan relay 4 (LH) and 5 (RH). The LH cooling fan motor ground is received from cooling fan relay 4 (energized) through circuit 462 (VT). The RH cooling fan motor ground is received from cooling fan relay 5 (energized) through circuit 3828 (OG/BK), cooling fan relay 3 (energized) and circuit 461 (OG).

#### Possible Causes

- ^ A short to ground on circuit 471 (OG/LG), 461 (OG), 3828 (OG/BK) or 462 (VT).
- ^ Cooling fan relay.

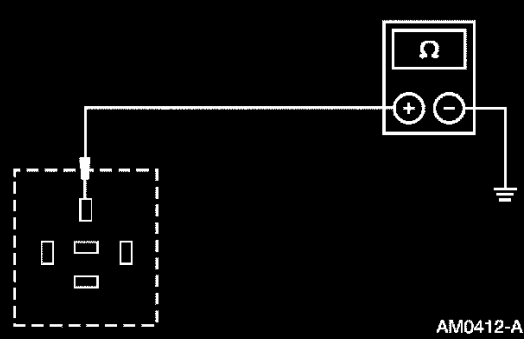
Test Step		Result / Action to Take
<b>F1</b>	<b>CHECK CIRCUIT 461 (OG) FOR A SHORT TO GROUND</b> <ul style="list-style-type: none"> <li>• Disconnect: RH Cooling Fan Motor C1077.</li> <li>• Disconnect: Cooling Fan Relay 3.</li> <li>• Measure the resistance between the cooling fan relay 3 pin 30, circuit 461 (OG) and ground.</li> </ul>  <p style="text-align: right;">AM0412-A</p> <ul style="list-style-type: none"> <li>• Is the resistance greater than 10,000 ohms?</li> </ul>	<p><b>Yes</b> GO to F2.</p> <p><b>No</b> REPAIR circuit 461 (OG) for a short to ground. TEST the system for normal operation.</p>
<b>F2</b>	<b>CHECK CIRCUIT 3828 (OG/BK) FOR A SHORT TO GROUND</b> <ul style="list-style-type: none"> <li>• Disconnect: Cooling Fan Relay 5.</li> </ul>	

Steps F1 - F2

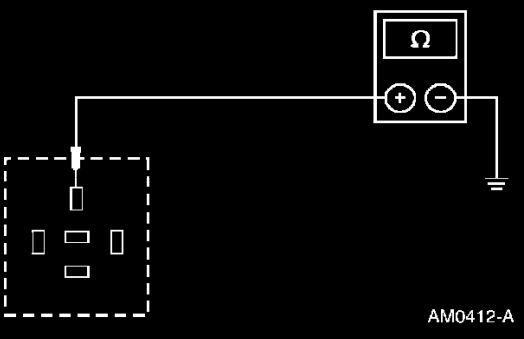
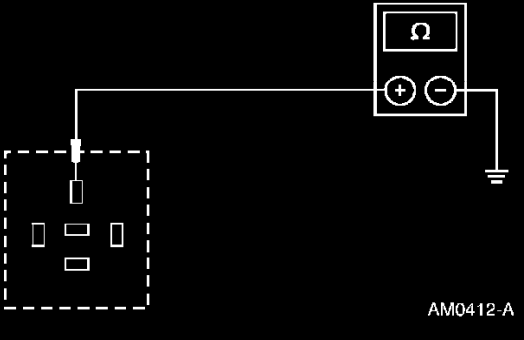
Test Step		Result / Action to Take
<b>F2</b>	<b>CHECK CIRCUIT 3828 (OG/BK) FOR A SHORT TO GROUND (Continued)</b> <ul style="list-style-type: none"> <li>• Measure the resistance between the cooling fan relay 5 pin 30, circuit 3828 (OG/BK) and ground.</li> </ul>  <p style="text-align: right;">AM0412-A</p> <ul style="list-style-type: none"> <li>• Is the resistance greater than 10,000 ohms?</li> </ul>	<p><b>Yes</b> Carry out the relay component test on cooling fan relay 5. If the relay tests OK, GO to F3.</p> <p><b>No</b> REPAIR circuit 3828 (OG/BK) for a short to ground. TEST the system for normal operation.</p>
<b>F3</b>	<b>CHECK CIRCUIT 462 (VT) FOR A SHORT TO GROUND</b> <ul style="list-style-type: none"> <li>• Disconnect: LH Cooling Fan Motor C1074.</li> <li>• Disconnect: Cooling Fan Relay 4.</li> <li>• Measure the resistance between the cooling fan relay 4 pin 30, circuit 462 (VT) and ground.</li> </ul>  <p style="text-align: right;">AM0412-A</p> <ul style="list-style-type: none"> <li>• Is the resistance greater than 10,000 ohms?</li> </ul>	

Steps F2 - F3

**NOTE:** Before carrying out the test, diagnose any PCM DTCs.