

Power and Ground Distribution: Electrical Diagrams

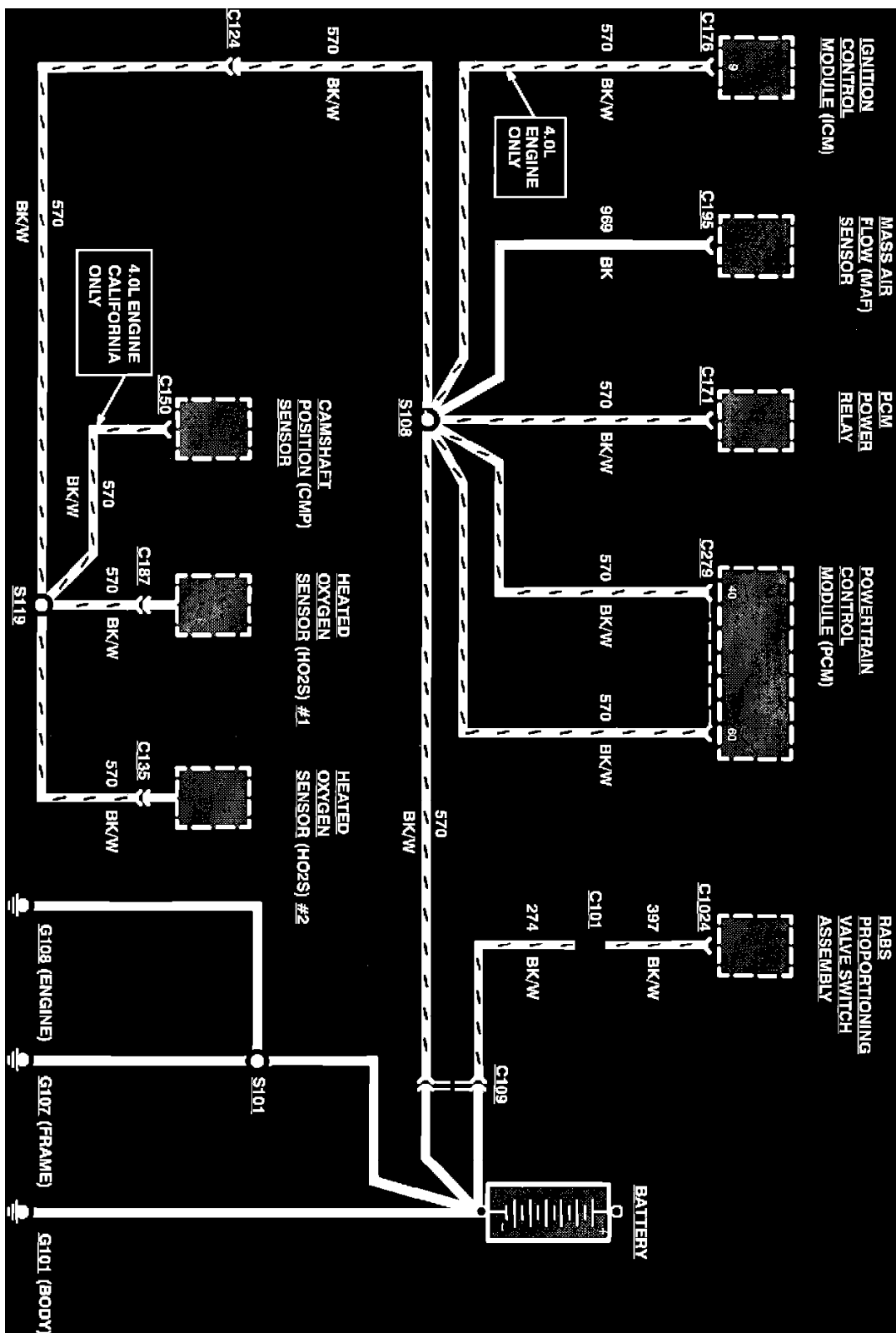

Grounds

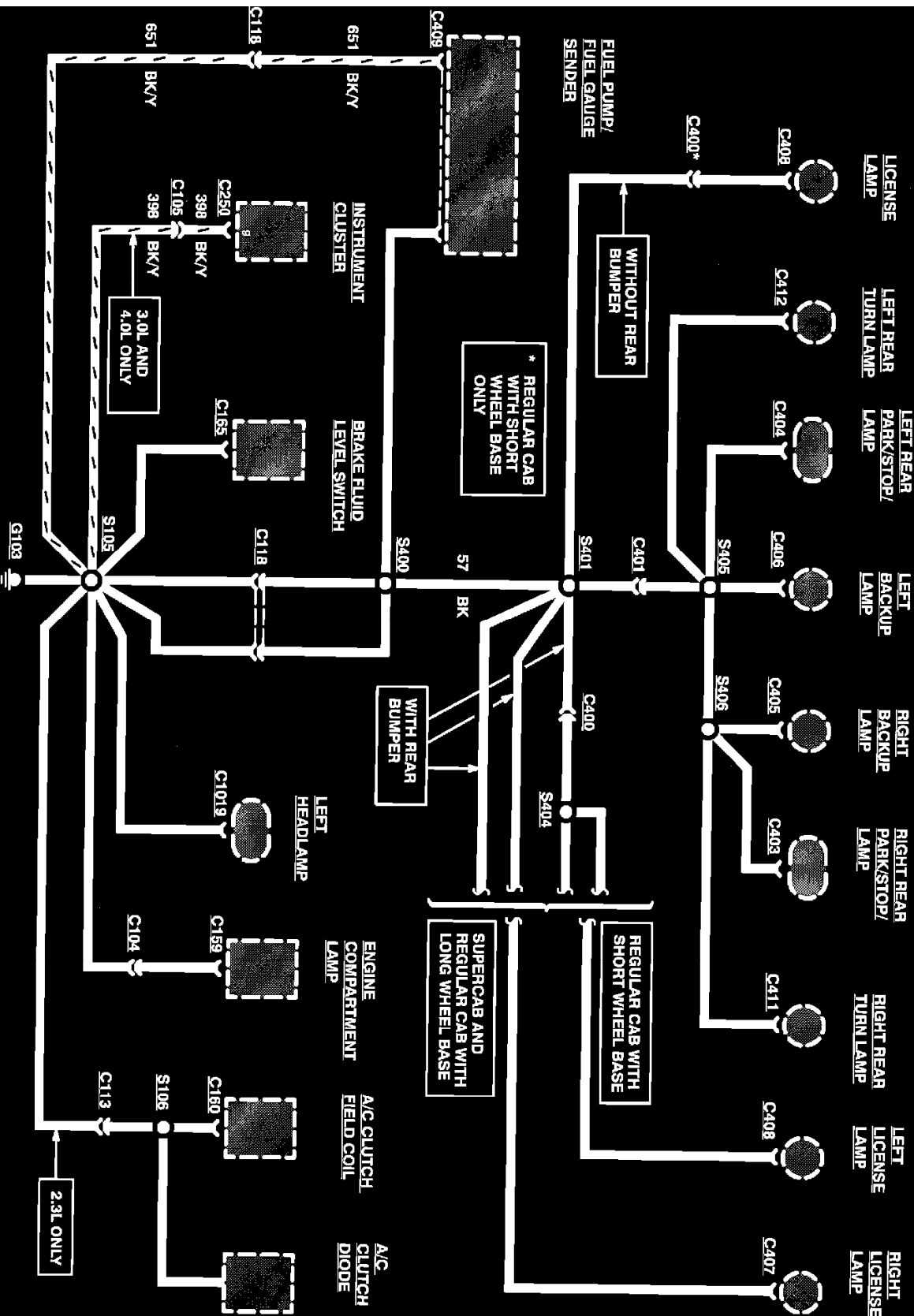

Grounds

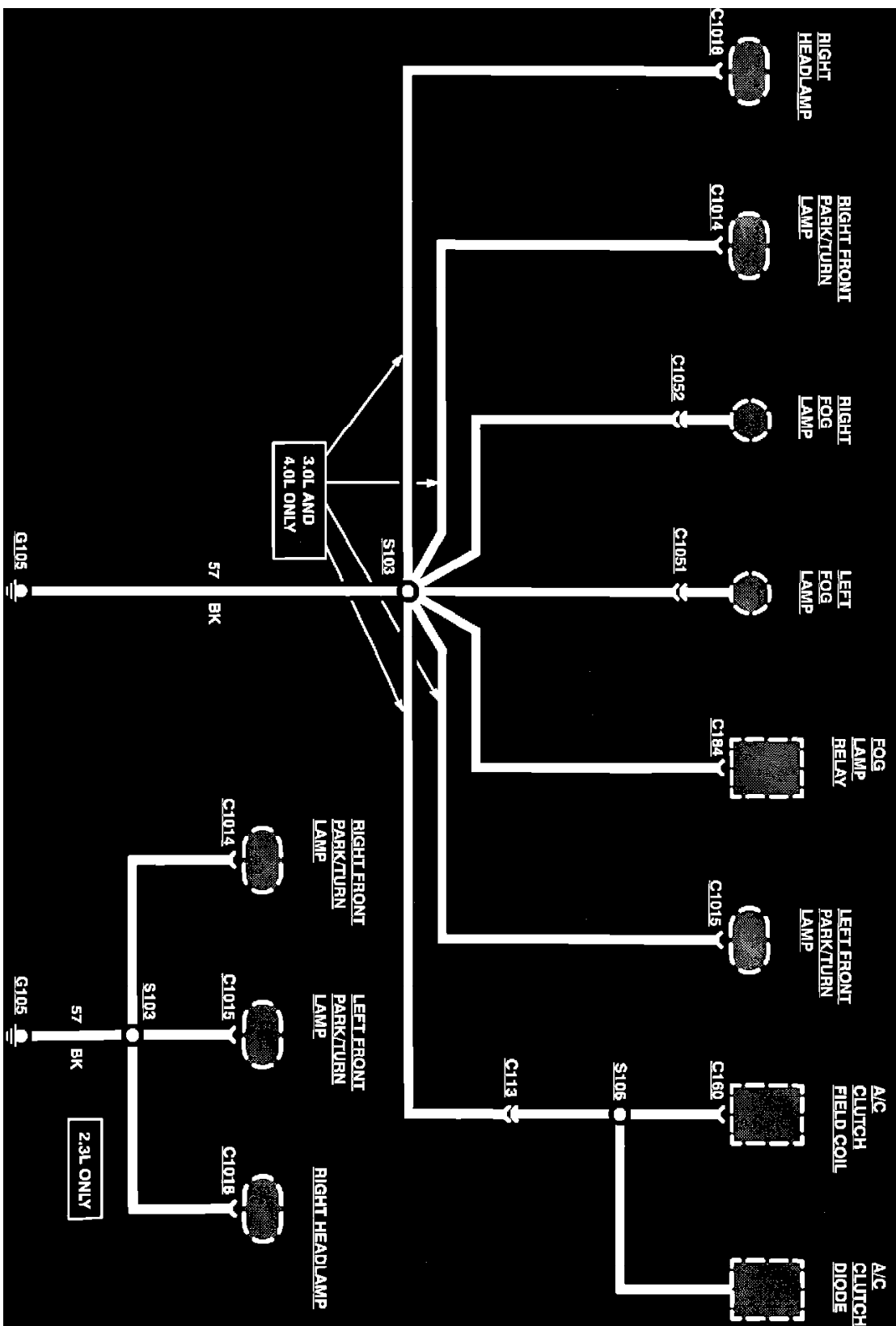

Grounds

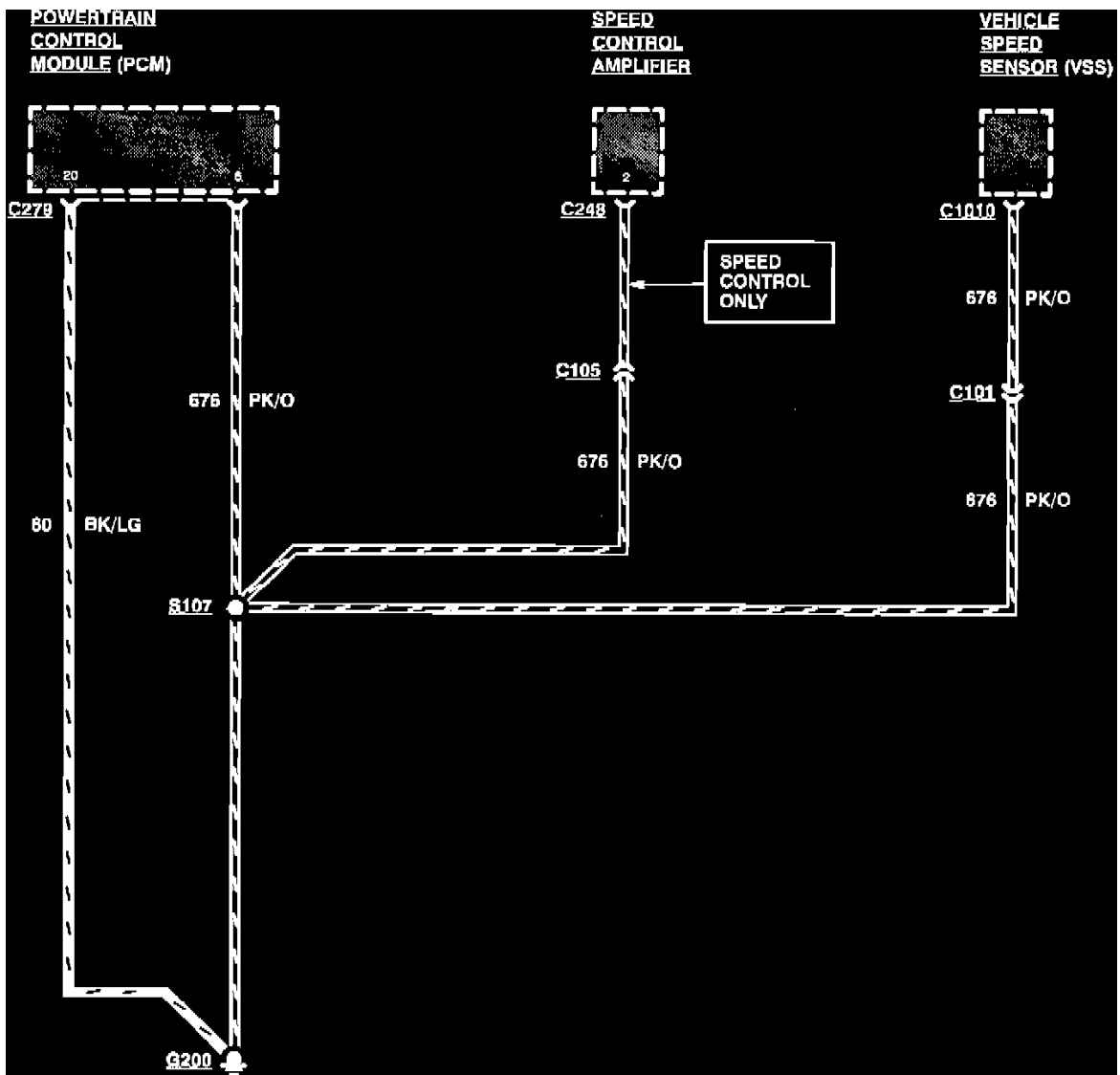

Grounds

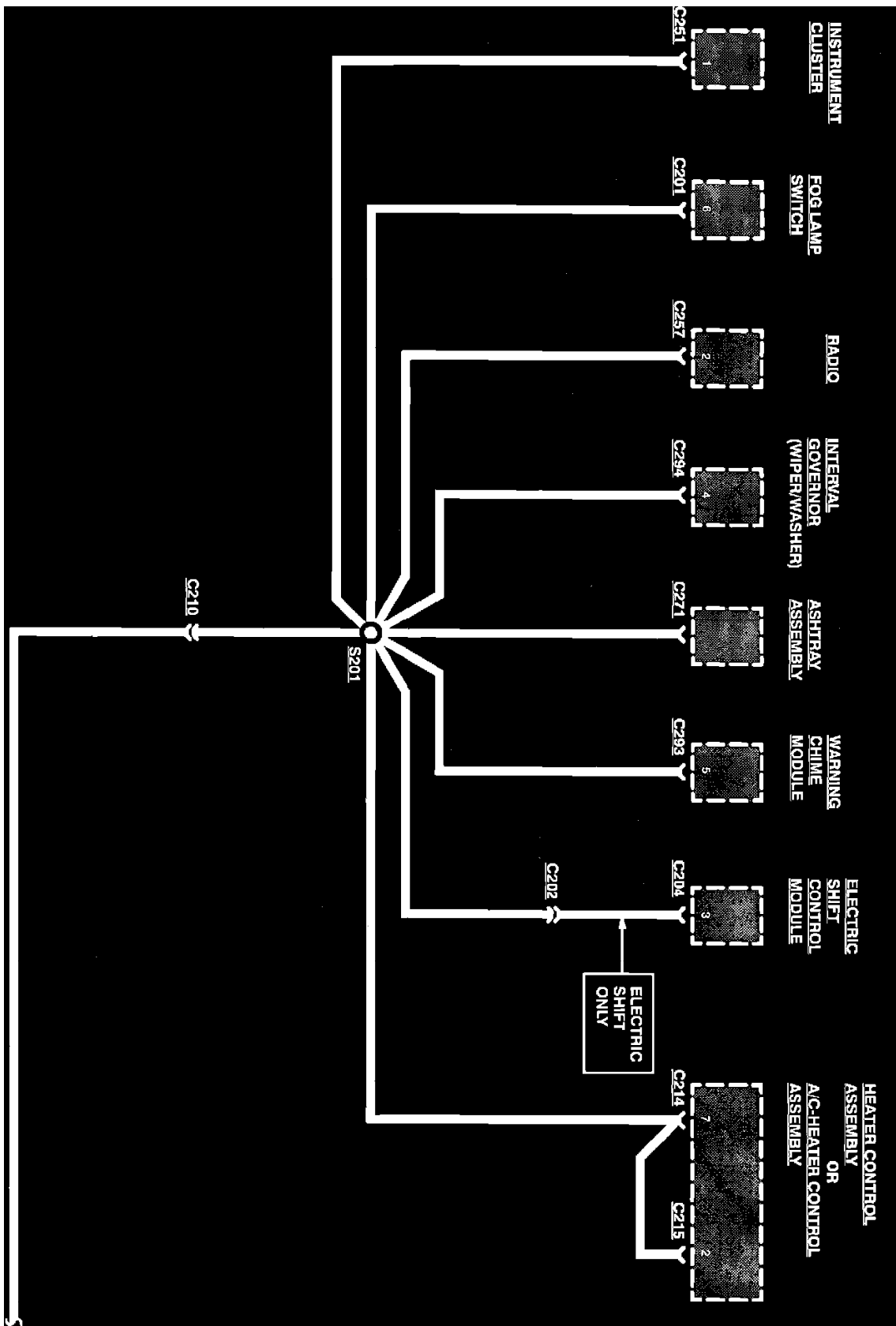

Grounds

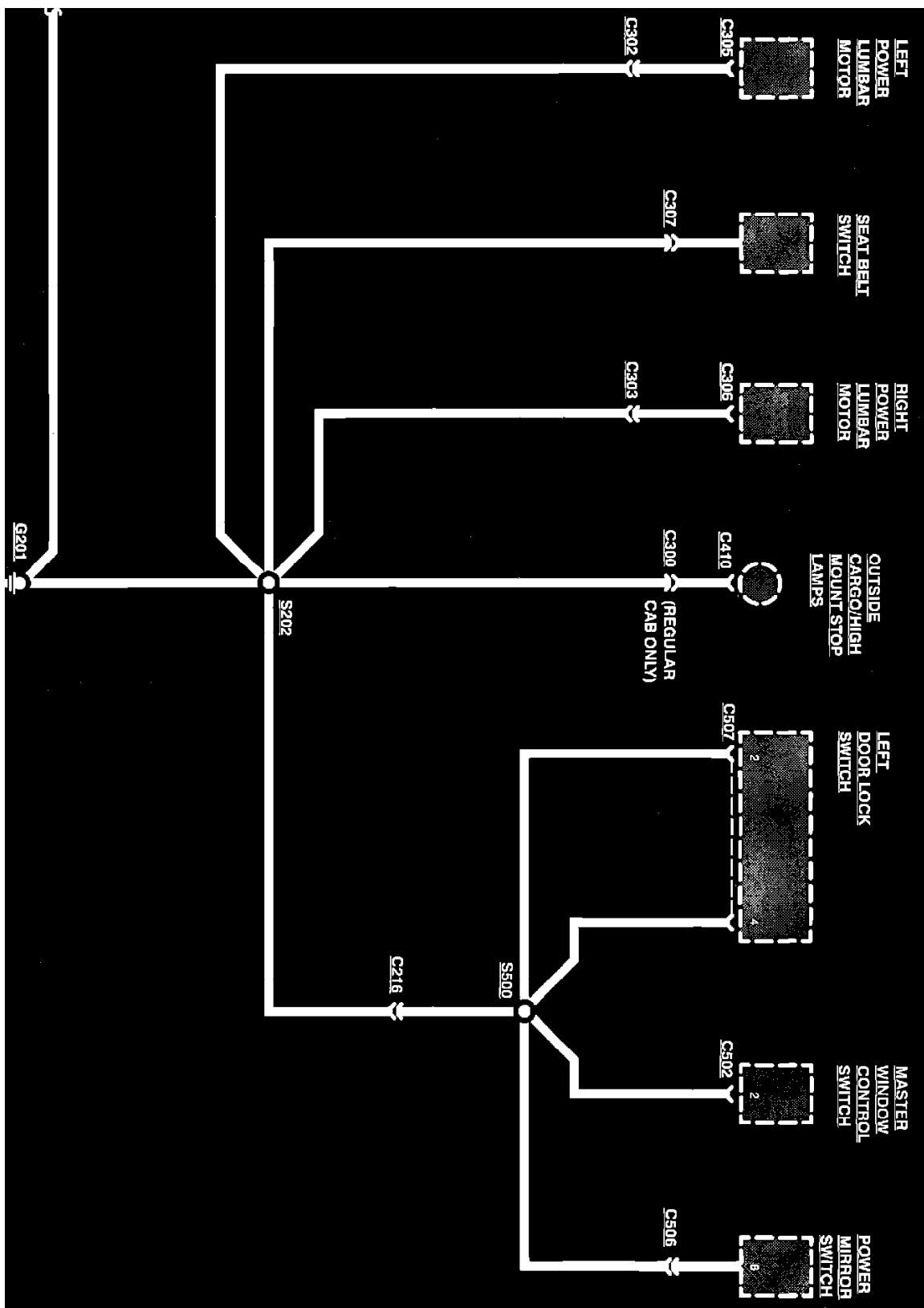

Grounds

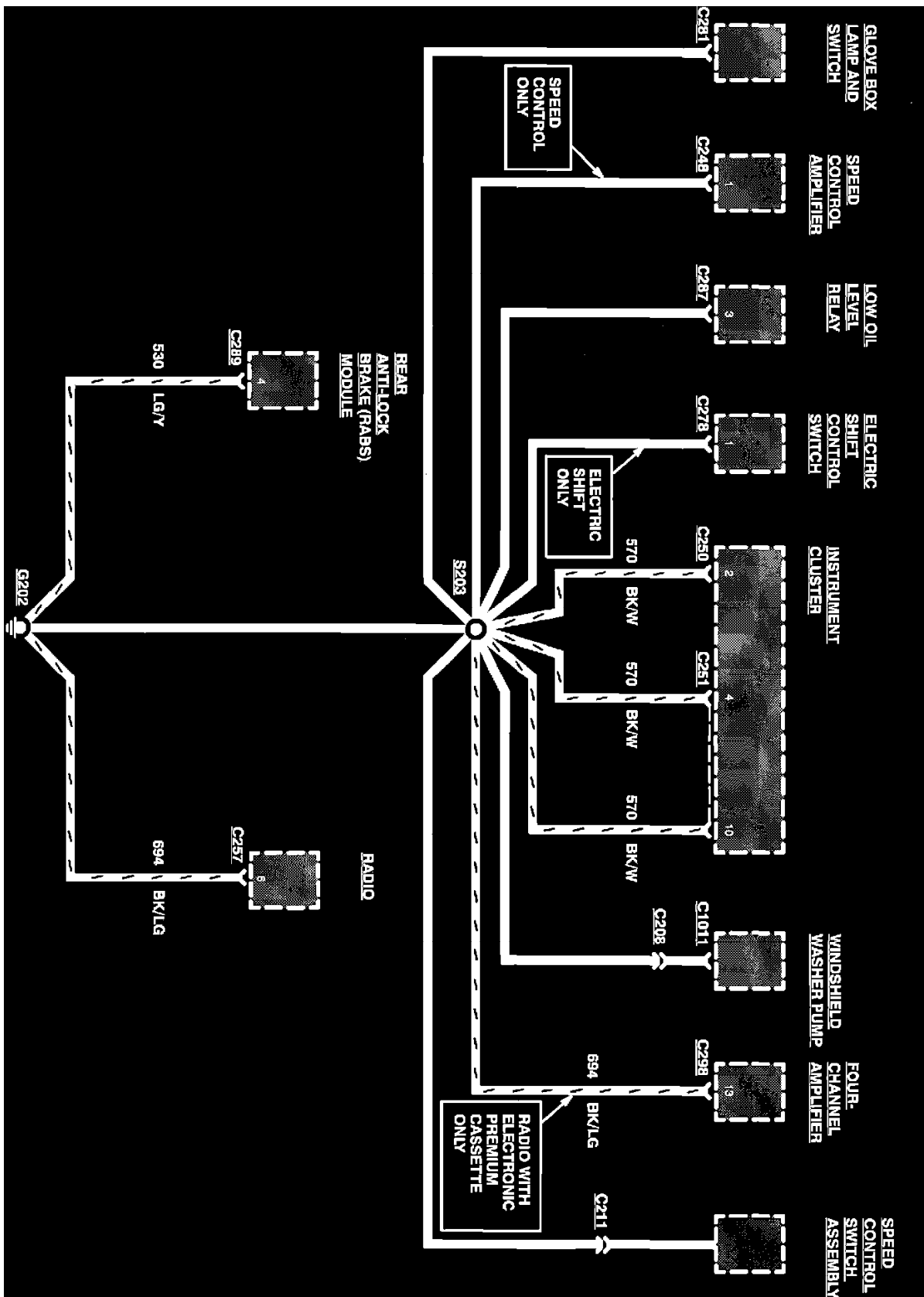

Grounds

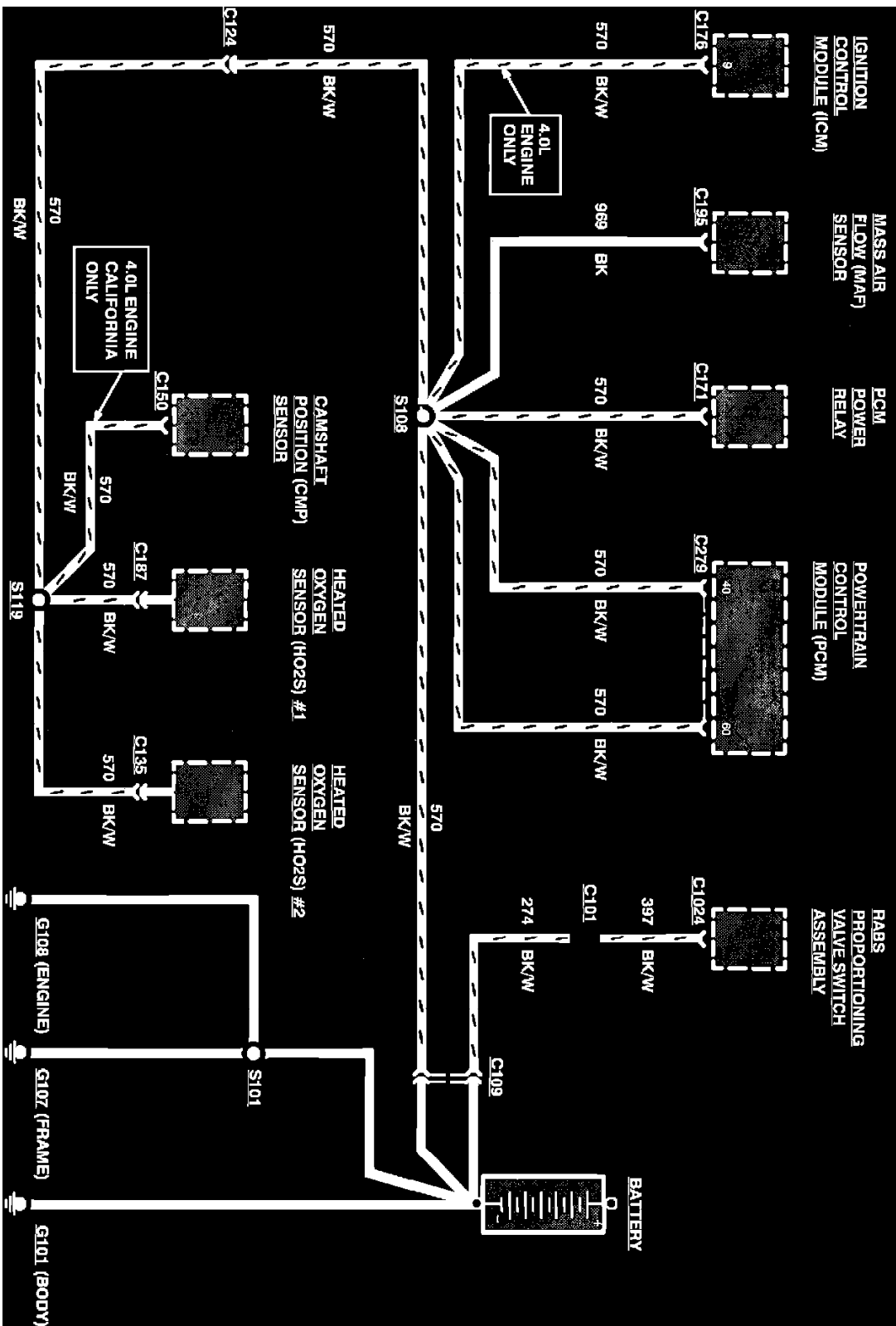

Grounds

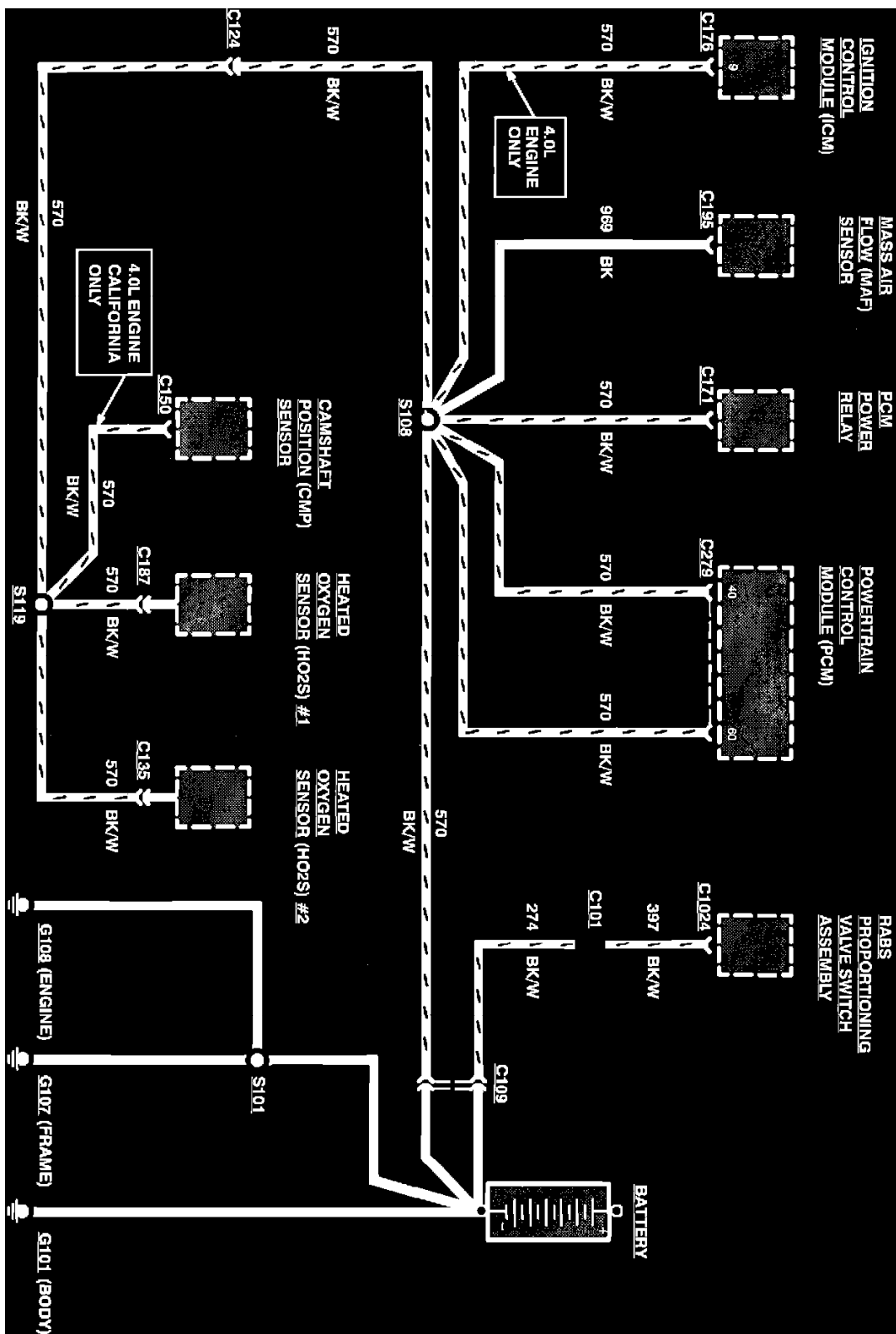

Grounds

Circuit-to-Fuse Cross Reference

Circuit Breaker 12 of Fuse Panel	Fuse PNL (60A Maxi)
Daytime Running Lamp Module (2 of 2 Power Feeds)	Fuse HOOD LAMP/DAYTIME RUNNING LAMPS
Electric Shift Control Module (1 of 2 Power Feeds)	Fuse ELEC.SHIFT
Fog Lamp Relay (1 of 2 Power Feeds)	Fuse FOG LAMP
Fuel Pump Relay (1 of 2 Power Feeds)	Fuse FUEL PUMP
Fuse 1 of Fuse Panel	Fuse PNL (40A Maxi)
Fuse 10 of Fuse Panel	Fuse PNL (40A Maxi)
Fuse 16 of Fuse Panel	Fuse PNL (60A Maxi)

Fuse 4 of Fuse Panel	Fuse PNL (60A Maxi)
Fuse 8 of Fuse Panel	Fuse PNL (60A Maxi)
Hood Lamp	Fuse HOOD LAMP/DAYTIME RUNNING LAMPS
Ignition Switch	Fuse IGN
Integral Alternator/Regulator (1 of 2 Power Feeds)	Fuse ALTERNATOR
Left Power Door Lock Switch	Fuse PWR LCKS
Main Light Switch (Headlamp and Fog Lamp Relay Power Feeds)	Fuse PNL (40A Maxi)
PCM	Fuse EEC PWR
PCM Relay (1 of 2 Power Feeds)	Fuse EEC PWR
PCM Relay (2 of 2 Power Feeds from Ignition Switch)	Fuse PCM POWER DIODE
Right Power Door Lock Switch	Fuse PWR LCKS

Fuse ALTERNATOR

Fuse ALTERNATOR - protects the following circuit:

- Integral Alternator/Regulator (1 of 2 Power Feeds)

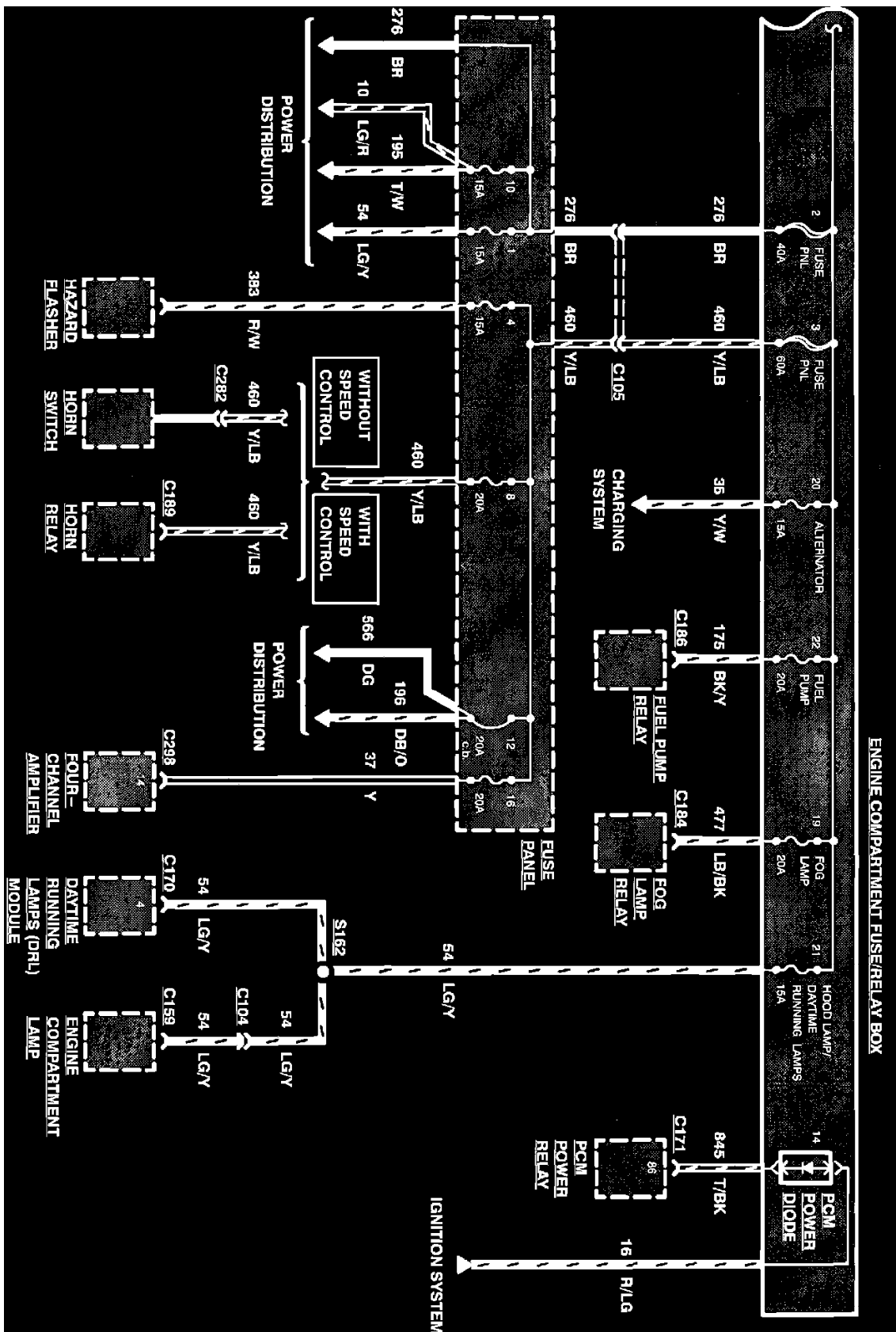

Power Distribution

Fuse EEC PWR

Fuse EEC PWR - protects the following circuits:

- PCM
- PCM Relay (1 of 2 Power Feeds)

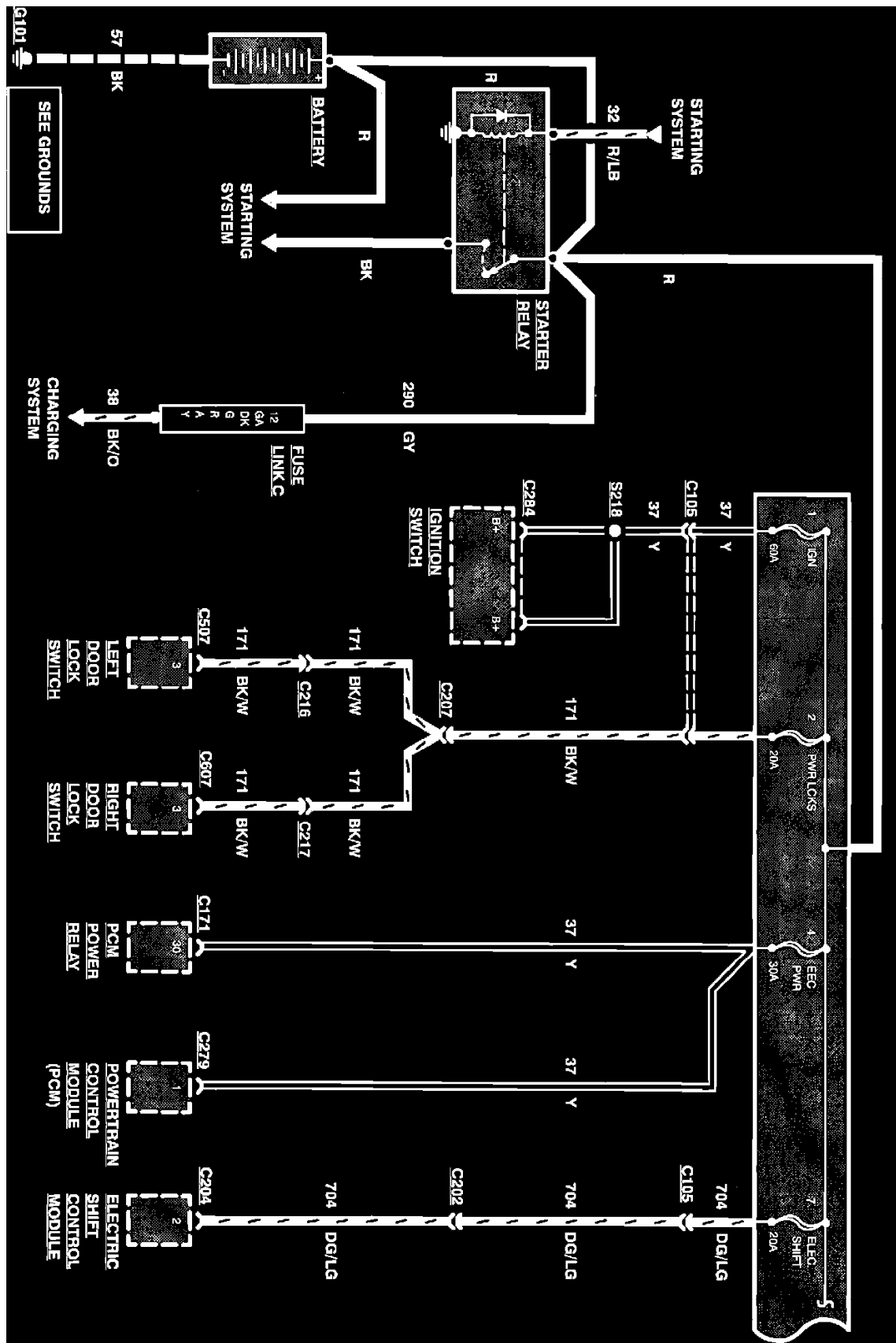

Power Distribution

Fuse ELEC.SHIFT

Fuse ELEC.SHIFT - protects the following circuit:

- Electric Shift Control Module (1 of 2 Power Feeds)

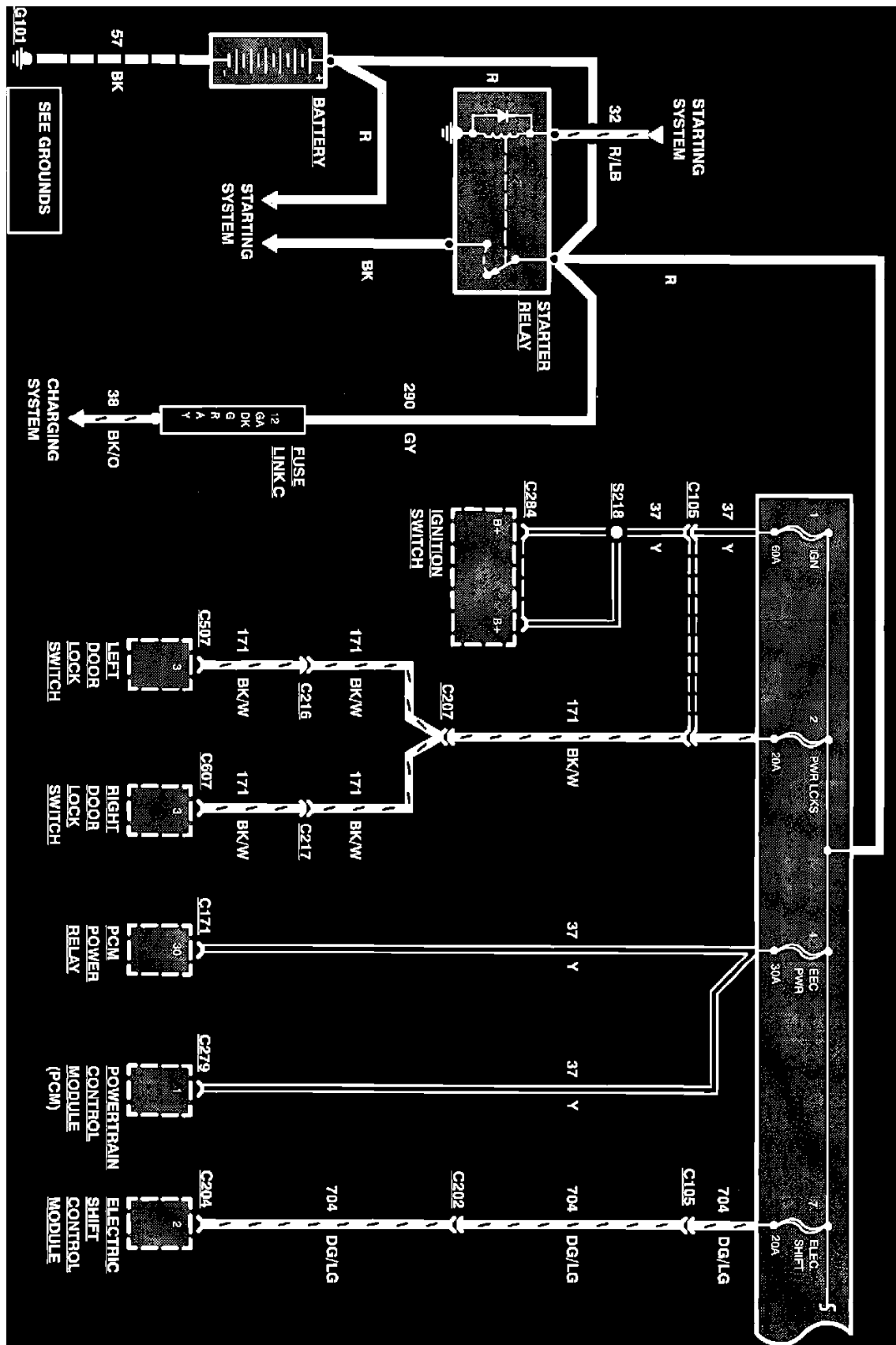

Power Distribution

Fuse FOG LAMP

Fuse FOG LAMP - protects the following circuit:

- Fog Lamp Relay (1 of 2 Power Feeds)

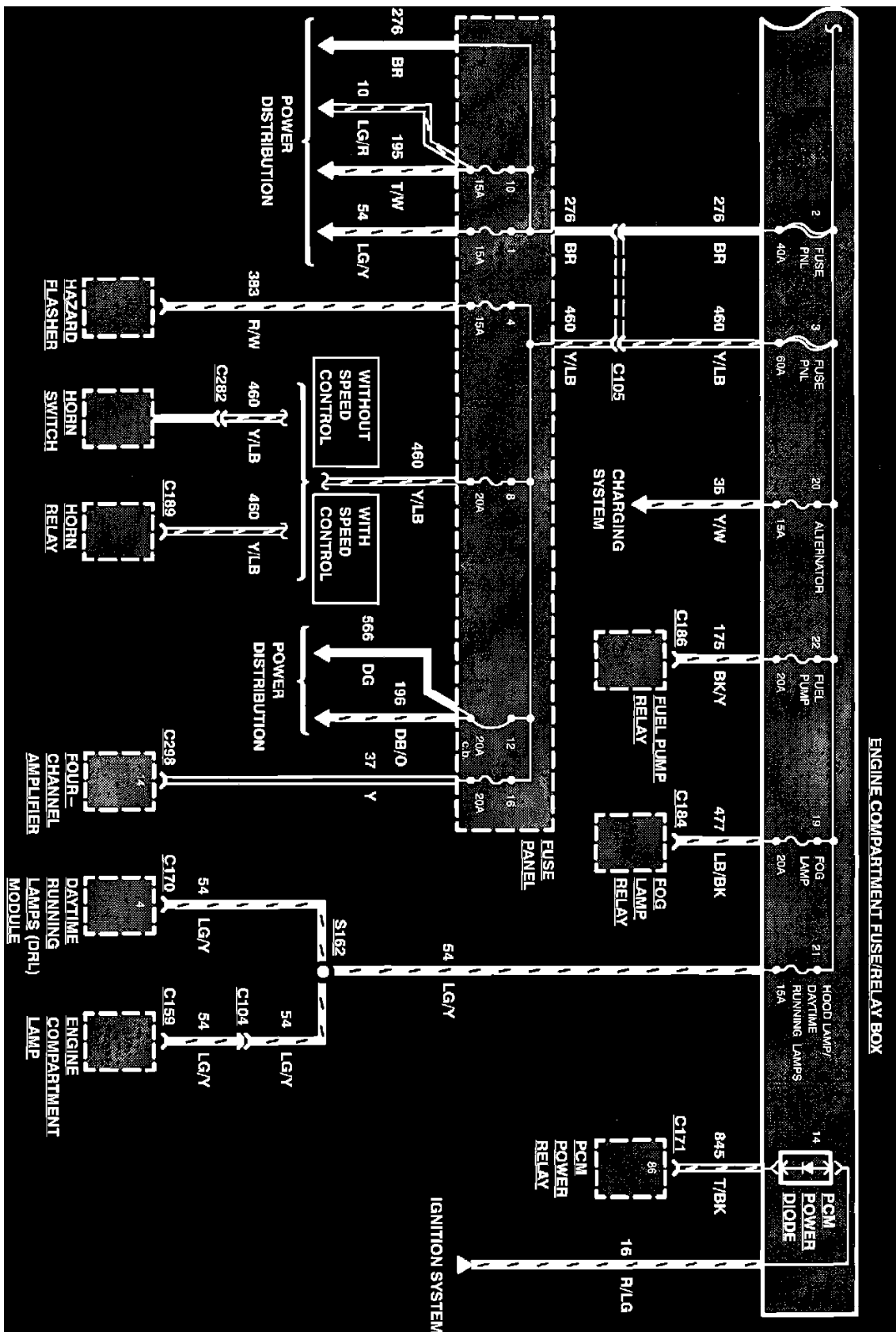

Power Distribution

Fuse HOOD LAMP/DAYTIME RUNNING LAMPS

Fuse HOOD LAMP/DAYTIME RUNNING LAMPS - protects the following circuits:

- Hood Lamp
- Daytime Running Lamp Module (2 of 2 Power Feeds)

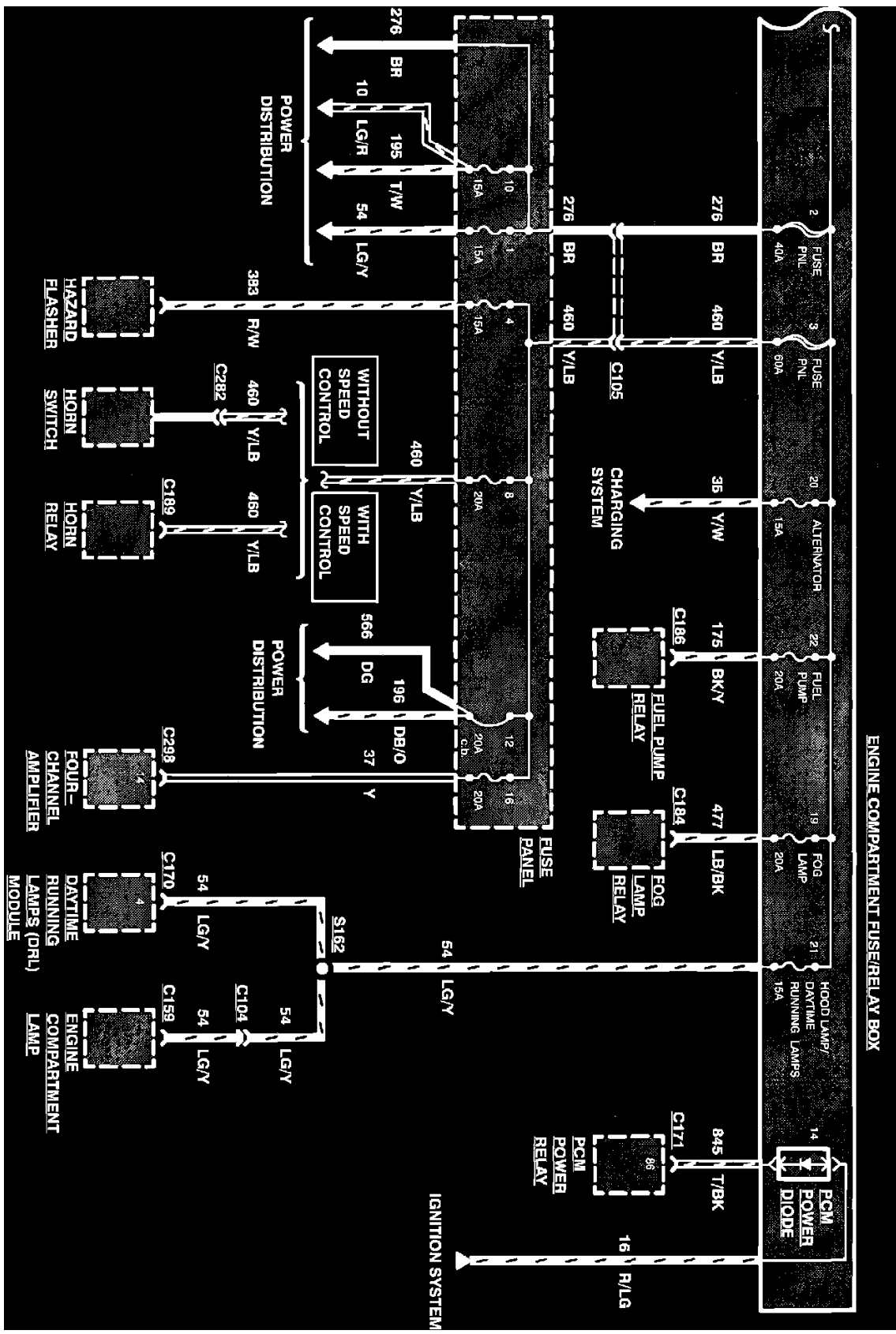

Power Distribution

Fuse IGN

Fuse IGN - protects the following circuit:
 - Ignition Switch

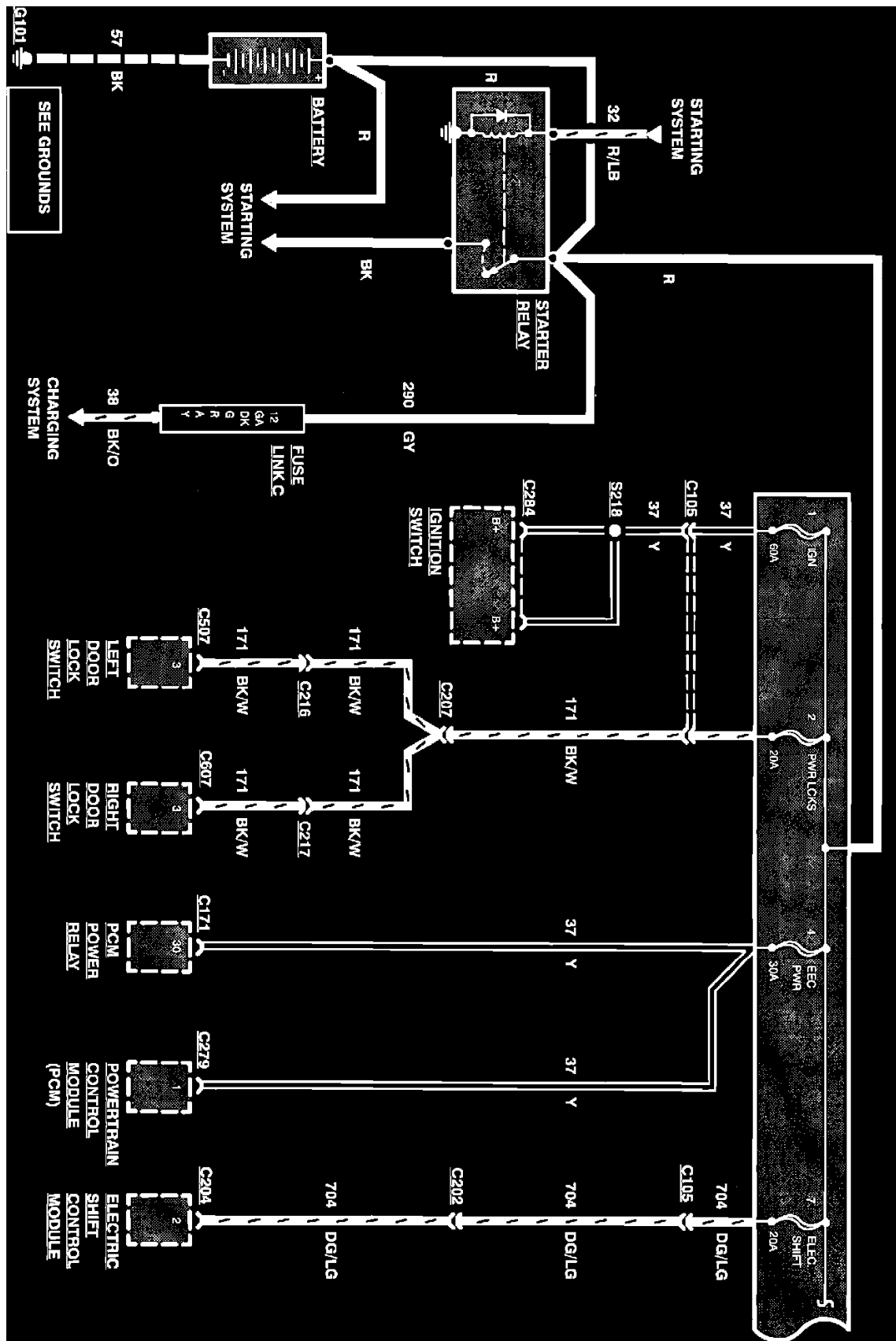

Power Distribution

Fuse PCM POWER DIODE

Fuse PCM POWER DIODE - protects the following circuit:
 - PCM Relay (2 of 2 Power Feeds from Ignition Switch)

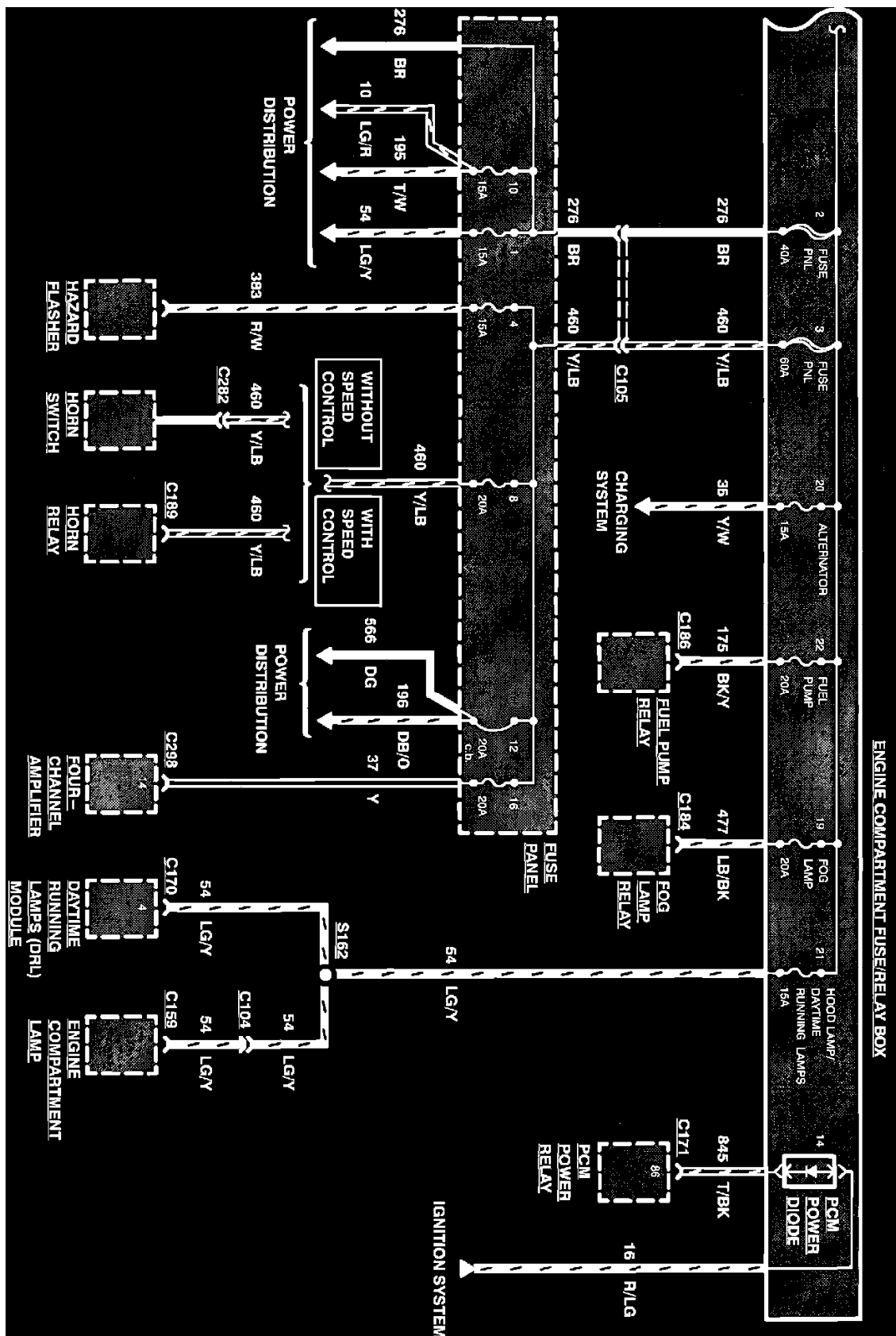

Power Distribution

Fuse PNL (60A Maxi)

Fuse PNL (60A Maxi) - protects the following circuits:

- Fuse 4 of Fuse Panel
- Fuse 8 of Fuse Panel
- Fuse 16 of Fuse Panel

- Circuit Breaker 12 of Fuse Panel

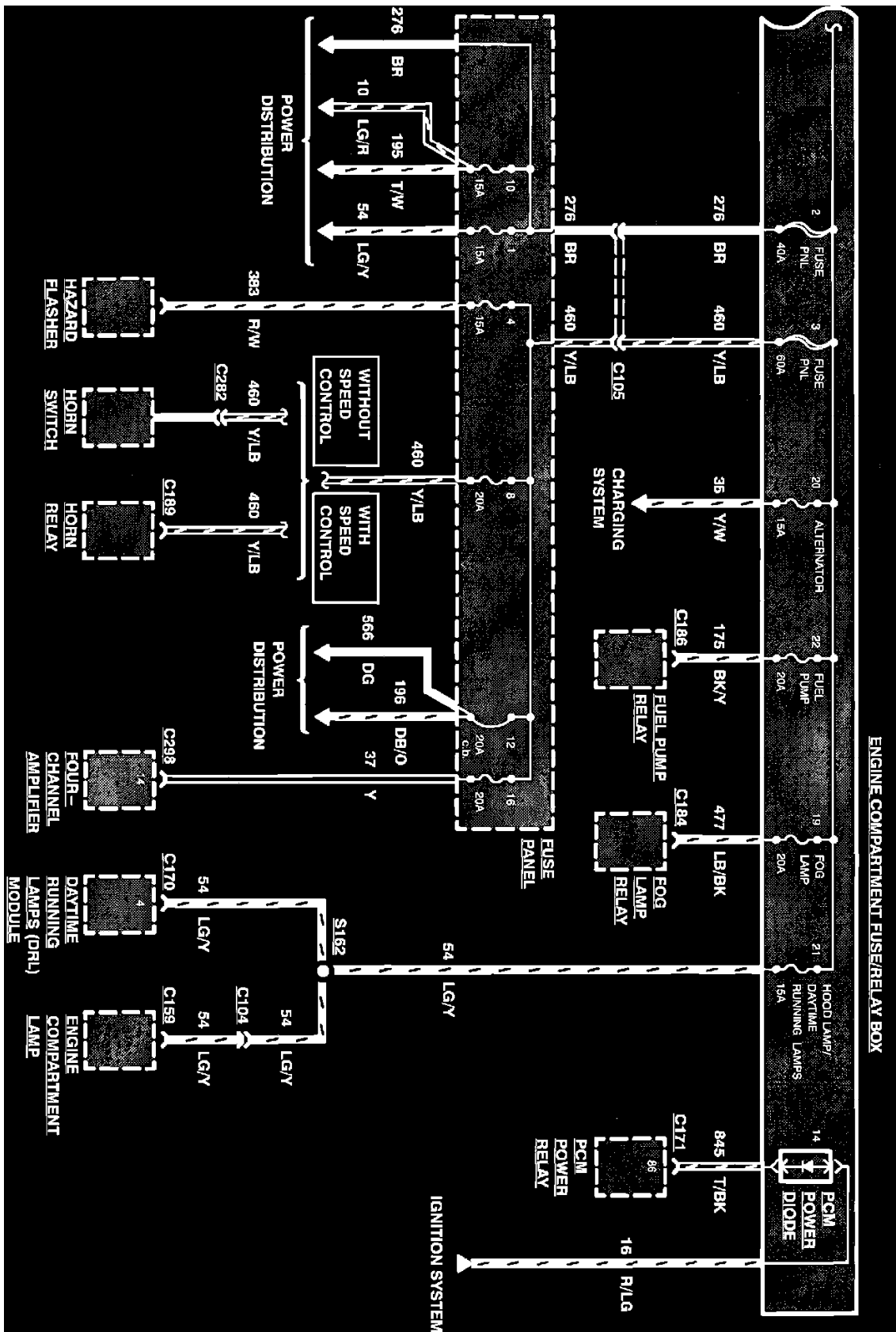

Power Distribution

Fuse PWR LCKS

Fuse PWR LCKS - protects the following circuits:

- Left Power Door Lock Switch
- Right Power Door Lock Switch

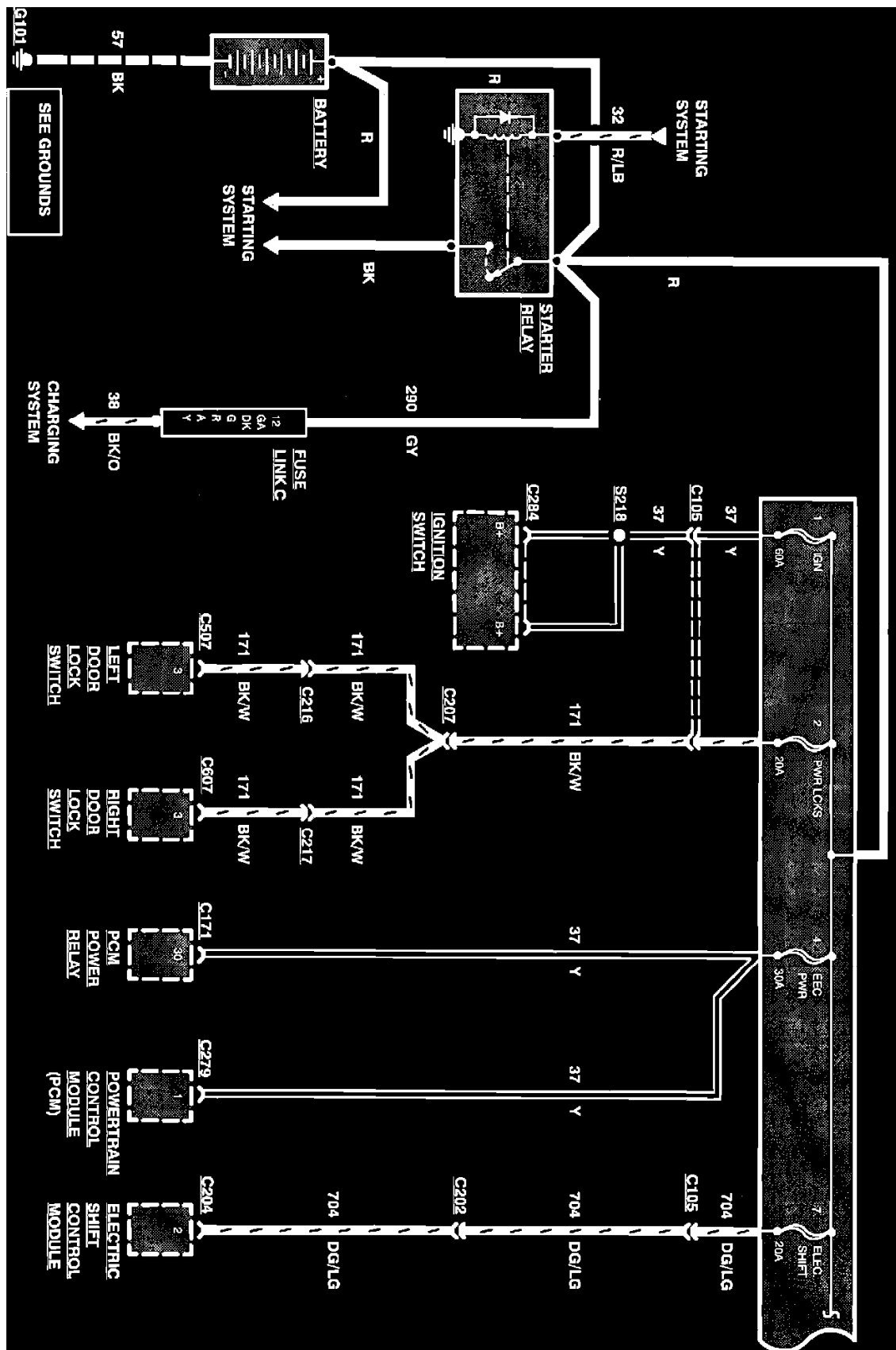

Power Distribution

Fuse Link Circuits

Fuse Link C - protects the following circuit:

- Integral Alternator/Regulator (2 of 2 Power Feeds)

